

Experimental study of an R1234ze/R134a mixture (R450A) as R134a replacement

Adrián Mota-Babiloni ^{a, b}, Joaquín Navarro-Esbrí ^{b, *}, Ángel Barragán-Cervera ^b,
Francisco Molés ^b, Bernardo Peris ^b

^a Institute for Industrial, Radiophysical and Environmental Safety, Camino de Vera s/n,
Polytechnic University of Valencia, E46022 Valencia, Spain.

^b ISTENER Research Group. Department of Mechanical Engineering and Construction,
Campus de Riu Sec s/n, University Jaume I, E12071, Castellón, Spain.

Abstract

This work presents an experimental analysis of a non-flammable R1234ze/R134a mixture (R450A) as R134a drop-in replacement. While R134a has a high GWP value (1430), the R450A GWP is only 547. The experimental tests are carried out in a vapour compression plant equipped with a variable-speed compressor. The replacement suitability has been studied combining different operating conditions: evaporation temperature, condensation temperature and the use of an internal heat exchanger (IHX). The drop-in cooling capacity of R450A compared with R134a is 6% lower as average. R450A COP is even higher to those resulting with R134a (approximately 1%). The discharge temperature of R450A is lower than that of R134a, 2K as average. The IHX has a similar positive influence on the energy performance of both fluids. In conclusion, R450A can be considered as a good candidate to replace R134a.

Keywords: refrigeration; R450A; R134a; mixture; energy efficiency; drop-in.

Nomenclature

Symbols

COP Coefficient of Performance

c_p Isobaric Heat Capacity ($\text{kJ kg}^{-1} \text{K}^{-1}$)

h enthalpy (kJ kg^{-1})

\dot{m}_{ref} refrigerant mass flow rate (kg s^{-1})

* Corresponding Author:

Tel: +34 964387529; fax: +34 964728106.

E-mail address: navarroj@uji.es

N	compressor rotation speed (rpm)
\dot{Q}_o	cooling capacity (kW)
T	temperature (K)
\dot{W}_c	compressor power consumption (kW)

Subscripts

disc discharge

in inlet

k condenser

o evaporator

out outlet

Abbreviations

GWP_{100-yr} Global Warming Potential calculated over 100 years

HFC Hydrofluorocarbon

HFO Hydrofluoroolefin

IHX Internal Heat Exchanger

ODP Ozone Depletion Potential

PID Proportional Integral Derivative

POE Polyolester

NBP Normal Boiling Point

TXV Thermostatic Expansion Valve

1. Introduction

Due to the environmental concern caused by the global warming, the European Union is taking regulatory action to limit the greenhouse gases emissions. The first F-gas Regulation (Directive 2006/40/EC) [1] was adopted in 2006 and it was addressed to mobile air conditioning systems, affecting refrigerants with $GWP_{100\text{-yr}}$ values (Global Warming Potential calculated over 100 years) above 150. Nowadays a new F-gas Regulation [2] is being approved. It starts in 2015 and extends the GWP limitations to the remaining refrigeration systems.

Diverse hydrofluoroolefin (HFO) fluids were proposed as low-flammable and low-GWP replacements to current high-GWP hydrofluorocarbon (HFC) refrigerants (R134a, R404A, R410A, etc.) [3]. For the time being, R1234yf and R1234ze(E) seem to be the most suitable commercial HFO alternatives [4]. For example, in automotive systems, the refrigerant R1234yf ($GWP=4$) has been imposed as R134a drop-in replacement [5]. Regarding another refrigeration systems, it has shown lower performance than R134a in a drop-in replacement [6].

The R1234ze(E) (henceforth it will be referred simply as R1234ze) is proposed as R32 (or R410A) and R134a replacement. It has $GWP=6$, zero-ODP, low toxicity [7] and, although it is classified as A2L by ASHRAE, it has been proved to be less flammable than R1234yf [8]. Its thermodynamic and thermophysical properties have been recently investigated in many studies (as those performed by Meng et al. [9] or Qiu et al. [10], exhibiting low uncertainty). In a drop-in analysis replacement for R134a performed by Mota-Babiloni et al. [11], R1234ze presented lower cooling capacity and COP than R134a, although COP improvements can be found in optimized chillers. Besides, R1234ze flow boiling local heat transfer coefficients are very similar to those of R134a [12] and lower to those of R32 [13]. About condensation, it was found that the heat transfer performance of R1234ze was lower than R134a (but higher than R1234yf) [14] and lower than R32 (but higher than R410A) [15].

R1234ze has been also widely studied in heat pump and air conditioning systems. Fukuda et al. [16] demonstrated in a heat pump simulation that R1234ze is a potential alternative in high-temperature heat pump systems for industrial purposes. Otherwise, R1234ze has shown a slightly higher performance than R134a in a based adsorption cooling cycle for different heating and cooling water inlet temperatures [17].

In order to overcome limitations related to HFOs (as flammability [18] or minor cooling capacity [19]), it has been developed several mixtures of HFO with HFCs [20] or even natural refrigerants [21]. In the concrete case of the R1234ze, it has been studied mixed with R152a [22], R134a [23] or R32 [24].

In response to the need of implement low-GWP fluids in the refrigeration systems (pure and mixture refrigerants), the Air-Conditioning, Heating, and Refrigeration Institute (AHRI) began a collaborative investigation (with the support of various research groups) to study the behaviour of the new fluorinated refrigerants [25]. Thus, Schultz and Kujak

[26] found, in a water-cooled chiller installation, that R450A (previously known as Solstice™ N13) [27] is a promising candidate to replace R134a. In another study developed by Mota-Babiloni et al. [28], two R1234ze mixtures also presented good energy efficiency results compared with R404A.

As R1234ze is not recommended as R134a drop-in replacement in refrigeration systems, in this work an energetic analysis of a commercial R1234ze/R134a mixture (R450A) as R134a drop-in alternative in a vapour compression plant has been performed. To address the comparison, several experimental tests are carried out varying different parameters obtaining a wide range of operation. The following parameters are analysed: cooling capacity, COP and also discharge temperature.

The rest of the paper is organized as follows: In section 2, the experimental setup is shown. In section 3, the test conditions and the fluids used in this analysis are presented. In section 4, the experimental results are exposed and discussed. Finally, in section 5, the main conclusions of the paper are summarized.

2. Experimental setup

The experimental tests are carried out in a fully monitored vapour compression plant, which schematic diagram is shown in Figure 1. The test bench consist of a main circuit (refrigerating circuit) and two secondary circuits (heat removal and heat load circuits).

Figure 1. Test bench schematic diagram.

The main circuit components are the following:

- Reciprocating open piston compressor, driven by a variable-speed 5 kW electric motor. The compressor speed can be selected using an inverter.
- Shell-and-tube condenser (1-2), with refrigerant flowing along the shell and the water (used as secondary fluid) inside the tubes.
- Shell-and-tube evaporator (1-2), where the refrigerant flows inside the tubes and a water/propylene glycol mixture (65/35 by volume percentage) (used as secondary fluid flowing) along the shell.
- Thermal expansion valve.
- Counter flow tube-in-tube internal heat exchanger (IHx, also known as suction-liquid heat exchanger), which is activated or deactivated by a set of solenoid valves.

The secondary circuits allow varying the evaporation and condensation conditions. The heat load circuit is composed by a set of immersed electrical resistances regulated by a

Proportional Integral Derivative (PID) controller and the heat removal circuit uses a fan. In both circuits the flow rate can be adjusted using a variable-speed pump.

In order to display and storage the most relevant parameters of each experimental test a set of sensors and measurement devices are installed in the circuits. The location of the sensors can be seen in Figure 1 and a summary of the devices (containing the sensor type used and the uncertainty) in Table 1. Finally, all the signals generated by the sensors are gathered through a data acquisition system and monitored. The refrigerant thermodynamic states are based on data determined from REFPROP v9.1 [29].

Table 1. Summary of measured parameters, type of equipment installed and their uncertainty associated.

3. Experimental procedure

3.1 Fluids selected.

As exposed before, R134a and a mixture of R1234ze and R134a (58/42 in mass percentage, registered as R450A) are the working fluids used in this work. In Table 2 the main properties of these three fluids are shown to check the properties similarity between this fluid and R134a.

Table 2. Main characteristics of the fluids selected.

R450A and R134a present similar properties: R450A densities (higher suction volumetric flow rate), heat capacities and liquid viscosity are slightly lower than those of R134a whereas vapour viscosity is slightly higher. Liquid thermal conductivity is 10% lower for R450A and that obtained for vapour is almost the same.

It should be highlighted the GWP reduction achieved using the replacement (R450A GWP is 547 while R134a GWP is 1430). Another important fact is that if R1234ze and R134a are mixed in this composition, a non-flammable refrigerant is originated. Moreover, R450A is a near azeotrope mixture (at 0.1MPa its glide is around 0.8K, similar to that presented by R404A). These characteristics make R450A a good option as R134a alternative in chillers, heat pumps, cascade and mid-temperature refrigeration systems either in direct expansion or flooded architectures.

3.2 Test set conditions.

The target of the tests is to span the most complete range of conditions in R134a refrigeration systems. Thus, the test conditions are as follows:

- Evaporation temperature: 260K/270K/280K (medium evaporation temperature).
- Condensation temperature: 300K/310K/320K/330K (covering winter, summer and intermediate conditions).
- IHX activation: OFF/ON.
- The superheating degree is fixed by the TXV in 7K (± 1 K variation).
- The lubricant used for all refrigerants was a Polyolester (POE) lubricant.
- The R450A refrigerant charge was approximately 3% than that for R134a.

It should be noted that the test at $T_o=263$ K and $T_k=300$ K can't be realized due to experimental setup limitations.

4. Experimental results

In this section, the main results of the comparison between R134a and R450A are presented. The work is performed without making any changes at the installation (except a thermal expansion valve adjustment to maintain the superheating degree). The parameters studied are cooling capacity, COP and discharge temperature.

The cooling capacity (\dot{Q}_o) is obtained as the product of the refrigerant mass flow rate (\dot{m}_{ref}) and the enthalpy increase at the evaporator, Eq. (1).

$$\dot{Q}_o = \dot{m}_{ref} (h_{out} - h_{in})_o \quad (1)$$

Finally, the COP is calculated dividing the cooling capacity and the compressor power consumption (\dot{W}_C , that it is measured directly using a digital wattmeter), Eq. (2).

$$COP = \frac{\dot{Q}_o}{\dot{W}_C} \quad (2)$$

The cooling capacity and COP uncertainties are calculated using the Root Sum Square (RSS) method [30] and they are summarized in Table 3 (see Table 1 for discharge temperature uncertainty).

Table 3. Summary of the main results uncertainty.

Besides, the energetic results (\dot{Q}_o and COP) are exposed as relative deviation taking R134a as baseline, Eq. (3) and (4). For cooling capacity deviation absolute value is used since the corresponding values become always negative (cooling capacity reduction).

$$|\% \dot{Q}_o| = \left| \frac{\dot{Q}_{oR450A} - \dot{Q}_{oR134a}}{\dot{Q}_{oR134a}} \right| \cdot 100 \quad (3)$$

$$\%COP = \left(\frac{COP_{R450A} - COP_{R134a}}{COP_{R134a}} \right) \cdot 100 \quad (4)$$

4.1 Cooling capacity

As a result of lower R450A mass flow rate and similar evaporator enthalpy difference, R134a the values obtained for the cooling capacity using R134a are slightly higher than those obtained using R450A. Figure 2 shows the cooling capacity reduction obtained using R450 as R134a drop-in replacement (Eq. (3)) at different evaporation and condensation temperatures, with and without IHX.

Figure 2. Cooling capacity relative reduction taking R134a as baseline a) with IHX and b) without IHX.

The difference between both refrigerants becomes higher when the compression ratio grows (this trend agrees to theoretical results). In other words, the R450A cooling capacity becomes lower than that obtained using R134a at lower evaporation temperature and higher condensation temperature.

Analysing the results when the IHX is deactivated (Figure 2.a), the R450A cooling capacity reduction compared with R134a goes from 8% to 6% at low evaporation temperature (260K) and from 7% to 4% at high evaporation temperature (280K). When the IHX is used, Figure 2.b, the cooling capacity reduction using R450A is attenuated about 1% as average. That means that the IHX produces a greater benefit on R450A than R134a (it is well known that it is a positive effect due to the evaporator enthalpy difference increase). Thus, the cooling capacity reduction with IHX goes from 6% to 5% at $T_o=260K$ and from 6% to 4% at $T_o=280K$.

4.2 Coefficient of Performance

The COP deviation using R450A as drop-in replacement for R134a is reported in Figure 3. As it happened with the cooling capacity, the higher the evaporation temperature and the lower the condensing temperature, the smaller is the COP difference between both refrigerants. As far as the comparison among the different refrigerants is concerned, it can be noted that the R450A COP obtained is similar (or even higher) than those obtained using R134a.

Figure 3. R450A COP relative increase taking R134a as baseline a) with IHX and b) without IHX.

Considering the test performed without IHX (Figure 3.a) the larger R450A COP relative increase taking R134a as baseline is obtained at high evaporation temperatures. Thus, R450A COP relative increases varies from a minimum of 0.2% to a maximum of 1.3% for low evaporation temperature and goes from 0.4% to 2% for high evaporation temperatures. In figure 2, at 260K, due to the low values of COP, the measurement uncertainties can cause irregular trends.

The COP average differences between both refrigerants continue being similar when the IHX is activated, being no significant differences in R450A COP relative increases when the IHX is activated.

According to R450A COP results and contrary to that obtained with R1234ze (R1234ze COP is about 6% lower than that obtained using R134a) [10], it can be concluded that using this blend as R134a alternative will imply a lower energy consumption considering the same cooling capacity necessities, which would be reflected in a decrease in the environmental impact derived from indirect emissions.

4.3 Compressor discharge temperature

Finally, Figure 4 shows the discharge temperature differences between R134a and R450. It is observed that the R450A discharge temperatures are slightly lower than those obtained using R134a. The difference becomes higher at high compression ratios and when the IHX is activated. In the highest compression ratio test, the difference between R450A and R134a discharge temperatures is minor, being approximately 2K and 3K as average and 3.5K and 5K as maximum, with and without IHX, respectively. R450A discharge temperatures do not reach values that can affect the compressor.

Figure 4. Discharge temperature differences between R134a and R450A a) without IHX and b) with IHX.

Mixing R1234ze and R134a in similar proportions reduces a little the discharge temperature (using pure R1234ze the effect is more notable).

5. Conclusions

In this study, the R450A performance as R134a drop-in replacement was analysed in a vapour compression system under a wide range of operating conditions. The parameters analysed were cooling capacity, coefficient of performance and discharge temperature. The main conclusions of the paper are summarized below.

The R450A drop-in cooling capacity is slightly lower than those obtained with R134a (6% lower as average). The compressor power consumption is much lower using

R450A than R134a, so the R450A COP rises until being 1% higher than R134a as average. The IHX affects positively to the R450A energy efficiency, in a similar proportion that influences on R134a.

The discharge temperature of the alternative is lower than that of R134a, 2K as average. For the highest compression ratio considered in this work, R450A discharge temperature is 4.3K lower (). Considering also the lower condensation pressures for R450A (around 1bar less than R134a), allows enlarged operating limits and optimized compressors would face less mechanical losses and hence a higher COP.

Although it is found that can be used directly R450A in R134a systems with good performance (slightly lower cooling capacity and similar COP), it is advisable to redesign and optimize it in order to obtain better performance that would derive in better energy performance and hence, lower power consumption.

R450A is a non-flammable refrigerant (contrary to R1234ze and R1234yf) and it can be used as safe working fluid in systems where fluids with $GWP < 1500$ are allowed according to present and future regulations. Also it should be considered the lower R450A discharge temperature, lower pressure and higher critical temperature.

Acknowledgements

The authors thankfully acknowledge “Ministerio de Educación, Cultura y Deporte” for supporting this work through “Becas y Contratos de Formación de Profesorado Universitario del Programa Nacional de Formación de Recursos Humanos de Investigación del ejercicio 2012”.

References

- [1] Directive 2006/40/EC of The European Parliament and of the Council of 17 May 2006 relating to emissions from air conditioning systems in motor vehicles and amending Council Directive 70/156/EC. Official Journal of the European Union (2006).
- [2] Regulation (EU) No 517/2014 of the European Parliament and the Council of 16 April 2014 on fluorinated greenhouse gases and repealing Regulation (EC) No 842/2006. Official Journal of the European Union (2014).
- [3] J.M. Calm. The next generation of refrigerants – Historical review, considerations, and outlook. *International Journal of Refrigeration* 31 (2008), 1123-1133.
- [4] M.O. McLinden, A.F. Kazakov, J.S. Brown, P.A. Domanski. A thermodynamic analysis of refrigerants: Possibilities and tradeoffs for Low-GWP refrigerants. *International Journal of Refrigeration* 38 (2014) 80-92.
- [5] B. Minor, M.A. Spatz. HFO-1234yf: a low GWP refrigerant for MAC. VDA Alternative Refrigerant Winter Meeting, Saalfelden, Salzburg, Austria, 13-14 February 2008.

- [6] J. Navarro-Esbrí, J.M. Mendoza-Miranda, A. Mota-Babiloni, A. Barragán-Cervera, J.M. Belman-Flores. Experimental analysis of R1234yf as a drop-in replacement for R134a in a vapor compression system. *International Journal of Refrigeration* 36 (2013) 870-880.
- [7] P. Schuster, R. Bertermann, G.M. Rusch, W. Dekant. Biotransformation of trans-1,1,1,3-tetrafluoropropene (HFO-1234ze). *Toxicology and Applied Pharmacology* 239 (2009) 215-223.
- [8] S. Kondo, K. Takizawa, K. Tokuhashi. Effects of temperature and humidity on the flammability limits of several 2L refrigerants. *Journal of Fluorine Chemistry* 144 (2012) 130-136.
- [9] X. Meng, G. Qiu, J. Wu, I.M. Abdulagatov. Viscosity measurements for 2,3,3,3-tetrafluoroprop-1-ene (R1234yf) and trans-1,3,3,3-tetrafluoropropene (R1234ze(E)). *The Journal of Chemical Thermodynamics* 63 (2013) 24-30.
- [10] G. Qiu, X. Meng, J. Wu. Density measurements for 2,3,3,3-tetrafluoroprop-1-ene (R1234yf) and trans-1,3,3,3-tetrafluoropropene (R1234ze(E)). *The Journal of Chemical Thermodynamics* 60 (2013) 150-158.
- [11] A. Mota-Babiloni, J. Navarro-Esbrí, Á Barragán, F. Molés, B. Peris. Drop-in energy performance evaluation of R1234yf and R1234ze(E) in a vapour compression system as R134a replacements. *Applied Thermal Engineering* 71 (2014) 259-265.
- [12] S. Grauso, R. Mastrullo, A.W. Mauro, J.R. Thome, G.P. Vanoli. Flow pattern map, heat transfer and pressure drops during evaporation of R-1234ze(E) and R134a in a horizontal, circular smooth tube: Experiments and assessment of predictive methods. *International Journal of Refrigeration* 36 (2013) 478-491.
- [13] C. Kondou, D. BaBa, F. Mishima, S. Koyama. Flow boiling of non-azeotropic mixture R32/R1234ze(E) in horizontal microfin tubes. *International Journal of Refrigeration* 36 (2013) 2366-2378.
- [14] G.A. Longo, C. Zilio, G. Righetti, J. S. Brown. Condensation of the low GWP refrigerant HFO1234ze(E) inside a Brazed Plate Heat Exchanger. *International Journal of Refrigeration* 38 (2014) 250-259.
- [15] Md.A. Hossain, Y. Onaka, A. Miyara. Experimental study on condensation heat transfer and pressure drop in horizontal smooth tube for R1234ze(E), R32 and R410A. *International Journal of Refrigeration* 35 (2012) 927-93.
- [16] S. Fukuda, C. Kondou, N. Takata, S. Koyama. Low GWP refrigerants R1234ze(E) and R1234ze(Z) for high temperature heat pumps. *International Journal of Refrigeration* 40 (2013) 161-173.
- [17] S. Jribi, B.B. Saha, S. Koyama, A. Chakraborty, K.C. Ng. Study on activated carbon/HFO-1234ze(E) based adsorption cooling cycle. *Applied Thermal Engineering* 50 (2013) 1570-1575.
- [18] Y. Lee, D.G. Kang, D. Jung. Performance of virtually non-flammable azeotropic HFO1234yf/HFC134a mixture for HFC134a applications. *International Journal of Refrigeration* 36 (2013) 1203-1207.

- [19] D. Leighton, Y. Hwang, R. Radermacher. Modeling of Household Refrigerator Performance with Low Global Warming Potential Alternative Refrigerants. *ASHRAE Transactions* 118 (2012) 658-665.
- [20] T. Kamiaka, C. Dang, E. Hihara. Vapor-liquid equilibrium measurements for binary mixtures of R1234yf with R32, R125, and R134a. *International Journal of Refrigeration* 36 (2013) 965-971.
- [21] S. Kondo, K. Takizawa, K. Tokuhashi. Flammability limits of binary mixtures of ammonia with HFO-1234yf, HFO-1234ze, HFC-134a, and HFC-125. *Journal of Fluorine Chemistry* 149 (2013) 18-23.
- [22] Z. Yang, M. Gong, H. Guo, X. Dong, J. Wu. Phase equilibrium for the binary mixture of {1,1-difluoroethane (R152a+ trans-1,3,3,3-tetrafluoropropene (R1234ze (E)))} at various temperatures from 258.150 to 288.150 K. *Fluid Phase Equilibria* 355 (2013) 99-103.
- [23] X. Dong, H. Guo, M. Gong, Z. Yang, J. Wu. Measurements of isothermal (vapour + liquid) equilibria data for {1,1,2,2-Tetrafluoroethane (R134a) + trans-1,3,3,3-tetrafluoropropene (R1234ze(E))} at T=(258.150 to 288.150)K. *The Journal of Chemical Thermodynamics* 60 (2013) 25-28.
- [24] R. Akasaka. Thermodynamic property models for the difluoromethane (R-32) + trans-1,3,3,3-tetrafluoropropene (R-1234ze(E)) and difluoromethane + 2,3,3,3-tetrafluoropropene (R-1234yf) mixtures. *Fluid Phase Equilibria* 358 (2013) 98-104.
- [25] X. Wang, K. Amrane, P. Johnson, Low Global Warming Potential (GWP) Alternative Refrigerants Evaluation Program (Low-GWP AREP), International Refrigeration and Air Conditioning Conference, Purdue, EEUU, 16-19 Julio, 2012.
- [26] K. Schultz, S. Kujak. Low GWP AREP R134a W/C Screw Chiller Test Summary – Final Report (2013). Retrieved online at: http://www.ahrinet.org/App_Content/ahri/files/RESEARCH/AREP_Final_Reports/AHRI%20Low-GWP%20AREP-Rpt-007.pdf, 5 June 2014.
- [27] Honeywell. Solstice family of HFOs (2013). Retrieved online at: <http://www.racplus.com/Journals/2012/06/01/g/s/r/Honeywell-presentation.pdf>, 5 June 2014.
- [28] A. Mota-Babiloni, J. Navarro-Esbrí, Á. Barragán, F. Molés, B. Peris. Theoretical comparison of low GWP alternatives for different refrigeration configurations taking R404A as baseline, *International Journal of Refrigeration* 44 (2014) 81-90.
- [29] E.W. Lemmon, M.L. Huber, M.O. McLinden, REFPROP, NIST Standard Reference Database 23, v.9.1, National Institute of Standards, Gaithersburg, MD, USA, 2014.
- [30] J.R. Taylor. *An Introduction to Error Analysis*, 2nd ed. University Science Books, Sausalito, 1997.

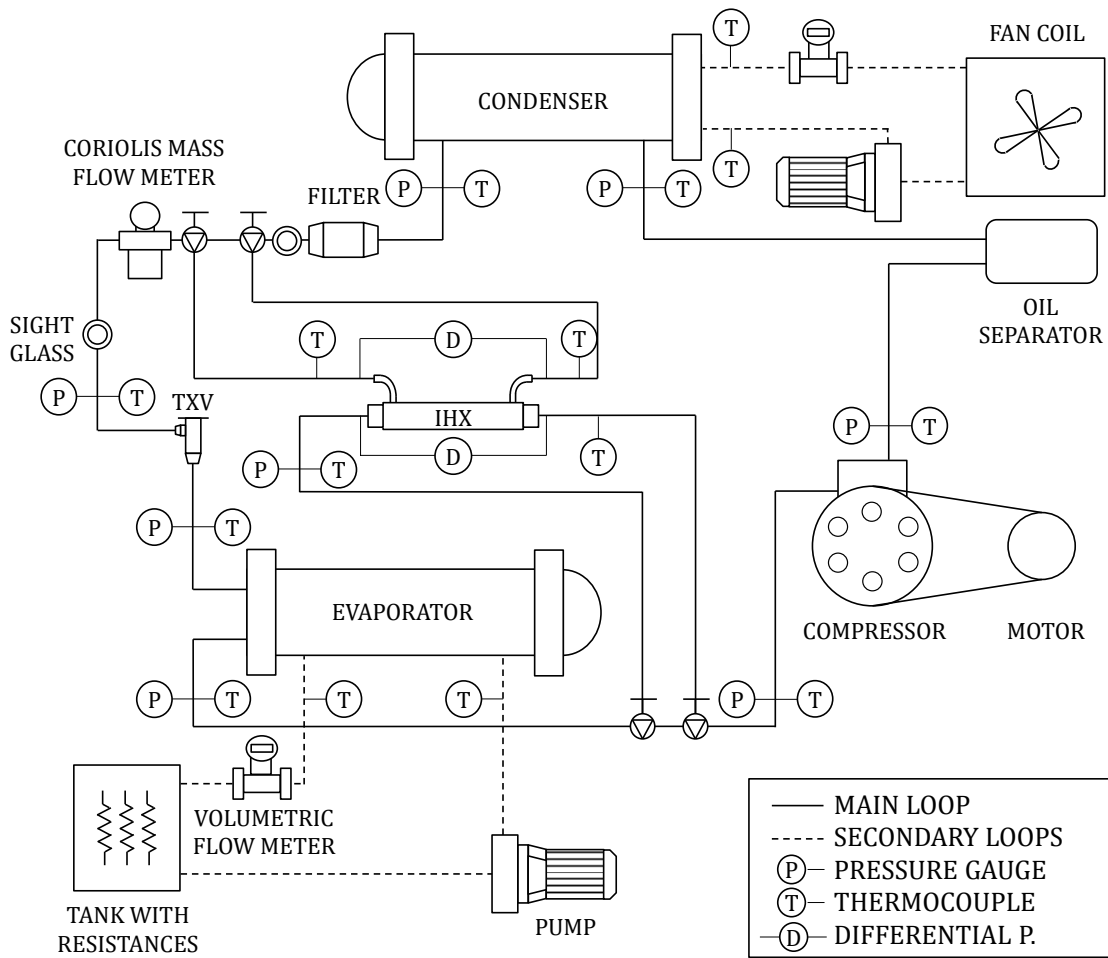
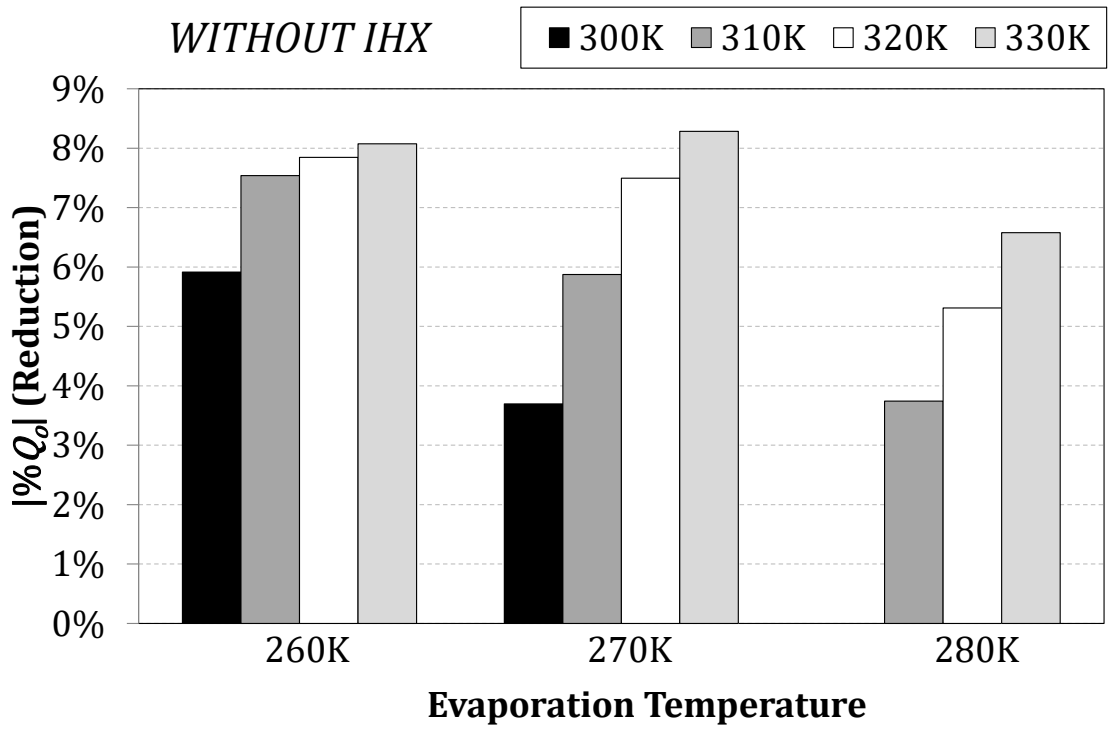
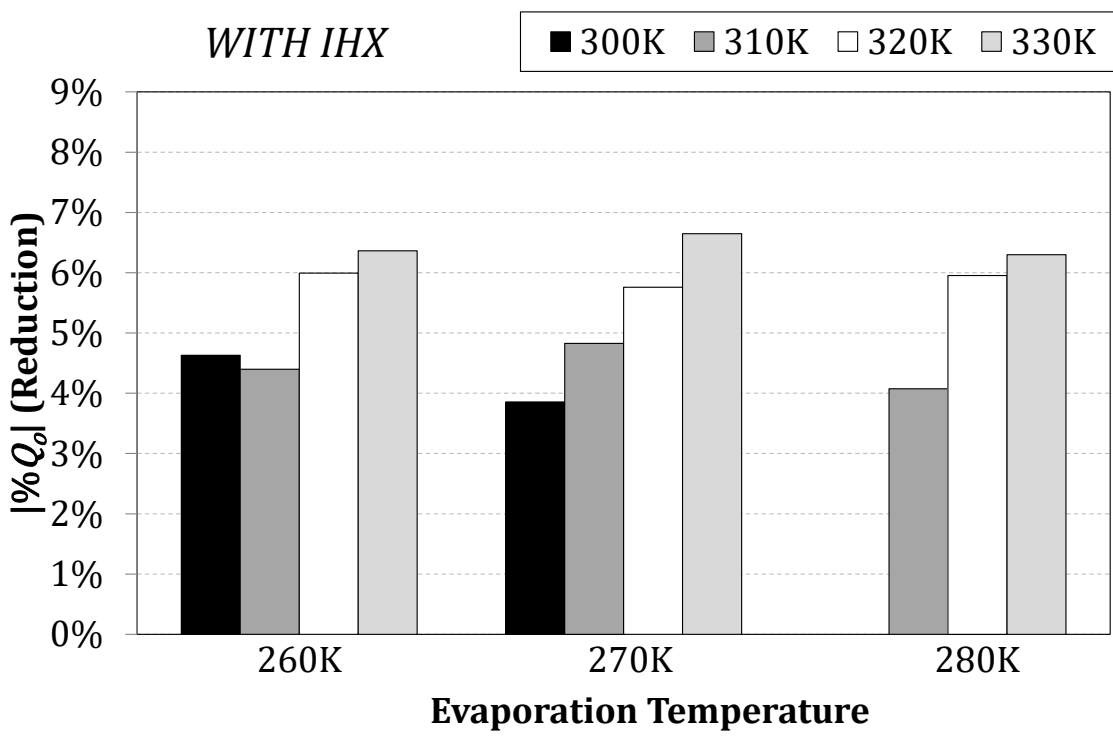

Figure 1. Test bench schematic diagram.



a)



b)

Figure 2. Cooling capacity relative reduction taking R134a as baseline a) with IHX and b) without IHX.

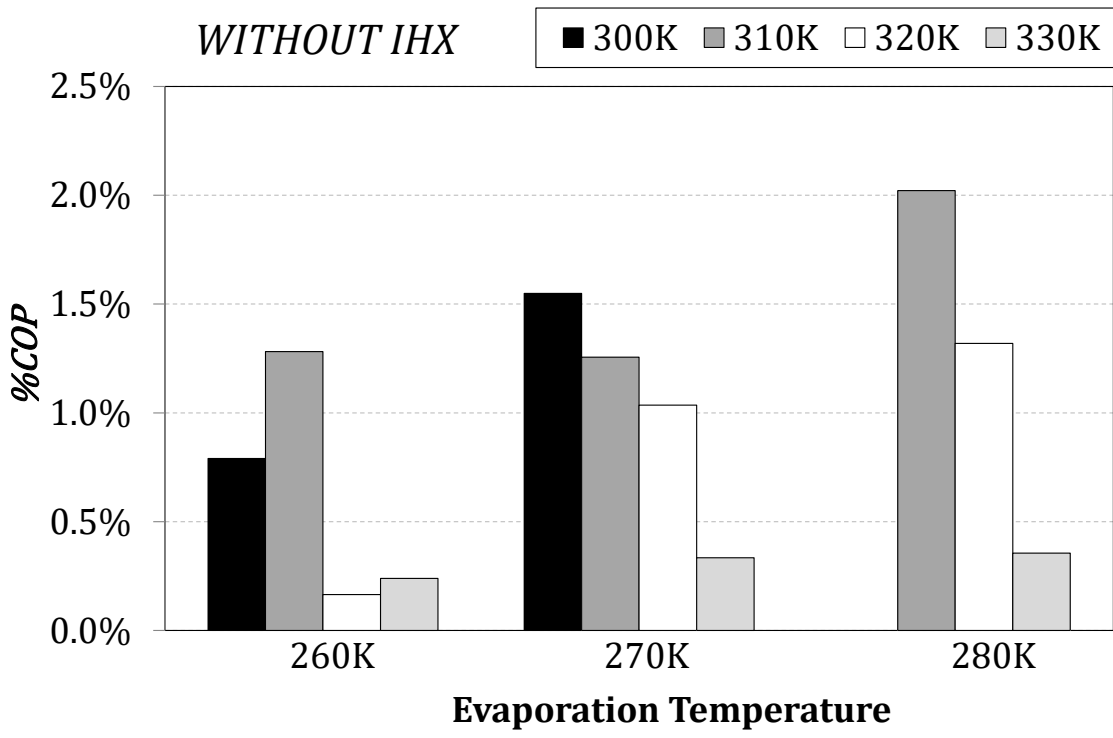

a)

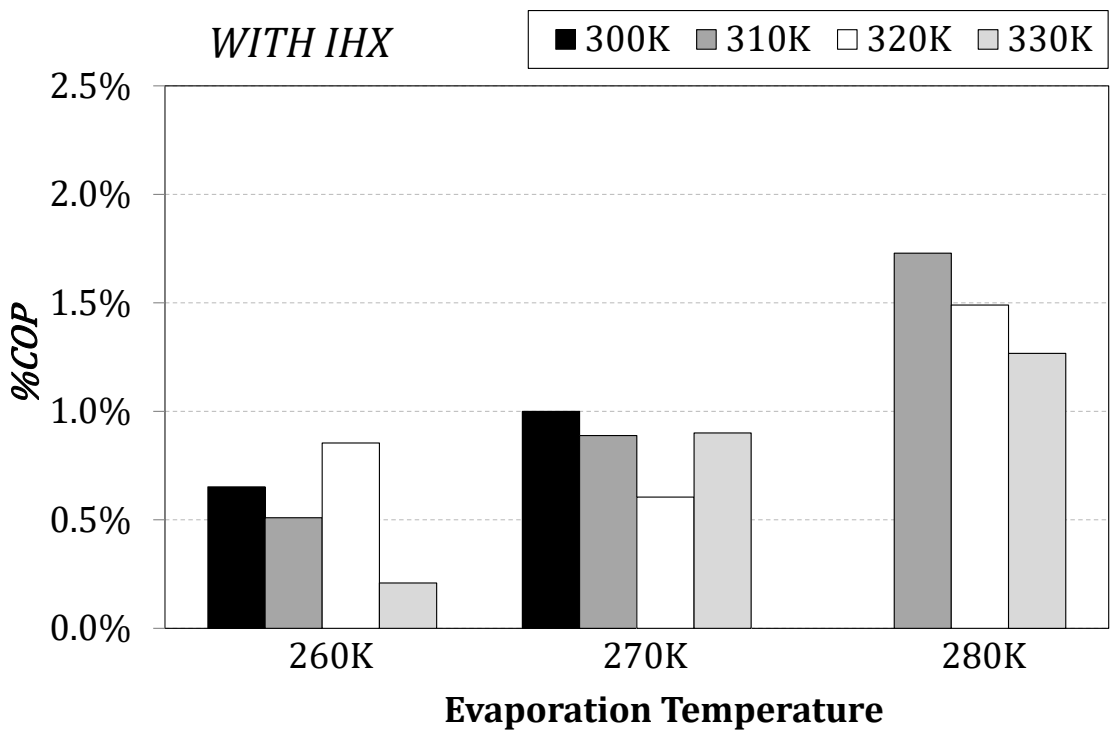

b)

Figure 3. R450 COP relative increase taking R134a as baseline a) with IHX and b) without IHX.

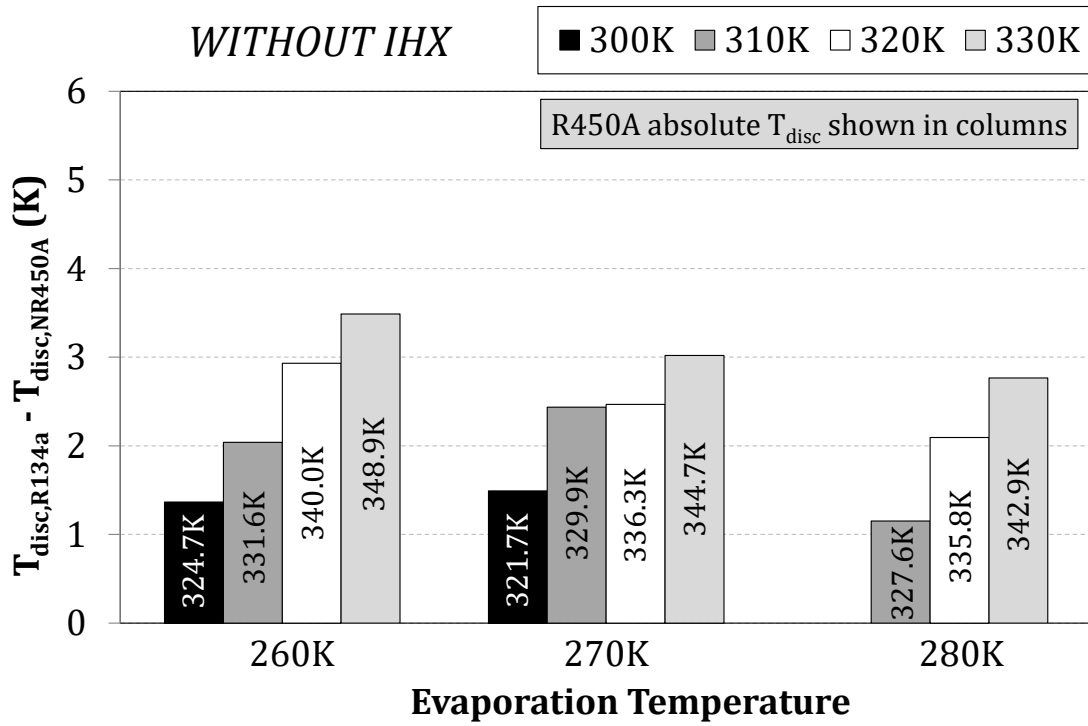

a)

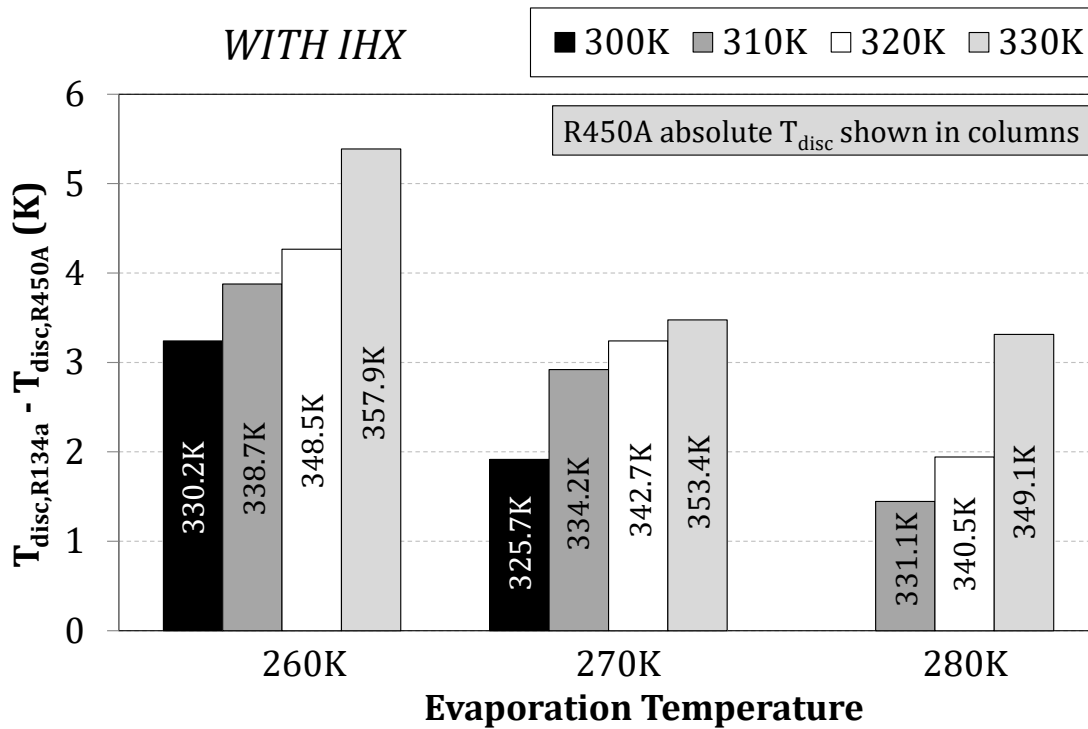

b)

Figure 4. Discharge temperature differences between R134a and R450A a) without IHX and b) with IHX.

Figure Captions

Figure 1. Test bench schematic diagram.

Figure 2. Cooling capacity relative reduction taking R134a as baseline a) with IHX and b) without IHX.

Figure 3. COP relative deviation taking R134a as baseline a) with IHX and b) without IHX.

Figure 4. Discharge temperature differences between R134a and R450A a) without IHX and b) with IHX.

Table 1. Summary of measured parameters, type of equipment installed and their uncertainty associated.

Measured parameters	Sensor installed	Uncertainty
Temperatures	K-type thermocouples	$\pm 0.3\text{K}$
Pressures	Piezoelectric pressure transducers	$\pm 7\text{kPa}$
Mass flow rate	Coriolis mass flow meter	$\pm 0.22\%$
Compressor power consumption	Digital wattmeter	$\pm 0.15\%$
Compressor rotation speed	Capacitive sensor	$\pm 1\%$
Pressure drops in the IHX	Differential pressure transducers	$\pm 0.01\text{kPa}$

Table 2. Main characteristics of refrigerants studied.

	R134a	R450A <i>58%R1234ze / 42%R134a</i>
ASHRAE		
safety classification	A1	A1
ODP	0	0
100-year GWP	1430	547
Critical Temperature (K)	374.21	379.02
Critical Pressure (kPa)	4059	3814
NBP (K)	247.08	251.20
Liquid density ^a (kg m⁻³)	1295.27	1253.28
Vapor density ^a (kg m⁻³)	14.35	13.93
Liquid c_p ^a (kJ kg⁻¹ K⁻¹)	1.34	1.32
Vapor c_p ^a (kJ kg⁻¹ K⁻¹)	0.90	0.89
Liquid therm. cond. ^a (W/m-K)	$92.08 \cdot 10^{-3}$	$83.09 \cdot 10^{-3}$
Vapor therm. cond. ^a (W m⁻¹ K⁻¹)	$11.50 \cdot 10^{-3}$	$11.57 \cdot 10^{-3}$
Liquid viscosity ^a (Pa s⁻¹)	$267.04 \cdot 10^{-6}$	$258.22 \cdot 10^{-6}$
Vapor viscosity ^a (Pa s⁻¹)	$10.72 \cdot 10^{-6}$	$11.15 \cdot 10^{-6}$

^a at 273K.

Table 3. Summary of the main results uncertainty.

	T_o (K)	T_k (K)	\dot{Q}_o	COP
R134a	260	300	0.682%	0.832%
	260	310	0.741%	0.891%
	260	320	0.804%	0.954%
	260	330	0.878%	1.028%
	270	300	0.689%	0.839%
	270	310	0.697%	0.847%
	270	320	0.778%	0.928%
	270	330	0.857%	1.007%
	280	310	0.694%	0.844%
	280	320	0.722%	0.872%
280	330	0.813%	0.963%	
R450A	260	300	0.698%	0.848%
	260	310	0.765%	0.915%
	260	320	0.835%	0.985%
	260	330	0.922%	1.072%
	270	300	0.691%	0.841%
	270	310	0.730%	0.880%
	270	320	0.817%	0.967%
	270	330	0.908%	1.058%
	280	310	0.723%	0.873%
	280	320	0.788%	0.938%
280	330	0.880%	1.030%	