

**Bracelet with pulsometer and float that allows the users
ascend to the surface of the water.**

Author: **Lluís Peris Miralles**
Academic tutor: Octavio Bernad Ros
Industrial Design and Product Development Engineering
October 2019

1. REPORT.

1.1. Object.....	12
1.2. Scope.....	12
1.3. Precedents.....	13
1.4. Standards and references	14
1.4.1. Legal provisions and applied norms/standards:	14
1.4.2. Bibliography	16
1.4.3. Informatic programs	18
1.4.4. Definitions and abbreviations	19
1.5. Design requirement.....	20
1.5.1 Problem definition.....	20
1.6. Objective definition.....	20
1.6.1 Circumstances around the design	20
1.6.2 Available resources	21
1.6.3 User profile	21
1.6.4 Objectives to follow	22
1.6.5 Analysis of the objectives	23
1.6.6 Specifications and restrictions	25
1.7. Analysis of solutions.....	28
1.7.1. Sketches and alternatives	28
1.7.2. Study of the alternatives	33
1.8. Final results.....	36
1.8.1. General description of the product	36
1.8.2. Detailed description of the product	37
1.8.2.1 The neoprene suit	37
1.8.2.2 Joining method	39
1.8.2.3 The float	39
1.8.2.4 Harness or sealed	40

1.8.2.5 Back pocket and CCS	41
1.8.2.6 The valve	45
1.8.2.7 Starting system	49
1.8.2.8 Wiring and sensors	50
1.8.2.9 Variations and final decision	52
1.8.3. Materials.....	64
1.8.4. Manufacturing processes.....	65
1.8.5. Assembly description.....	66
1.8.5.1 Disassembly	68
1.8.6. Exploitation plan:.....	69
1.8.6.1 Brand image development	69
1.8.6.2 Packaging	70
1.8.7. Planification.....	72
1.8.7.1 Times calculation	72
1.8.7.1 Gantt	72
1.8.8. Economic study.....	74

2. APPENDICES.

Appendix 2.1 - Precedents.....	79
Appendix 2.2 - Webs	83
Appendix 2.3 - Survey.....	86
Appendix 2.4 - Ponderation	88
Appendix 2.5 - Neoprene suit thickness.....	91
Appendix 2.6 - Wetsuit access system.....	93
Appendix 2.7 - Different joint systems.....	95
Appendix 2.8 - PFD'S elevation force.....	96
Appendix 2.9 - Calculation.....	100
Appendix 2.10 - Charged battery.....	108

Appendix 2.11 - Different possible gas.....	112
Appendix 2.12 - Valve.....	113
Appendix 2.13 - Oxiometry	118
Appendix 2.14- Bone conduction.....	122
Appendix 2.15 - Material.....	123
Appendix 2.16 - Material comparison.....	126
Appendix 2.17 - Patents	128
Appendix 2.18 - Time Calculation	132
Appendix 2.19 - Suplies.....	137
Appendix 2.20 -Emails with dealers.....	139
Appendix 2.21 - Molds cost.....	140

3. BLUEPRINT.

Earbud	Blueprint 1
Earbud - Piece 1.....	Blueprint 2
Earbud - Piece 2.....	Blueprint 3
Earbud - Piece 3.....	Blueprint 4
Earbud - Piece 4.....	Blueprint 5
Piece inside the valve.....	Blueprint 6
Back case - Piece 1.....	Blueprint 7
Back case - Piece 2.....	Blueprint 8

4. CONDITIONS.

4.1 Material description and purchased elements	147
4.1.1 Purchased elements	147
4.1.2. Manufacturing elements	154
4.1.3 Joining systems	155
4.1.4 Minimum acceptable quality standards	155
4.2 Technical specifications of materials	156
4.3 Tolerances	156

4.4 Manufacturing requirements	157
4.4.1 Supplies	157
4.5 Assembly specifications.....	159
4.6 Specifications during the product operation	159
4.6.1 Usage	159
4.6.2 Maintenance	159
4.6.3 End of useful life	160

5. MEASUREMENT STATUS.

5.1 Cost of the purchased parts.....	165
5.1.1. Neoprene suit.....	165
5.1.2. Security.....	165
5.1.3. Electronic devices.....	166
5.1.4. Presentation.....	167
5.2 Raw material cost	167
5.3 Machinery cost	168

6. BUDGET

6.1 Considerations.....	173
6.. Cost product per unit.....	174
6.2.1 Raw material cost.....	174
6.2.2 Purchased pieces cost.....	175
6.2.3 Workers cost.....	175
6.2.4. Manufacturing cost.....	176
6.3 PVP.....	176
6.4 Viability, annual calculation and cash flow.....	177
6.4.1 Initial investment.....	177
6.4.2 Profitability and viability.....	178

1.REPORT



Report's Index

1.1. Object.....	12
1.2. Scope.....	12
1.3. Precedents.....	13
1.4. Standards and references	14
1.4.1. Legal provisions and applied norms/standards:	14
1.4.2. Bibliography	16
1.4.3. Informatic programs	18
1.4.4. Definitions and abbreviations	19
1.5. Design requirement.....	20
1.5.1 Problem definition.....	20
1.6. Objective definition.....	20
1.6.1 Circumstances around the design	20
1.6.2 Available resources	21
1.6.3 User profile	21
1.6.4 Objectives to follow	22
1.6.5 Analysis of the objectives	23
1.6.6 Specifications and restrictions	25
1.7. Analysis of solutions.....	28
1.7.1. Sketches and alternatives	28
1.7.2. Study of the alternatives	33
1.8. Final results.....	36
1.8.1. General description of the product	36
1.8.2. Detailed description of the product	37
1.8.2.1 The neoprene suit	37
1.8.2.2 Joining method	39
1.8.2.3 The float	39
1.8.2.4 Harness or sealed	40
1.8.2.5 Back pocket and CCS	41

1.8.2.6 The valve	45
1.8.2.7 Starting system	49
1.8.2.8 Wiring and sensors	50
1.8.2.9 Variations and final decision	52
1.8.3. Materials.....	64
1.8.4. Manufacturing processes.....	65
1.8.5. Assembly description.....	66
1.8.5.1 Disassembly	68
1.8.6. Exploitation plan:.....	69
1.8.6.1 Brand image development	69
1.8.6.2 Packaging	70
1.8.7. Planification.....	72
1.8.7.1 Times calculation	72
1.8.7.1 Gantt	72
1.8.8. Economic study.....	74

1.1 OBJECT

The object for the course DI 1048 end-of-degree project is to create a floating device that can take someone to the water surface in dangerous situations.

By gauging certain parameters, this device will be capable of determining when the user is at risk of drowning. The device will inflate the floating device allowing the user to ascend to the surface.

Potential consumers to which it will be aimed will be athletes or sport fans. Moreover, both the most appropriate location to place the floating device, and whether it will be manually operated or automatically launched will be studied in this project.

1.2. SCOPE

The product developed in this project was thought to be used by athletes that practice aquatic sports, and that could eventually face dangerous situations while practicing those sports.

It could potentially be found in both river and ocean aquatic activities such as surfing competitions, recreational sailing, rafting, windsurfing, kitesurf, among other similar sports that imply certain level of danger.

1.3 PRECEDENTS

There is a variety of products with many different purposes related to this project's target function, that could be considered precedents to this specific project.

Kingii: Floating device integrated in a bracelet that can be manually activated if the user is in drowning danger.



Image 1.3.1 - kingii

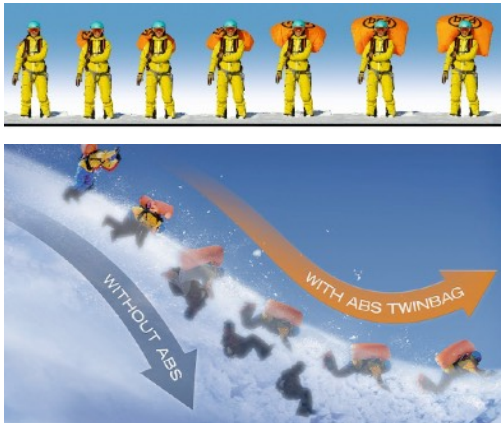

Image 1.3.2 - sky bags

Sky bags: Similar system used in snow environments that can pull the user up to the surface in case of an avalanche.

Or floating devices commonly used in the ocean or some other water bodies.



Image 1.3.2 - float device

In order to find more detailed information on these products and some of the other precedents considered for this project, go to **Appendix 2.1: Precedent** – Page: 79.

1.4. STANDARDS AND REFERENCES

The following section lists all the norms and regulations considered for the realization of this project:

1.4.1. Legal provisions and applied norms/standards:

General applicable standards for the project:

- Regulations for the develop of this project.

- UNE 157001:2014. Criterios generales para la elaboración formal de documentos que constituyen un proyecto técnico.
- UNE-EN ISO 9001:2000. Sistemas de gestión de calidad requisitos.
- UNE-EN ISO 9004:2000. Gestión de la Calidad y elementos del sistema de la calidad. Parte 1: directrices.
- UNE-EN ISO 8402:1995. Gestión de la calidad y aseguramiento de la calidad. vocabulario.
- UNE-EN ISO 11442:2006. Documentación técnica de productos. Gestión de documentos.
- UNE-EN ISO 19011:2002. Directrices para la auditoría de los sistemas de gestión de la calidad y/o ambiental.

- UNE rules for blueprint generation.

- UNE 1032:1982. Dibujos técnicos. Principios generales de representación.
- UNE 1039:1994. Dibujos técnicos. Acotación. Principios generales, definiciones, métodos de ejecución e indicaciones especiales.
- UNE 1027:1995. Dibujos técnicos. Plegado de planos.

- UNE 1135:1989. Dibujos técnicos. Lista de elementos.
- UNE-EN ISO 3098-0:1998. Documentación técnica de productos. Escritura. Requisitos generales. (ISO 3098-0:1997).

Specific applicable standards for the product:

- UNE rules.

- UNE-EN ISO 12403-7. Válvula de accionamiento manual del flotador.
- UNE-EN ISO 12402-7. Válvula de accionamiento automático del flotador.
- UNE-EN ISO 12403-7. Tubo de inflación oral del flotador.
- UNE-EN ISO 12402-7 and 8. Silbato de auxilio en flotadores.
- UNE-EN 393/A1, 395/A1, 396/A1, 399/A1. Información expuesta en los chalecos salvavidas sobre las características de estos.

- More rules.

- CE ISO 12401. Homologación en arneses de seguridad.
- ISO 9001. Garantía calidad en arneses de seguridad.
- ANSI Z359.1 y/o ANSI 10.32. Verificación calidad en arneses.

Specific regulations: Finishes and materials

- UNE-EN 201:210. Máquina de plásticos y caucho. Máquinas de moldeo por inyección. Requisitos de seguridad.
- UNE-EN 22768:1994. Tolerancias generales. Parte 1: tolerancias para cotas dimensionales lineales y angulares sin indicación individual de tolerancia.

1.4.2. Bibliography:

Books:

ANTROPOMETRÍA APLICADA AL DISEÑO DE PRODUCTO	
Publicación UJI, 2015	Margarita Vergara y María Jesús Agost

PROBLEMAS RESUELTOS DE SISTEMAS MECÁNICOS PARA EL DISEÑO INDUSTRIAL	
Publicaciones UJI, 2012	Antonio Pérez González, José L. Iserte Vilar, Octavio Bernard Ros

DISEÑO CONCEPTUAL	
Publicaciones UJI, 1999	M ^a Rosario Vidal Nadal, Antonio Gallardo Izquierdo, Ramos Barceló

INTRODUCCIÓN A LA CIENCIA E INGENIERÍA DE MATERIALES	
Reverté, 2007	William D. Callister

Document:

NOTES FROM SUBJECT: MATERIALS	
DI1010	UJI, 2015

NOTES FROM SUBJECT: MECHANICS AND RESISTANCE OF MATERIALS	
DI1013	UJI, 2015

NOTES FROM SUBJECT: CONCEPTUAL DESIGN	
DI1014	UJI, 2015

NOTES FROM SUBJECT: GRAPHIC DESIGN	
DI1017	UJI, 2016

NOTES FROM SUBJECT: DESIGN FOR THE MANUFACTURING I	
DI1020	UJI, 2016

NOTES FROM SUBJECT: DESIGN FOR THE MANUFACTURING II	
DI1021	UJI, 2017

NOTES FROM SUBJECT: DESIGN METHOLOGIES	
DI1022	UJI, 2017

NOTES FROM SUBJECT: PRODUCT-APPLIED ELECTRIC TECHNOLOGIES	
DI1027	UJI, 2017

NOTES FROM SUBJECT: ERGONOMICS	
DI1023	UJI, 2017

NOTES FROM SUBJECT: INCLUSIVE DESIGN	
DI1043	UJI, 2018

NOTES FROM SUBJECT: EMOTIONAL DESIGN	
DI1044	UJI, 2018

Chart 1.4.2.1 - Bibliography

Webs:

In order to carry out this study, an extensive information research that involved websites and projects from students of some other Universities has been made. The link to this bibliography package can be found as **Appendix 2.2** in the Appendixes section - Page 83.

1.4.3. Informatic programs:

TEXT



Google Drive



Pages

3D MODELATE



3D Max



Autocad

RENDER AND PHOTOGRAPHY



Illustrator



Photoshop

SKETCHES



Procreate

Chart 1.4.3.1 - Apps

1.4.4. Definitions and abbreviations.

TÉRMI	ABREVIATON
Polyvinyl chloride	PVC
Carbon dioxide	CO ₂
Hemoglobin	Hb
Oxihemoglobin	HbO ₂
Helium	He
Wireless Power Consortium	WPC
Global Positioning System	GPS
Ultra violet	UV
European Conformity	CE
European Norm	EN
International Organization for Standardization	ISO
Una Norma Española	UNE

UNITS	ABREVIATON
Grams	g
Liters	L
Microns	μm
Meters	m
Milimeters	mm
Watts (electric power)	W
Amperes	A
Newton	N
Volts	V
Temperature in Celsius degrees	°C

Chart 1.4.4.1 -Definitions and abbreviations

1.5 DESIGN REQUIREMENT

1.5.1 Problem definition

There are many dangerous situations in the water all around the world. And in the market there are no products that can satisfy this problem.

This problem can be solve creating a new device capable of saving lives in aquatic dangerous situations, allowing to the user to ascend up to the water surface manually or automatically.

1.6 OBJECTIVE DEFINITION

1.6.1 Circumstances around the design

Economic factors: In the aquatic sports every object is quite expensive, the clothes, materials, displacement... For these reasons, the idea to introduce a new object in that market will make that the users think about the necessity of buy it or not.

Social facts: Using this gadget the users can look like more clumsy for use this security system however they can seems more prepare for hard conditions and at the same time worried about their security.

Environmental factors: Like other brands this study will try to use recycling materials, like neoprene or plastic. It is known that for the users it is very important the materials, how we produce the object and how respectful are we with the environment.

1.6.2 Available resources

This section name all the resources that the study has to make the conceptual study and the other parts of the project.

- Users.
- Personal Experience.
- Computer with specific programs and internet.
- Acquired knowledge during internship.
- Professors ans specific subjects.
- Authorization and support of the TFG's mentor.
- Academic resources.

1.6.3 User profile

PROFILE OF THE TARGET MARKET	
GENDER	Indistinct
AGE	15 to 50 years old
POPULATION	Coastal areas or river-closed areas
SOCIAL CLASS	Medium – High to High
INCOME RANGE	20000- 50000€
CONSUMPTION PATTERNS	Willing to pay a higher price for a product that offers safety and that satisfies their needs.
PERSONAL VALUES	Committed with the environment, always trying to respect it and take care of it.
PERSONALITY	Adventurous, athletic, reckless but at the same time worried about its own safety.
LIFESTYLE	Altruistic, adventurous, nomadic, simple and always surrounded by nature.

Chart 1.6.3 - User profile

1.6.4 Objectives to follow

The market has been studied and now it is possible to know the problems to analyze and try to solve. For that it is included the design objectives among which we can highlight legal objectives, designer objectives and users objectives. Para ello se va a calificar como **O** los objetivos optimizables , **R**, como restricciones y **W** como wishes.

Legal objectives:

1. Non-patented design. **R - TOP**
2. Comply with all the previously mentioned regulations. **R - TOP**

Designer objectives:

3. Lightweight. **O**
4. Resistant G. **O**
5. Durable. **O**
6. Easy to put on and take off. **O**
7. It must not disturb the user while it is playing a sport or doing some other similar activity. **O**
8. It should be intuitive when being put on or taken off. **O**
9. It could be made out of recycled materials. **O**
10. Efficient. **O**
11. Easy to store. **O**
12. Customizable. **W**
13. Nice aesthetic but nothing striking. **O**
14. Economically accessible to as many users as possible (€) . **O**
15. Small. **O**
16. It fulfills the user's expectations . **O**

Manufacturing objects:

17. As easy as possible **O**
18. Easy-to-handle materials. **O**
19. Recycled materials . **O**
20. Its deterioration should happen as late as possible. **O**

- 21. Integrate only standardized elements in the design. **R**
- 22. Easy-to-assemble product. **O**
- 23. Relatively easy packing. **O**
- 24. Requires very few resources to be produced. **O**
- 25. Very little contamination. **O**
- 26. Easy to clean. **O**
- 27. As short as possible. **O**
- 28. As cheap as possible. **O**
- 29. Minimum maintenance required. **O**

Post-manufacturing object:

- 30. Accessible market price. **O - TOP**
- 31. As attractive as possible. **O**
- 32. As many sales as possible. **O**
- 33. Easy to transport. **O**
- 34. Satisfy user's expectations. **O**

1.6.5 Analysis of the objectives

In order to reduce the number of objectives to reach, a series of diagrams that correlate all the different objectives is made. These diagrams help defining a hierarchy that establishes which objectives are more relevant, and which of them are similar enough to be merged into one single one. All 34 objectives are categorized in certain groups depending on what they refer to:

- Aesthetic.
- Economic.
- Manufacturing
- Materials
- Functioning.

Primary objectives' diagram:

Aesthetic:

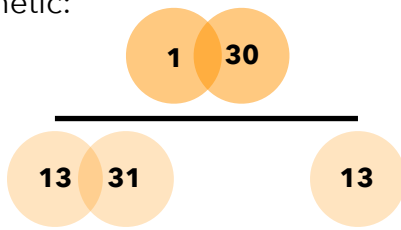

Functioning:

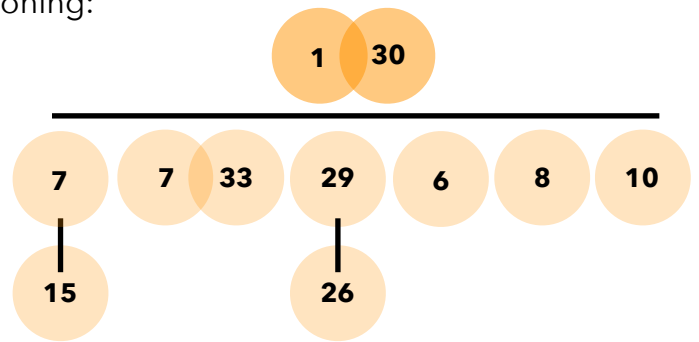

Economic:

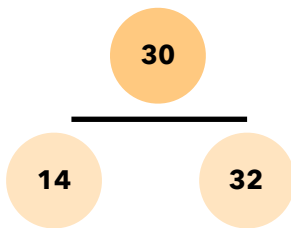

Manufacturing:

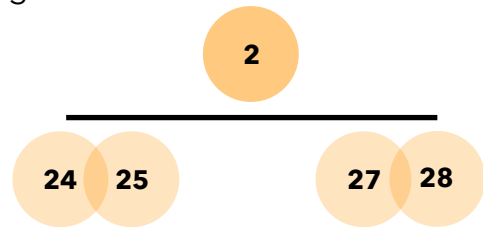

Materials:

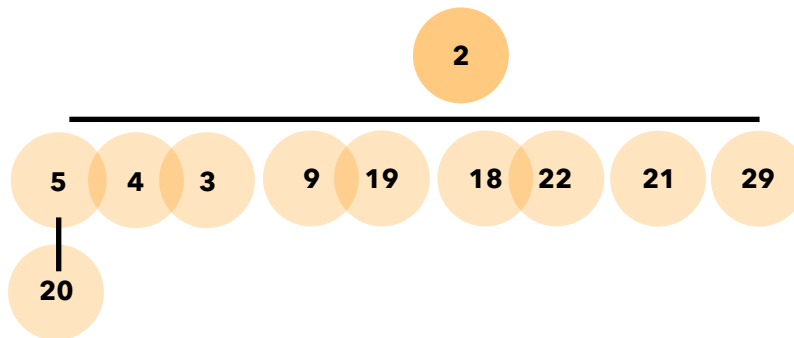

Chart 1.6.5.1 - Objective diagram

When creating these diagrams, it can be appreciated that some of these objectives are actually very similar to each other, which means they can be merged into one single one.

5. Durable = 20. Its deterioration should happen as late as possible

14. Economically accessible to as many users as possible (€) = 30. Accessible market price

16. It fulfills the user's expectations = 34. Satisfy user's expectations

3. Lightweight and 15. Small = 7. It must not disturb the user while it is playing a sport or doing some other similar activity.

13. Nice aesthetic but nothing striking = 31. As attractive as possible

9. It could be made out of recycled materials = 19. Recycled materials

1.6.6 Specifications and restrictions

This chart establishes the variable, criteria, and scale of all the objectives. As it can be seen, those objectives that were merged with a similar one in the previous section have already been deleted, for they had the same purpose. Wishes and restrictions are also not considered in this chart.

OBJECTIVE	SPECIFICATION	VARIABLE	STANDARD	SCALE
3. Lightweight.	The producto must be as light as possible	Weight	The lighter the prouct, the better	Proportional: Kg
4. Resistant G.	It should resist as many impacts as possible, and it must be water-resistant.	Resistance	The more resistant to impacts and water, the better.	Multidimensiona l: kg , cm3
5. Durable.	The producto should last as long as possible	Time	The longer the product lifetime, the better	Proportional - hours
6. Easy to put on and take off.	The putting-on time should be as short as possible	Time	The less time needed, the better	Proportional - minutes
7. It must not disturb the user while it is playing a sport or doing some other similar activity.	It should not bother the user while he/she is performing its activity	Comfort level	The less it bothers the user, the better	Ordinal - no discomfort, a little discomfort, uncomfortable, and too uncomfortable

8. It should be intuitive when being put on or taken off.	The product needs as little set up time as possible	Time	The fewer buttons and the clearest the design is, the better.	Proportional - minutes
9. It could be made out of recycled materials.	The more recycled materials used, the better	Amount of recycled materials used.	The more recycled materials, the better.	Ordinal: 1,2,3... Number of materials
11. Easy to store.	Once the product has been stored, it should take up as little space as possible	Occupied volume	The least space it occupies, the better.	Proportional: cm ³
15. Small.	The space occupied by the product should be as small as possible	Occupied volume	The size of the product should be as small as possible	Proportional: cm ³
17. As easy as possible.	The fabrication process should have as few steps as possible	Number of steps	The fewer steps, the better its value.	Ordinal: 1,2,3... Number of steps
18. Easy-to-handle materials.	It should incorporate the easiest-to-machine materials	Easiness when machining	The easy-to-machine materials will be positively valued	Ordinal - easily machinable, machinable, hardly machinable
21. Integrate only standardized elements in the design.	The design must integrate as many standard elements as possible	Number of standard elements	The more standard elements, the better	Ordinal: 1,2,3... Number of elements
22. Easy-to-assemble product	It should integrate easy-to-assemble materials	Easiness when assembling	The easy-to-assemble materials will be positively valued	Ordinal - easy to assemble, hard to assemble

24. Requires very few resources to be produced.	It consumes the least amount of resources possible	Number of required processes and materials	The fewer amount of steps and materials, the better	Ordinal - 1,2,3... Number of steps and materials
25. Very little contamination.	The environmental impact should be as little as possible	Kg of CO ₂ emitted during fabrication	The fewer Kg of CO ₂ emitted during fabrication, the better	Proportional: Kg
27. As short as possible.	The fabrication process should be as short as possible	Time	The less time required, the better	Proportional - hours
28. As cheap as possible.	The process should be as cheap as possible	Price	The cheaper, the better	Proportional - euros
29. Minimum maintenance required.	The required maintenance should be as little as possible	Time	The less maintenance time required, the better	Proportional - minutes
30. Accessible market price.	The price should be as little as possible	Price	The cheaper, the more attractive	Proportional - euros
31. As attractive as possible.	The product should be as attractive and newfangled as possible	Amount of people that like it	The design that attracts the most people will be the best one.	Ordinal - 1,2,3... Number of people that feel attracted
32. As many sales as possible.	The product should produce as many sales as possible	Number of sales	The more the sales, the better the product	Ordinal - 1,2,3... Amount of products sold
33. Easy to transport	The product should be able to be transported in the easiest way possible	Comfort level	The easier its transportation is, the better	Ordinal - very comfortable, not comfortable
34. Satisfy user's expectations.	The product should satisfy the user in as many ways as possible	Satisfaction level	The more satisfied the user is, the better	Ordinal - very satisfied, not satisfied at all

Chart 1.6.6.1 - Objectives

1.7 ANALYSIS OF SOLUTIONS:

1.7.1. Sketches and alternatives:

This section will describe the different alternatives that have been studied in order to come up with an optimal solution for this project. There are five distinct alternatives:

The first idea and the main reason why this project started in the first place was the “**PIFLOT**” (original name of this idea) floating bracelet. This bracelet can monitor both the user’s heartbeat and its level of blood oxygen saturation, and then use this data to determine whether the floating device should be automatically activated depending on the user’s current situation. This bracelet could also be manually activated at any time.

The “manual” way to activate the bracelet is by pushing two buttons (just in case one of the buttons is involuntarily pushed for some reason). On the other hand, the automatic way would be driven by a pulsometer capable of monitoring the user’s heartbeat, and an oximeter that can determine the level of blood oxygen saturation.

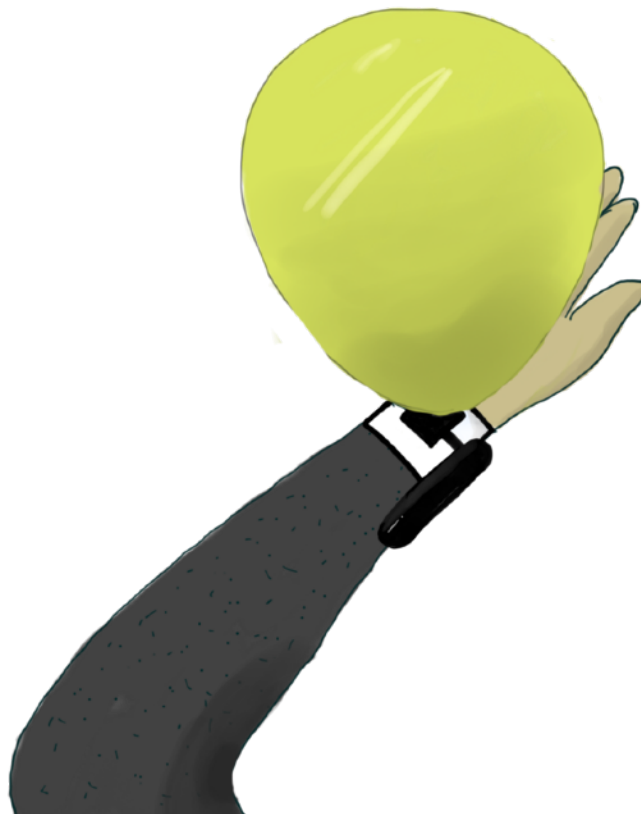

Sketch 1.7.1.1 - Alternative 1

The second possible solution would be a considerably smaller bracelet that would not have an integrated floating device, but a GPS and an emergency system that could notify the corresponding authorities in case the user found itself in a dangerous situation. This bracelet would also have a pulsometer and an oximeter as ways to determine whether the user was drowning, case in which the emergency call would be activated.

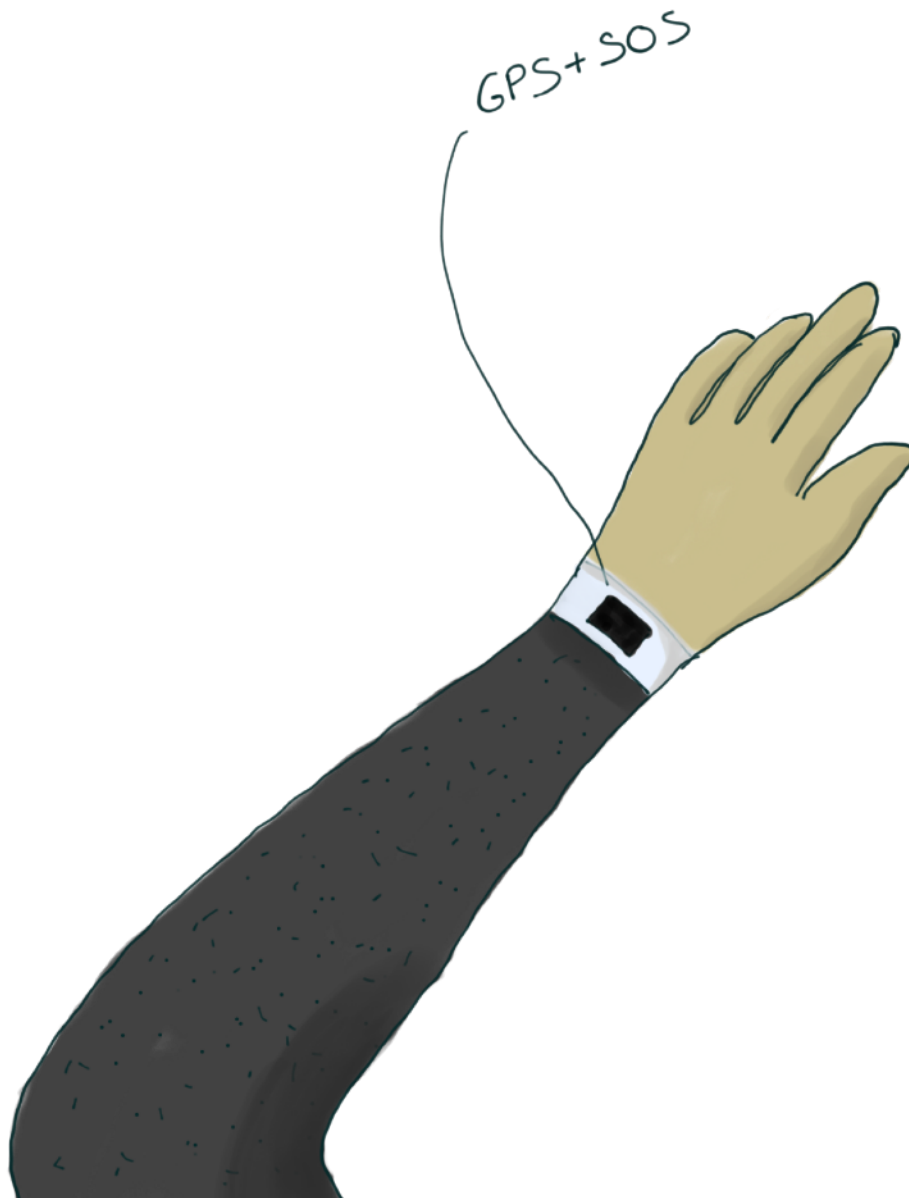

Sketch 1.7.1.2 - Alternative 2

The third and fourth alternatives are very similar systems, being the only difference between the two of them the body part in which it was supposed to be placed.

The third option consists of a vest that the user could wear over its clothing, and that contains a floater on the chest area. This alternative would also integrate a bracelet with the same two variables mentioned in previous options (pulsometer and oximeter) that would communicate with a processing unit integrated in the vest via Bluetooth or radio frequency.

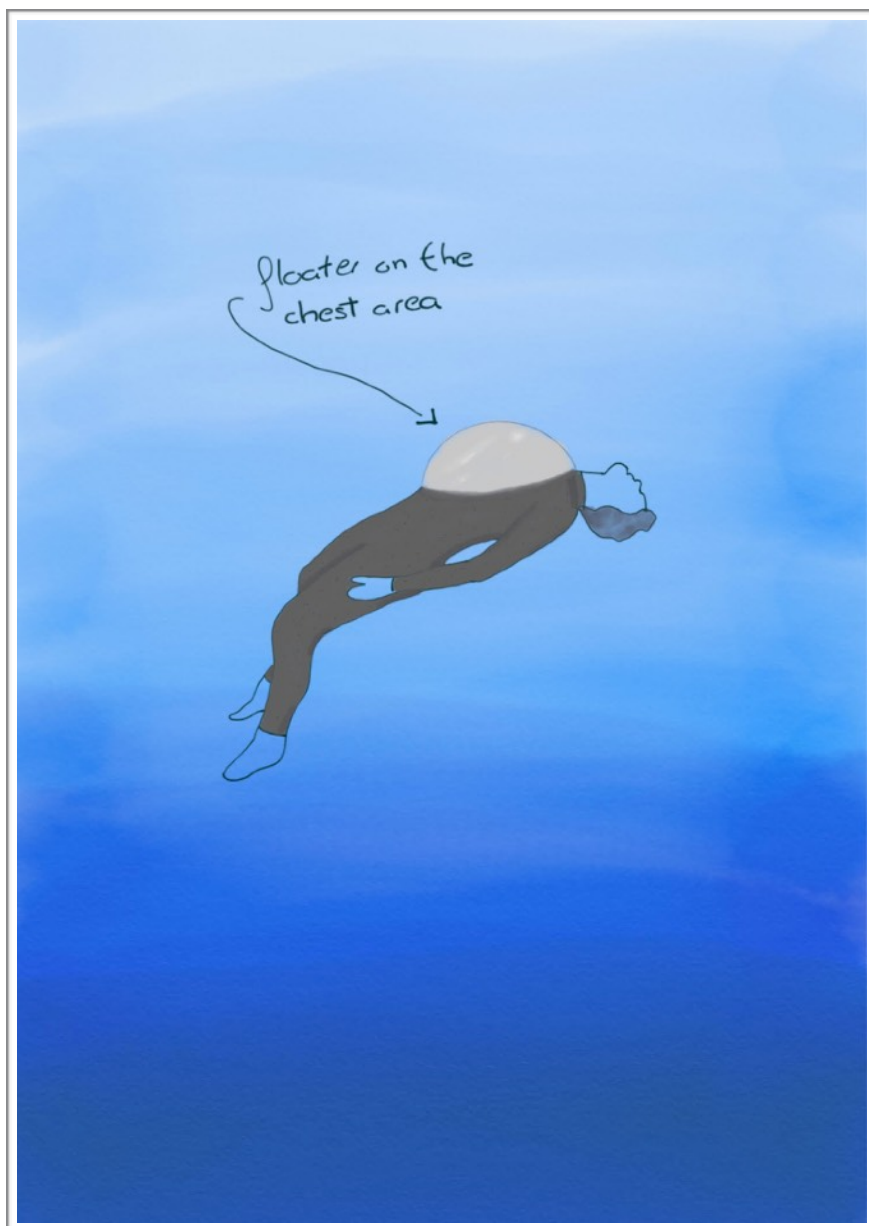

Sketch 1.7.1.3 - Alternative 3

On the other hand, the fourth option is basically the same system and functioning of the third alternative, except that the floater would be located at the back area of the vest. Having the floater on the user's back would be more comfortable and would cause less interference with whatever activity the user is doing.



Sketch 1.7.1.4 - Alternative 4

The fifth possible solution would consist of a full neoprene suit. This alternative required an investigation on the design of existing lifejackets already available in the market, and it was decided to follow one of these designs by placing the floater (that would be located inside the suit) on the chest area and all around the user's neck. The floater would come out through some slots on the suit that could only be opened by the pressure generated when inflating that floater. This alternative would also integrate a wrist device that could measure both heartbeat and the blood oxygen saturation, and it would then send this data to a processing unit located at the top back area of the suit.

The floater would be hooked around the user's body by using a harness that would surround it. The processing unit located at the back area would also be hooked to this harness, and this supporting system would all be located under the neoprene layer of the suit. In order to improve the user's comfort level, a thin layer of neoprene would be added right between the user's body and the previously mentioned harness.

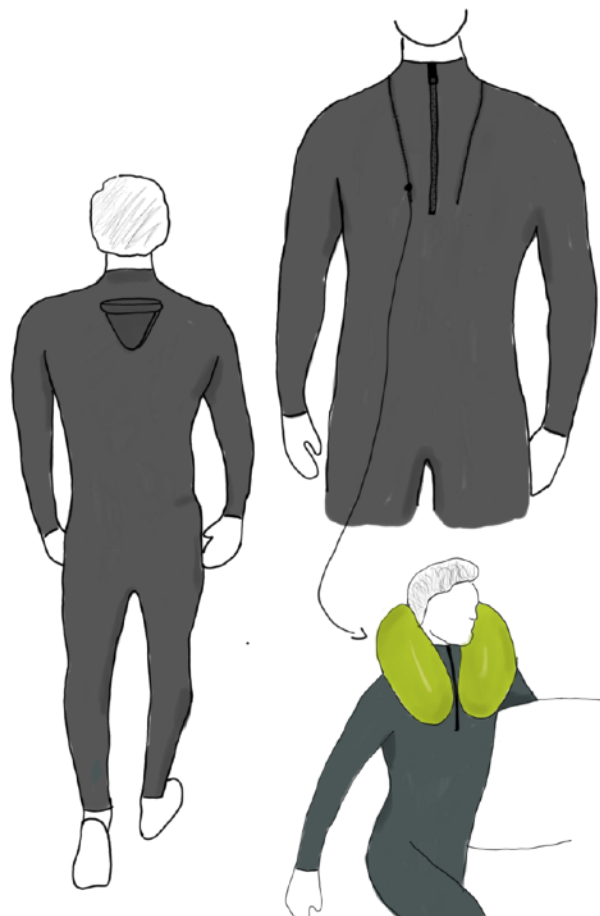

Sketch 1.7.1.5 - Alternative 5

1.7.2. Study of the alternatives:

A small survey was run with 10 potential users of this product (ocean activities athletes), and they were shown a list of the most relevant objectives so they could point the more important ones for them. This information would help determine which of the alternatives were closer in functioning and perform with whatever the group of users was looking for.

The top ten most important objectives are the following:

- 7. It must not disturb the user while it is playing a sport or doing some other similar activity.
- 30. Accessible market price.
- 3. Lightweight.
- 6. Easy to put on and take off.
- 15. Small.
- 8. It should be intuitive when being put on or taken off.
- 29. Minimum maintenance required.
- 5. Durable.
- 9. It could be made out of recycled materials.
- 10. Efficient

More detailed information on this survey can be found in **Appendix 2.3** – Page 86.

These ten objectives, selected as the most important ones in the survey, will be used to rate the different alternatives using the following scale:

- Do not meet the objective = 0
- Slightly meet the objective = 0.25
- Meet the objective = 1

PONDERATION	
FIRST ALTERNATIVE - PIFLOT	5
GPS + SOS BRACELET	7,5
CHEST FLOAT	5,25
BACK FLOAT	5,25
NEOPRENE SUIT	7,25

Chart 1.7.2.1 - Ponderation

In order to make sure what the best alternative is, a second method was used, the **DATUM** method; one of the alternatives is selected as a starting point and it is then compared to the rest of the options, obtaining the best one among all of them.

	PIFLOT	GPS + SOS BRACELET	CHEST FLOAT	BACK FLOAT	NEOPRENE SUIT
Efficient	-1	-1	D	0	1
Discrete	-1	1	A	0	1
Ergonomic	-1	1	T	0	0
Safe	0	-1	U	0	1
Comfortable	-1	1	M	1	1
Economic	0	1	-	0	-1
	-3	2	-	1	3

Chart 1.7.2.2 - DATUM

All the information regarding the weighing criteria and options can be found in **Appendix 2.4: Ponderation** -Page 88.

It can be observed that in both methods, the alternatives GPS + SOS Bracelet and Neoprene Suit obtained higher scores than the rest of the options.

However, once again, these results were purposely questioned, as well as the reason why these various alternatives ended up being rejected as a possible solution to this project. Considering that:

- **PIFLOT:** This first alternative met this project's main objective: "By gauging certain parameters, this device would be capable of determining when the user is at risk of drowning. The device will inflate the floating device allowing the user to raise to the surface" OBJECT 1.1. However, this device's placement would not be the most adequate, for due to its weight, it would considerably bother the user while performing its activity. On the other hand, if the user was unconscious, the bracelet would detect it, it would inflate the floater and eventually pull the user up to the surface, but it would not be able to keep its head above the water, which means the user would eventually die. It would only help locating the user's dead body.
- **GPS + SOS Bracelet:** This idea could be integrated as part of the final solution, but it would not work on its own because it is not capable of pulling the user up to the water surface, which means it does not meet the project's main objective. Even though it has a GPS location system, it would only help finding a body that is still under water.
- **Chest vest and back vest:** The situation with these two alternatives is fairly similar to that of the first option (PIFLOT); the floating device could be automatically activated, and it would take the user up to the water surface, but it cannot guarantee the user's head will be out of the water at all times. These alternatives should be better studied before they can actually be considered possible solutions for this project.

- **Neoprene suit:** Even though this is the safest option for the user, it is also the biggest and the most expensive one, for it consist of a full neoprene suit.

Finally, the most important aspect of the chosen solution is that it fully meets this project´s main objective: a product that can be manually or automatically activated and that can take a person up to the water surface; this objective can only be met by the **Neoprene suit** alternative.

Therefore, this alternative was the chosen one to be developed in this study.

1.8 FINAL RESULTS

1.8.1 General description of the product

The final product is a neoprene suit intended for sport activities that is capable of being manually partially inflated; the user can pull a rope that will open the **CO₂** capsule in order to fill the float. On the other hand, the suit can also be automatically inflated, for it is constantly monitoring the user´s status (vital signs) in order to be able to pull him/her up to the water surface and keep it there in case of being in a dangerous situation.



Sketch 1.8.1.1 - General description

1.8.2 Detailed description of the product

The selected product consists of various different elements; in order to properly explain every part in a clear and simple manner, each of them will be addressed and explained individually.

1.8.2.1 The neoprene suit:

It will be composed by two parts, an inner layer in direct contact with the user, and an outer layer in contact with the ambient. All the other parts of the design will be located in between these two layers;

- The inner layer consists of a short body-type suit with suspenders that will originally be 1 mm thick. This thickness will be modifiable by the user, so the suit can better fulfill its needs.

- The outer layer will consist of a non-modifiable 2 mm thick neoprene fabric.

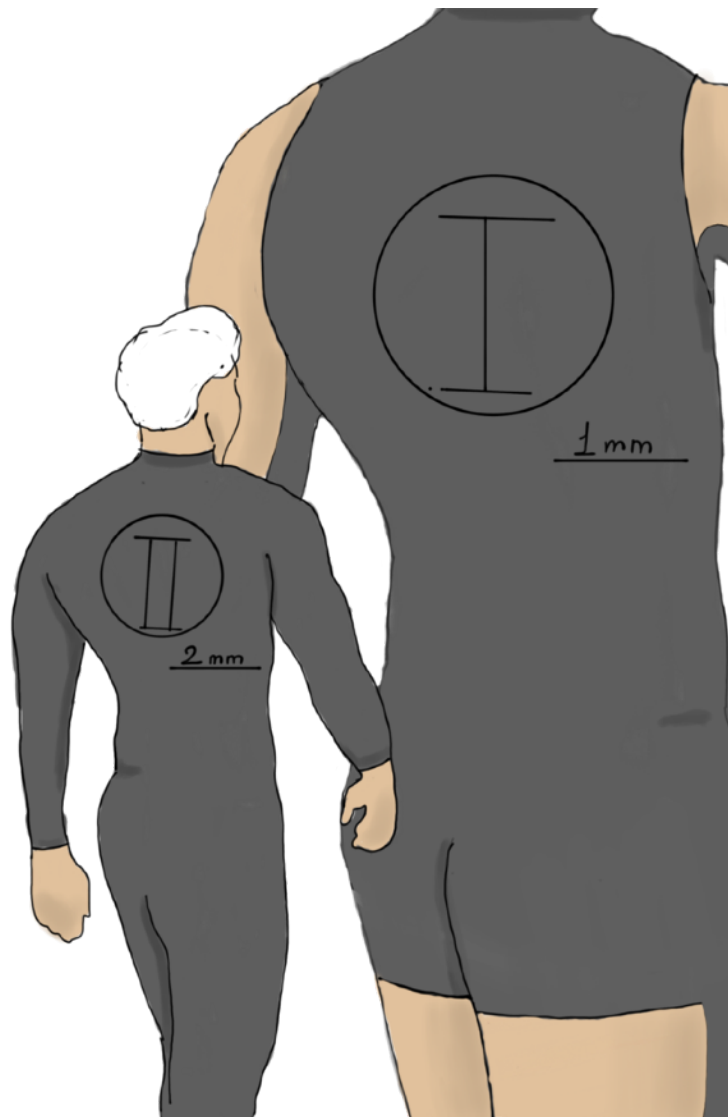

Sketch 1.8.2.1 - Two layers

These two parts will be joined together using the “Sealed and Taped” method in the following areas: neck, shoulders, groin, and right next to the zip that will be used to access the suit.

In order to better understand the reasons why these thicknesses were selected, more information can be found in **Appendix 2.5: Neoprene suit thickness** - Page: 91

There are several ways to access a neoprene suit, all of which are explain in **Appendix 2.6: Wetsuit access system** - Page 93. However, the chosen one for this design was the

front zip, for, as it will be later explained, the back area has been reserved for a different purpose, and the neck system could be a little more complex and/or uncomfortable for the user.

1.8.2.2 Joining method:

The neoprene layers will be joined together by using the “Sealed and Taped” method, for it provides a better insulation and avoids chafing on the user’s skin. This process consists on sewing the different layers of neoprene using twine thread, and then gluing an extra layer (excess parts when cutting the layers) on top with heat adhesive in order to prevent water from trespassing the seams. Deeper information on this topic can be found in **Appendix 2.7** – Page 95.

1.8.2.3 The float:

In between these two layers of neoprene, **the float** will be carefully placed so it bothers the user at least as possible. When it gets inflated, it will come out through some openings located at the outer neoprene layer, but these openings will be normally closed using Velcro-type tape. The pressure generated by the float when it gets inflated will be strong enough to detach these Velcro tapes.

The float will cover the chest area, and it will go all around the user’s neck . Moreover, it has appropriate reflective bands, all the explanations and usage warnings, and its buoyant force is that of 150 N. The buoyant force means how strong is the float in order to buoy a certain amount of mass. All the pertinent calculations and explanations on this topic can be found in **Appendix 2.8** – Page 96.

Finally, it is important to mention that there will be a cable connecting the valve outlet from de SCC “Sistema de contra central” and the float inlet; this cable will transmit air from one place to the other one.



Sketch 1.8.2.3- connection between float and valve

1.8.2.4 Harness or sealed:

Harness: The first option consisted on adding a harness with its corresponding adjusting and closing buckles in the rear part of the suit, at the pocket height, in order to be able to get to them and adjust them to the user. However, this option presented a series of inconveniences:

- It would be heavier for the user.
- It would be more uncomfortable when moving.
- More materials would need to be purchased, and therefore the fabrication process would be longer and more expensive.

However, when analyzing it with Ana Martinez Iserte (Haute couture professional that will later advise on prices, schedules, necessary machines for neoprene suit manufacturing) she advised that a double seam between the float and the inner neoprene layer would make the harness completely unnecessary.

DISCARDED

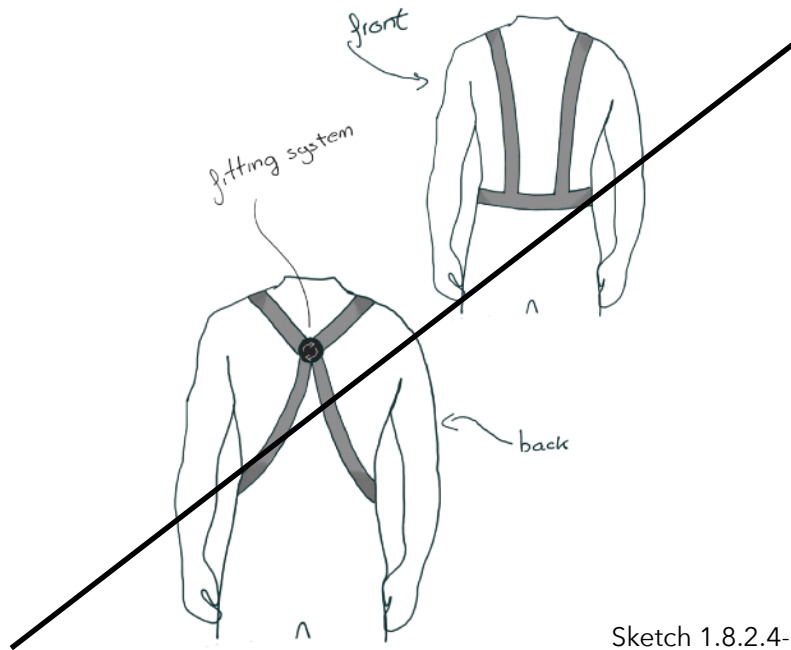

Sketch 1.8.2.4- Harness

After observing the different backs of all the surveyed ones, it was understood that the selected shape was not the most adequate one, for it would bother the upper back muscles. Therefore, in order to improve the suit's comfort, this shape was placed upside down.



Image1.8.2.4- Back photos

1.8.2.5 Back pocket and CCS:

Moving to the back part of the suit, the pocket that will contain the device (called Central Control System CCS) that will control the whole system can be appreciated.

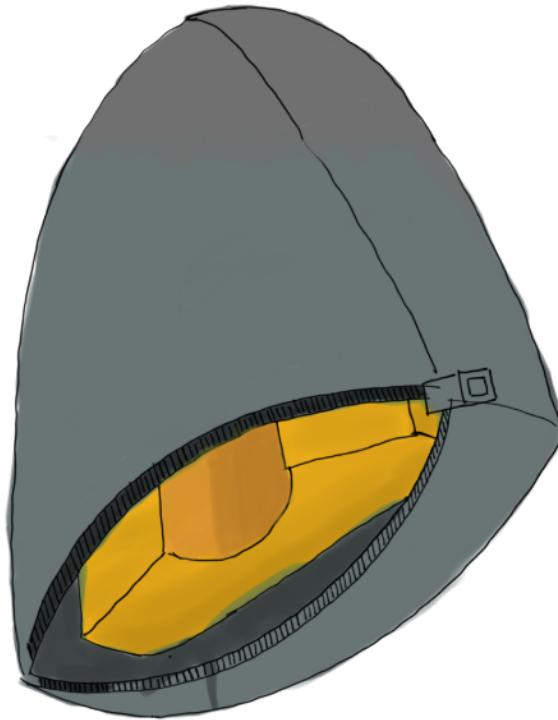

Sketch 1.8.2.5.1 - SCC

This product's case will be made up of two parts (as it will be seen in block *Blueprint*) that are snapped together, which means the adjustment needed for its fabrication is H5n5. This adjustment guarantees that these parts will not easily let go from each other ($F_{min} = 15N$), but at the same time, a user or a technician could open the case without any special tool ($F_{to\ open} = 110\ N$). All these data can be found in Appendix 2.9: Calculations - Page ---

The following components can be found inside the CCS:

-**Battery;** A wireless-charged battery was chosen for this project. This decision was made after a deep research on different charging options, and specifically on the functioning of wireless charging, was carried out. More information can be found on **Appendix 2.10** - Page 108.

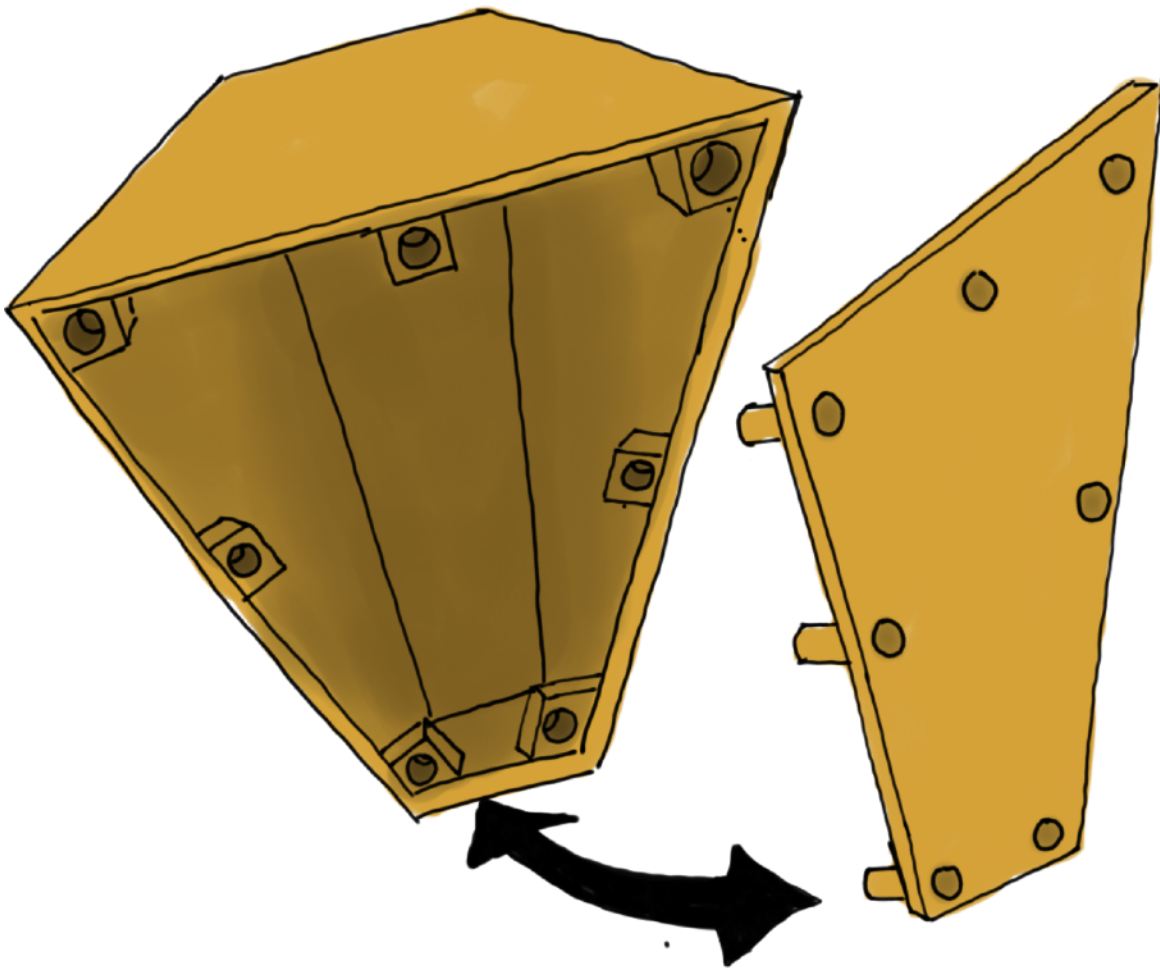

Sketch 1.8.2.5.2 - Two pieces SCC

- **Qi battery receiver;** this element's function consists on charging the battery. As it is explained in Appendix 2.10. This charge receptor receives the magnetic field created by the charging plate (this plate is not included with this product) and transforms it in order to charge the system's battery.

-**Arduino;** Capable of processing the different monitored values and give the orders so the design can properly operate. The Arduino programming is out of this project's scope, but it is being considered on the budget. It consists of a series of installed parts that are needed for it to correctly operate.

- **C port:** used to connect the charge receiver to it.
- **Wiring:** All the necessary to connect it with the rest of the design.
- **Microphone:** To listen to the user the he or she said "OKAY".

-**Gas capsule used to inflate the float;** CO₂ capsules were selected for this purpose due to their market availability, and for the savings that not having to manufacture a special capsule would represent. Even then, research was made on different possible gases that could have been used for this project; more information can be found in **Appendix 2.11** - Page 112.

As it can be observed in the following sketch, the CO₂ capsule will be introduced in the CCS only through its threaded end. This capsule will be directly screwed in to the valve that will be placed in this end hole.

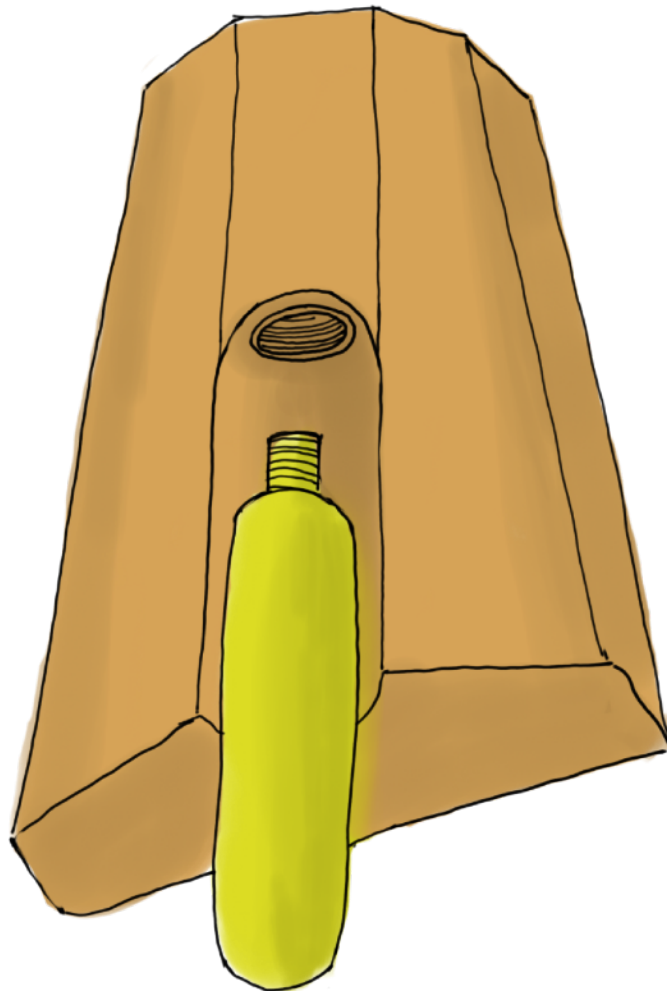

Sketch 1.8.2.5.2- Valve entry

DIMENSION OF THE PIECES THAT CAN BE FOUND INSIDE THE SCC	
Arduino	4,2 x 3,6 x 0,8 mm
Battery	136 x 42 x 16 mm
Battery receiver	104 x 43 x 7 mm
Valve	60 x 40 x 75 mm
Male threaded tube adapter	40 x 30 x 30 mm

Chart1.8.2.5- dimensions

Finally, it is worth mentioning that this pocket will consist of double neoprene layer and thermo-adhesive sealing, in order to provide better impermeability to this space and prevent water from entering the system. In any case, the exit and entrance holes that will be made in the case will have a bigger adjustment, in order to get the dimensions right and prevent water from entering the system.

1.8.2.6 The valve:

Very important part of the project. Research was made on many different options to detonate the CO₂ capsule, either mechanically or electronically, but at the end an electro-valve was chosen for this purpose. The selected valve is a normally closed electro-valve, which means that it does not let the fluid flow (air in this case) until an electric signal causes its piston to open, letting the air flow through the valve.

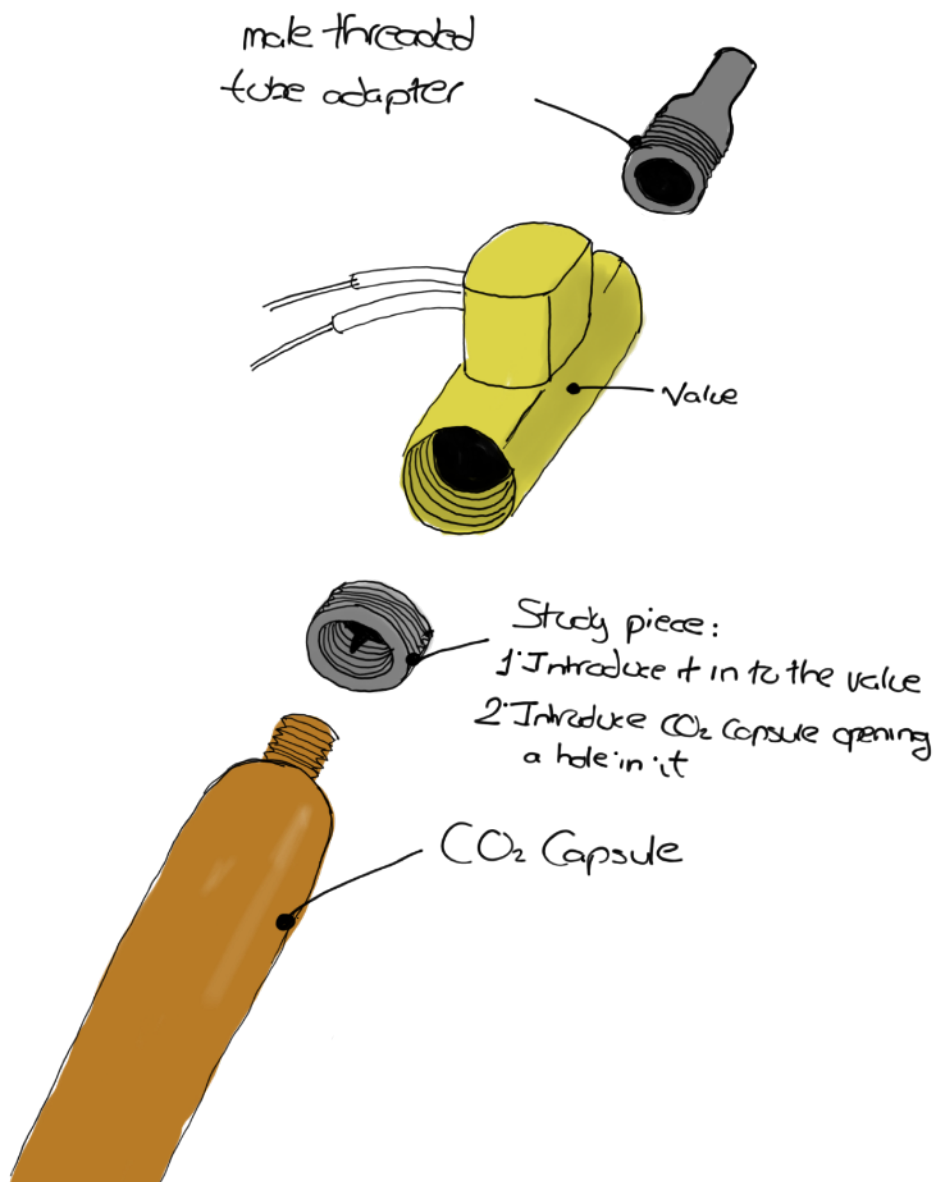

Image1.8.2.6.1- Valve

All the information on this kind of valve, and on all the other options that were considered to be used in this project, can be found in **Appendix 2.12** - Page 113.

The CO₂ capsule has a thread diameter of 12 mm the same as the valve, so it is perfect. The valve that have been choose it is 1/4" inch that in the specifications of the product on the web they say that the tread diameter is 12 mm. The only problem is that this valve has no kind of needle to penetrate and open this capsule.

The idea of placing a third part in between the CO₂ capsule and the valve was considered. This part would have an external thread that would fit in the 12 mm of the capsule and it would also have a sharp piece capable of penetrating and opening the capsule. Air would be kept in this cavity until the valve opened, letting it flow through it



Sketch 1.8.2.6.2- Pieces explosion

At the beginning, the manually-activated system for the float was thought as a rope that would open the CO₂ capsule when being pulled, just the same way that conventional floating systems available in the market work. However, this design does not allow this kind of system, for the rope could not help opening the capsule in any way.

But taking advantage that an electro-valve is already being considered, a different way for solving this problem was developed. Place two buttons, not just one, in order to avoid involuntary activation (error tolerance) located at the upper part of the left shoulder, close to it. The user would have to keep both buttons pushed for at least 3 seconds, in order to make the Arduino send the signal to the electro-valve to open and inflate the float.

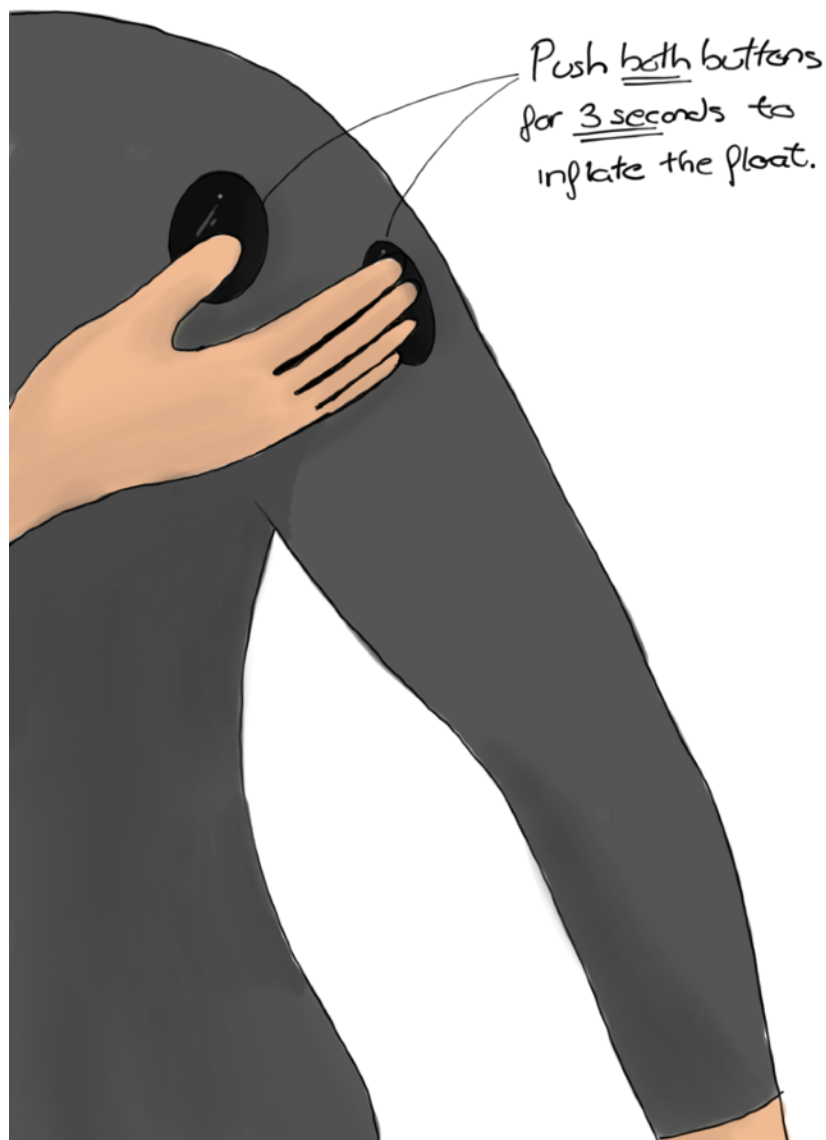

Sketch 1.8.2.6.3- Manually- activated

The placement of these two buttons has been studied so they are ergonomically positioned for the user, considering both their location and the distance between the two of them.

DATOS ANTROPOMÉTRICOS	
	Denominación 33. Longitud del dedo índice.
	Descripción Distancia desde la punta del dedo índice hasta la arruga proximal en la palma de la mano. Con el dedo extendido.
	Consideraciones de aplicación Guantes, distancias de seguridad en orificios en los que cabe un dedo.
	Denominación 34. Anchura proximal del dedo índice.
	Descripción Distancia máxima entre la superficie medial y la lateral del dedo índice medida sobre la articulación interfalángica proximal.
	Consideraciones de aplicación Holgura para el dedo en pulsadores, aberturas, etc. Considerar correcciones por el uso de guantes.

Image 1.8.2.6.4 - Antropometric measure

The user can push them in the most comfortable way possible, for he/she will not have go through any uncomfortable hand position in order to push them both at the same time. The location of these buttons was also chosen so that, even if it requires an uncomfortable position, they can be pushed with the other hand too. The two buttons could be en each should, it will be up to the users which side do they want.

An finally at the end of the SCC it can be found at the valve exit, a male threaded tube adapter will be added so the valve exit size can be adapted to the adequate size of the cable that will be connected to the float.

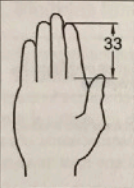
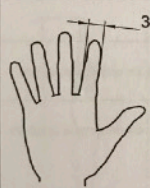

Image 1.8.2.6.5 - male threaded tube adapter

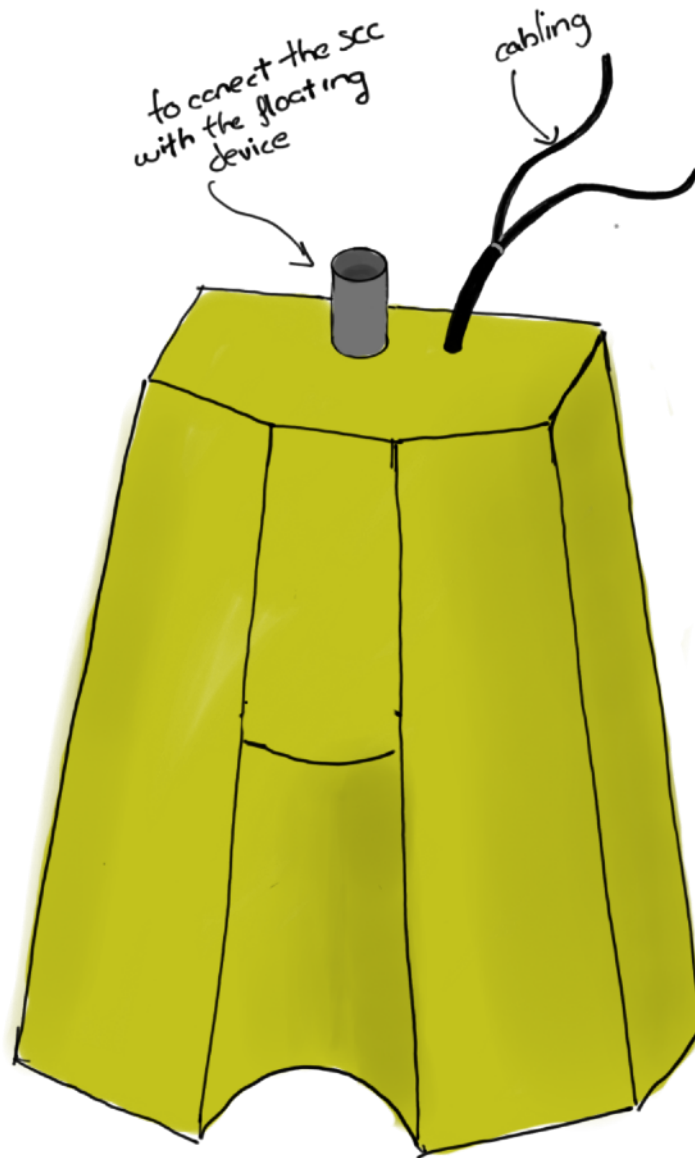

Sketch 1.8.2.6.6- SCC exits

1.8.2.7 Starting system:

Taking advantage of the fact that the activation buttons were mentioned in the previous section, their other functions will now be explained.

Both when turning the system on or off, the user has to push one of the buttons (1 second), any of them, but not both of them and they should not be kept pushed for 3 seconds. After this is done, a previously mentioned speaker located at the Arduino will react with a "Beep", letting the user know that the system is now on or off.

1.8.2.8 Wiring and sensors:

The “automatic” way of operation of the design will now be explained.

At the beginning, in the alternatives’ study, more than one, including the chosen one, considered the idea of integrating a pulsometer and an oximeter (**Appendix 2.13** - Page 118) in the user’s wrist.

The values provided by these devices were thought to be the key to know whether the user was in a dangerous situation, either because he/she was facing a drowning experience or had passed out.

However, after investigating with students and workers of the sanitary sector, and specially with Nadia Paulina González (Biomedical engineer in Monterrey Institute of Technology and Higher Education, Guadalajara, México). She warned about different possible problems:

- Movement: The transducer is commonly placed in a finger, and its movements can considerably affect its reliability (for example, the vibrations generated in an ambulance). It would be more reliable to put it on the ear. There will have less vibrations.
- There are too many veins and arteries in the wrist, which makes it fairly complicated to obtain trustworthy data when measuring the blood oxygen saturation in this body zone.

So that idea was discarded.

Another alternative was: To put different vibration/movement sensors will be placed in the user’s articulations, two of them in their knees, and another two in their elbows; an extra sensor will be located in its back, right down its neck.

These sensors will be wired and connected to the CSS. In order for the system to be automatically activated, these 5 sensors would need to stop sensing the user’s

vibrations/movements, and after a 3 seconds long alarm, the CCS would order the float to inflate.

Not sensing these vibrations/movements would mean that the user experienced some kind of trouble and is now unconscious. On the other hand, assuming the user was just extremely still, he/she would have that 3 seconds advantage to push any of the two shoulder buttons in order to cancel the automatic activation order.

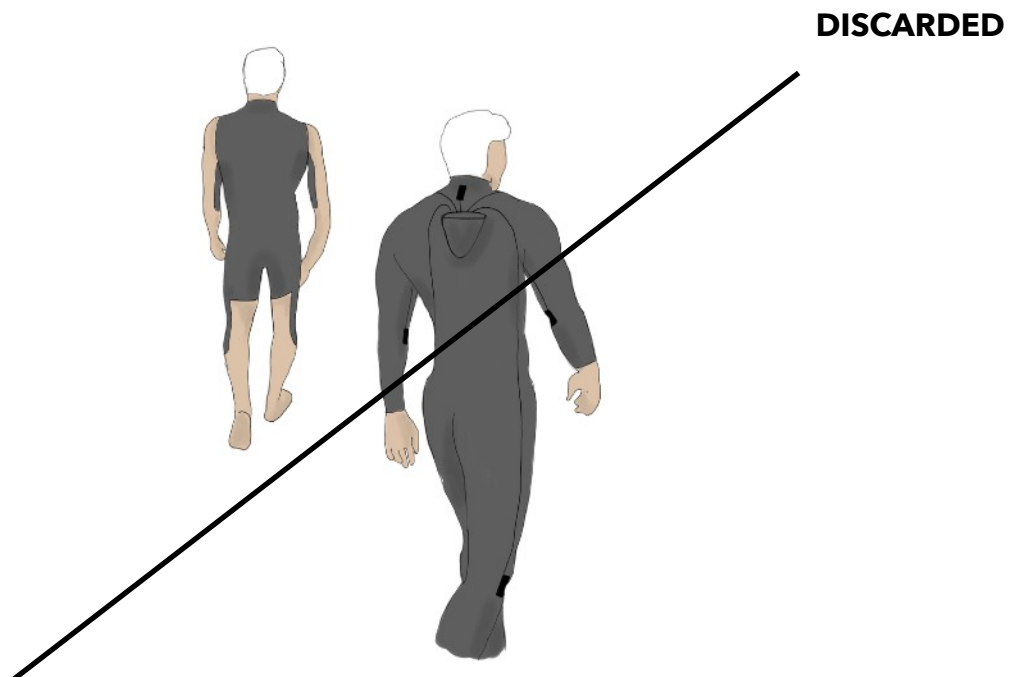

Sketch 1.8.2.8- Movement /pressure sensors

If this order was cancelled, the system would recognize that the user is fine, and after 30 seconds, all 5 sensors would be re-activated; the system would continue working as it originally was.

However, this option would not be completely safe due to the chosen technology, for:

- If the user were drowning, he/she could still be moving, causing contact with the sensors.
- If it were caused by a knock, when falling down to the water bottom, the user's posture could potentially cause one of the sensors to still be in contact. Por tanto, no resultaría una solución muy fiable para la automatización de este producto. Therefore, this solution would not be reliable for this product's automation.

1.8.2.9 Variations and final decision:

Finally, the final alternative was elaborated, and it goes as follows:

A type of sport assistant would be tried to be developed. In order to be better understood, a type of Siri (IOS) or Alexa (Amazon) that following some predefined guidelines, would determine whether the user is experiencing a dangerous situation or not.

As it has been said before, the system could be manually activated by pushing two buttons. However, the relevance of this project consists on automatically determining whether the user is drowning, unconscious or in any other dangerous situation.

From all the previous options, unconsciousness is going to be the main objective of this sport assistant, and it will be named Ariel.

This unisex name pretends (The little mermaid - female or Musician Ariel Rot - male) to put an end to this habit of relating the word "assistant" with a female image, which is how many different companies have done it so far: Siri (Apple), Alexa (Amazon), Cortana (Windows), Aura (Telefónica), Irene (Renfe) and Sara (Correos). At the same time, it will have a neutral-tone voice, that is, an equal voice.

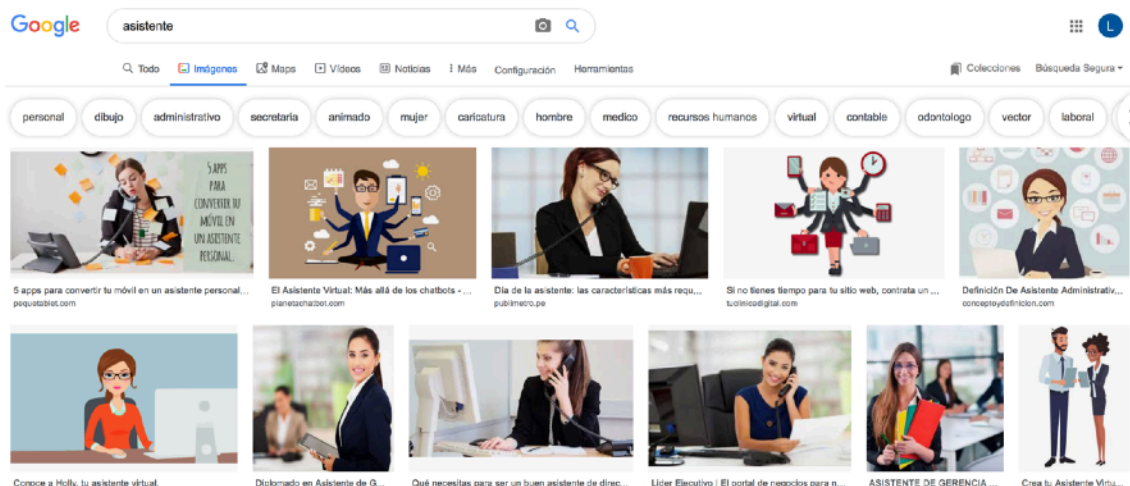

Image 1.8.2.9.1 -"Asiistant" on GOOGLE

But, how would Ariel determine whether the user is unconscious or not?. Well, Ariel would need to follow the Glasgow test:



GLASGOW COMA SCALE		
EYE OPENING	VERBAL RESPONSE	MOTOR RESPONSE
		
Spontaneous > 4	Orientated > 5	Obey commands > 6
To sound > 3	Confused > 4	Localising > 5
To pressure > 2	Words > 3	Normal flexion > 4
None > 1	Sounds > 2	Abnormal flexion > 3
	None > 1	Extension > 2
		None > 1
GLASGOW COMA SCALE SCORE		
Mild 13-15	Moderate 9-12	Severe 3-8
MEDIC*TESTS #1 EMT & PARAMEDIC EXAM PREP		

Image 1.8.2.9.2 -GLASGOW scale

Best Eye Response

- Not assessable (Trauma, edema, etc) (C)
- 4 Eyes open spontaneously. +4
- 3 Eye opening to verbal command. +3
- 2 Eye opening to pain. +2
- 1 No eye opening. +1

Best Verbal Response

- Intubated. (T)
- 5 Oriented. +5
- 4 Confused. +4
- 3 Inappropriate words. +3
- 1 No verbal response. +1
- 2 Incomprehensible sounds. +2

Best Motor Response

- 6 Obeys commands. +6
- 5 Localizes pain. +5
- 4 Withdrawal from pain. +4
- 3 Flexion to pain. +3
- 2 Extension to pain. +2
- 1 No motor response. +1

This test attempts to evaluate the level of consciousness of a person through three different values.

However, these values have been modified so they could be adapted to the possible situations in which a user could find itself (practicing a sport).

For the verbal response, Ariel would ask: "Are you okay?", question to which the user would answer OKAY if he/she was fine. If that wasn't the case, the assessment would be:

1. There is no response
2. The user answers some other words but "OKAY"
3. The response is "OKAY"

The handicap of this parameter is that, if the user were under water, he/she would not be able to answer, but at the same time he/she could be in a dangerous situation.

On the other side, for the motion response, Ariel would ask a second question, trying to obtain a physical gesture from the user as an answer. That is, Ariel would ask; "can you push one or two of the buttons?", and depending on the user's answer:

1. The user pushes no button
2. The user pushes one or both buttons

In this case, the problem would be if the sport the user is practicing requires both hands at the same time, and it might be the case the user does not want to stop just to push the button.

That is the reason why these two possibilities were incorporated in the suit. In that case, the user could push the button if he/she were not able to talk, or even say "OKAY" in case both hands were busy at that time.

For the vision part, the idea would be to incorporate a mini camera in one of the user's shoulders that is facing its face. An interface would need to be incorporated, and this interface would need to be capable of recognizing the location of the eye that is being observed, whether this eye is opened or not, and whether that eye is pointing the camera or not. Ariel would ask the user if he/she could look towards the camera, obtaining the following possible outcomes:

1. The user's eyes are closed.
2. The user's eyes are opened.
3. The user is looking towards the camera.

There is a chance the user cannot rotate its head and look towards the camera at that moment, because he/she finds itself in a critical point of its sport practice.

However, this option is out of the scope of this study, for it consists of a fairly complex system. It would require a camera with its corresponding interface that could capture the user's eye position, and identify whether this eye was open, closed or looking towards the camera; therefore, it will not be considered for the realization of this design during this project. Nevertheless, it will be taken in consideration for later improved versions in which new parameter for measuring the level of consciousness of the user want to be added.

Having said that, this project will be moving forward with the voice and motion parameters, in order to establish, in certain way, the level of consciousness of the user, and whether he/she is fine.

The user must push the buttons or say "OKAY" in order to prevent the system from deciding to inflate the float.



Sketch1.8.2.9.3 -Voice and motor check

Therefore, the Glasgow scale gets reduced to 5 levels, from value 2 to value 6. That is, there are 10 possible combinations of answers.

1. The user pushes no button (+1)
2. The user pushes one or both button. (+3)
3. There is no response (+1)
4. The user answers some other words but "OKAY" (+2)
5. The response is "OKAY" (+3)

If the user obtained a result 2 or 3, both, the system would automatically inflate the float. On the other hand, if the result were in between 4 or 6, it would continue operating and monitoring the user in a regular manner.

The user has to push the buttons (one or tow) or say "Okay" to don not allow the system start to inflate the float.

In order to make this happen, Ariel was thought to be located at the user's back device, and it would ask its questions through a speaker, but the real solution showed up when thinking about what to measure in order to make Ariel start asking those questions to the user.

Since using a pulse-oximeter had already been studied, and knowing that it can also be located at the earlobe, this would solve two different problems at a time, for the solution would be:

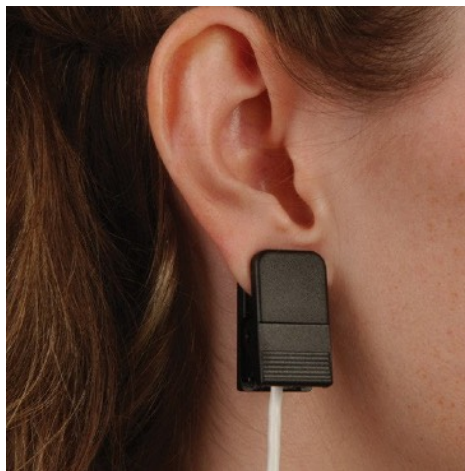

Image 1.8.2.9.4 -Oximeter on the ear

Placing a device in one of the user's ears; this device would permanently press the earlobe (as if it were a pressure earring) and it would constantly measure the user's pulse and its level of blood oxygen saturation. If at any moment, any of these two parameters decreased to abnormal levels, Ariel would start asking the questions to the user.

As it is detailed explained in Appendix 2.13 - Oximetry - Page ---, once the user's percentage of blood oxygen saturation falls under 95%, he/she would need immediate help, for it would not be receiving enough oxygen. For these cases, it would be taken for granted that the user is under water, and therefore, he/she is running out of oxygen. Once these values fall under 95%, Ariel will ask two recognition questions to the user, in order to make sure he/she is fine or not.

Response according to % of saturation	
% of Saturation	Response
> 95 %	Not immediate response needed.
95-90 %	Immediate treatment and patient's response monitoring. Depending on this response, consider transporting to hospital. Patients with chronic respiratory conditions can properly tolerate these levels of saturation.
< 90 %	Seriously ill. Severe hypoxia. Oxygen therapy + treatment and transport to hospital.
< 80 %	Consider intubation and mechanical ventilations.
Children with < 92%: Transport to hospital even if their condition improves with initial maneuvers; their treatment response can be uncertain.	

Image 1.8.2.9.5 - Oximetry

Regarding the pulse: Make sure there are no abnormalities in this parameter, that is, aggressive ups or downs in the user's pulse. The pulsometer could detect:

- An atrial fibrillation, which is when pulse goes up to 600 beats per minute.
- Ventricular fibrillation, which is when the ventricles are beating in a disorganized way (it could be caused by a heart attack).

It is important to consider that a competition can cause the heartbeat to exceed 100 beats per minute, but greater values could be related with dangerous physical efforts or even cause worse complications.

A different method to study the user's situations was thought. Just the same way a hook ammeter can measure a circuit's amperage by placing it around the cable, the possibility of designing a bigger kind of ammeter that could be placed around the suit's neck was investigated. This ammeter would measure the user's equivalent amperage, so in case he/she went unconscious for any reason, the number of pulses would decrease, and this would represent an alert to indicate something is wrong with the user.

However, this option was disregarded, for after a huge information research, it was observed that the measuring techniques for these impulses still have some problems to be dealt with; for example, our body's impulses are in the range on nanoamperes, which means that in order to be detected, they would need to be measured by electrodes added in the skull zone.

And the last study factor to be considered, was to place a conventional earbud in the user's ear.

Advantage: better understanding of Ariel.

Disadvantage: Less comfortable for the user. It would need to be fully waterproof.

Or through bone-conduction handset (Explanation on **Appendix 2.14** - Bone conduction - Page: 122.

Advantage: It is not as annoying to the user, for he/she has nothing inside its ear, and the possibility of losing the earbud due to normal user movements would be avoided.

Disadvantage: The sound is not as sharp as the one provided by a conventional earbud. It would need to be fully waterproof.

Finally, in order to provide a higher level of comfort to the user, and considering it will carry a heavier weight than a normal neoprene suit would represent, the bone conduction option was chosen.

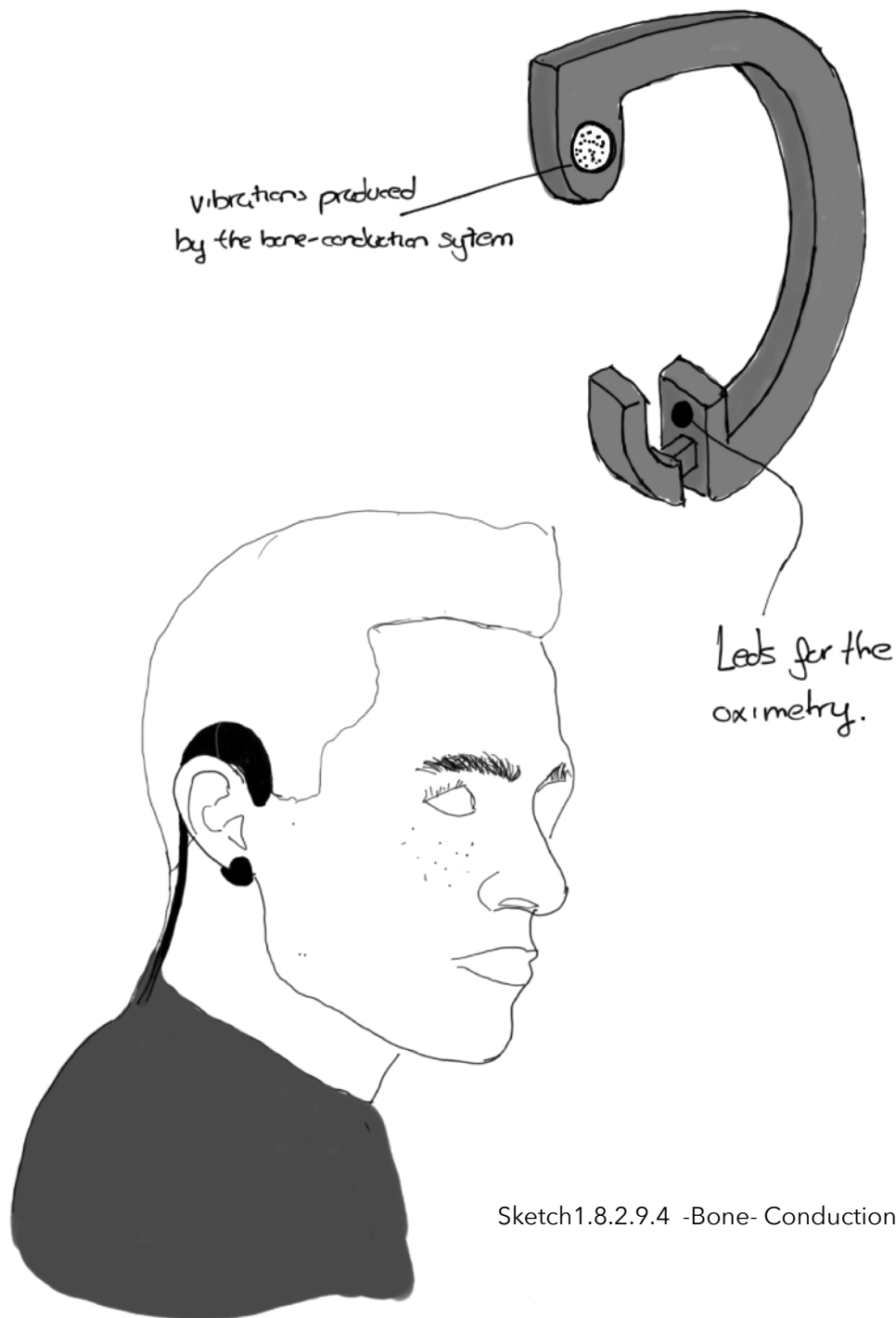

Sketch1.8.2.9.4 -Bone- Conduction system

It needs to be considered that, all the previously chosen systems (in a future the camera with its interface capable of recognizing the eye location, Ariel interface, bone conduction...) as the way to calculate the level of consciousness of the user, would need a much more extensive level of study than the one executed in this very one. All this fields will be externally studied in order to come up with a general solution to the main objective of this Final Degree Project.

When creating the blueprints, the mold of an ear was gotten for the blender format. This mold allowed some research on the dimensions and possible placements of the different parts of the earbud, propitiating the most comfortable and ergonomic result possible for the user.

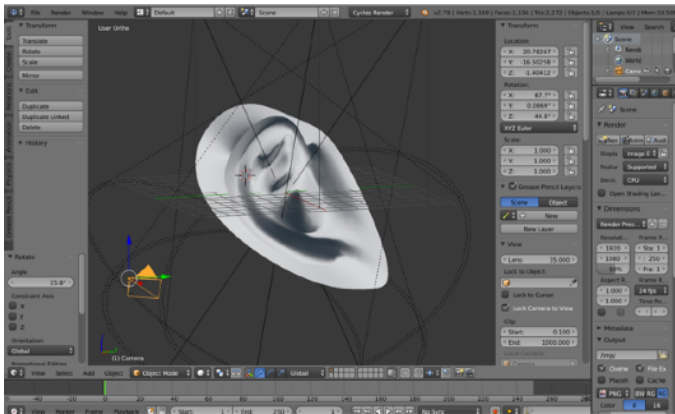

Image 1.8.2.9.5 -Ear



Sketch 1.8.2.9.6 -Ear sketch



Image 1.8.2.9.7 -Earbud modeling

This design considered manufacturing the earbud with different parts, so it could be modified and adapt to as many ears as possible. The image on the left shows the different earbud's parts by colors. The white pieces are:

- Bottom part: led diodes for the pulse-oximeter
- Top part: the device that emits vibrations to the user through its bones.

With all the changes executed in the final design, it was decided to make a DATUM comparison between the initial chosen alternative, and the one created after all the changes.

	Neoprene Suit	Neoprene Suit after changes
Efficient	D	1
Discrete	A	-1
Ergonomic	T	1
Safe	U	1
Comfortable	M	1
Economic	-	-1
		2

- 7. It must not disturb the user while it is playing a sport or doing some other similar activity.	1
- 30. Accessible market price.	0
- 3. Lightweight.	0,25
- 6. Easy to put on and take off.	1
- 15. Small.	0,25
- 8. It should be intuitive when being put on or taken off.	1
- 29. Minimum maintenance required.	1
- 5. Durable.	1
- 9. It could be made out of recycled materials .	1
- 10. Efficient	1
TOTAL	<u>7,50</u>

Chart 1.8.2.9.8 - DATUM and PONDERATION

A better valuation was obtained than that of the initial alternative before all the changes.

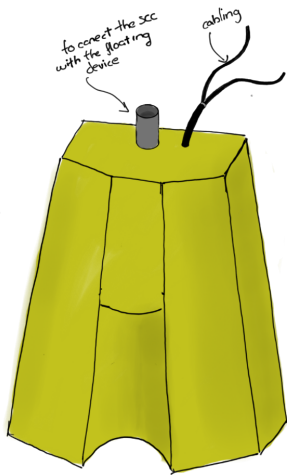
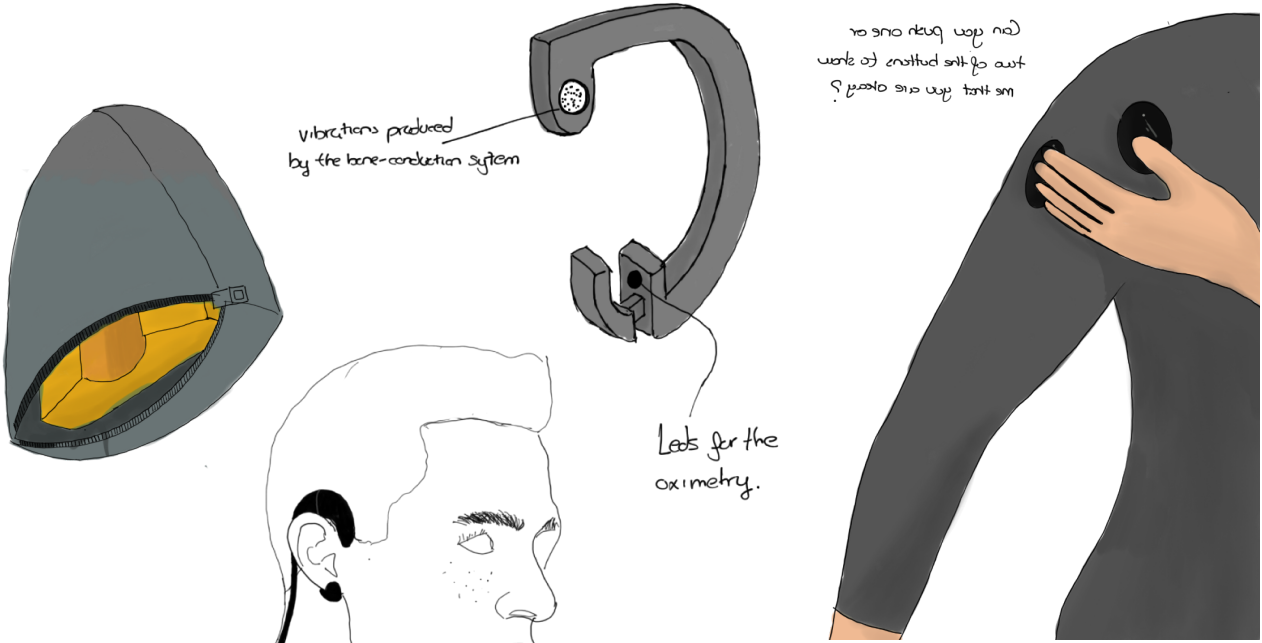

OKAY



male threaded tube adapter

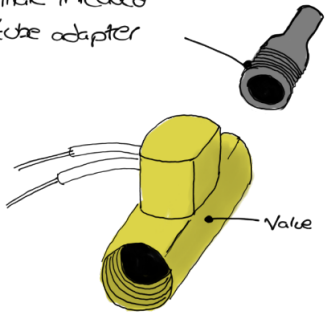

Study piece:
1: Introduce it in to the valve
2: Introduce CO₂ capsule opening a hole in it

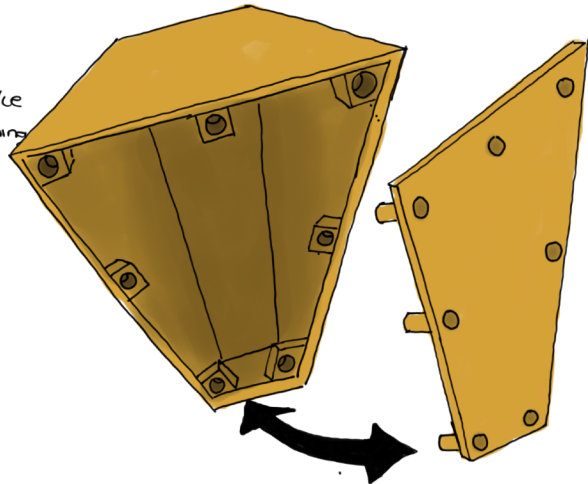
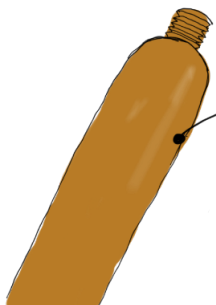

1.8.3 Materials:

All the components of this SCC design are intended to be manufactured with the same material, ABS. After comparing with other materials, ABS was selected due to its properties, manufacturing process, and results that could be obtained if this material was chosen. The selection of neoprene as the material for the aquatic suit is also mentioned. All this information is more completely and detailly explained in **Appendix 2.15** - Page 123 . And also in the **Appendix 2.16 - Material comparison** - Page 126 it can be found why it has be chosen ABS as material for this project.

PART	MATERIAL	REMARKS/ COMMENTS
1 - Suit	Neoprene	2 mm thick neoprene Extra elastic 2 mm thick neoprene 1 mm thick neoprene
2 - Device's case	ABS	Black NOVODUR ABS HH106 Pellet ABS
3 - Earbud's pieces (4)	ABS	Black NOVODUR ABS HH106 Pellet ABS
4 - Piece between CO ₂ capsule and the valve.	ABS	Black NOVODUR ABS HH106 Pellet ABS

Chart 1.8.3.1- Selected materials

Obviously it will be also needed the material to join this materials, for example:

-Termoadhesive

-Zippers and rack zippers

-Velcro

-Thread

-Glue

1.8.4 Manufacturing processes:

This section will cover the different manufacturing processes that will be used.

Neoprene suit: 1 - cutting of the neoprene pieces. 2 - Sewing. 3 - sealing of the seams.



Image1.8.3.2- Neoprene suit manufacturing

Device's case (two pieces) , the piece between valves and the four pieces of the earbud: injection mold.

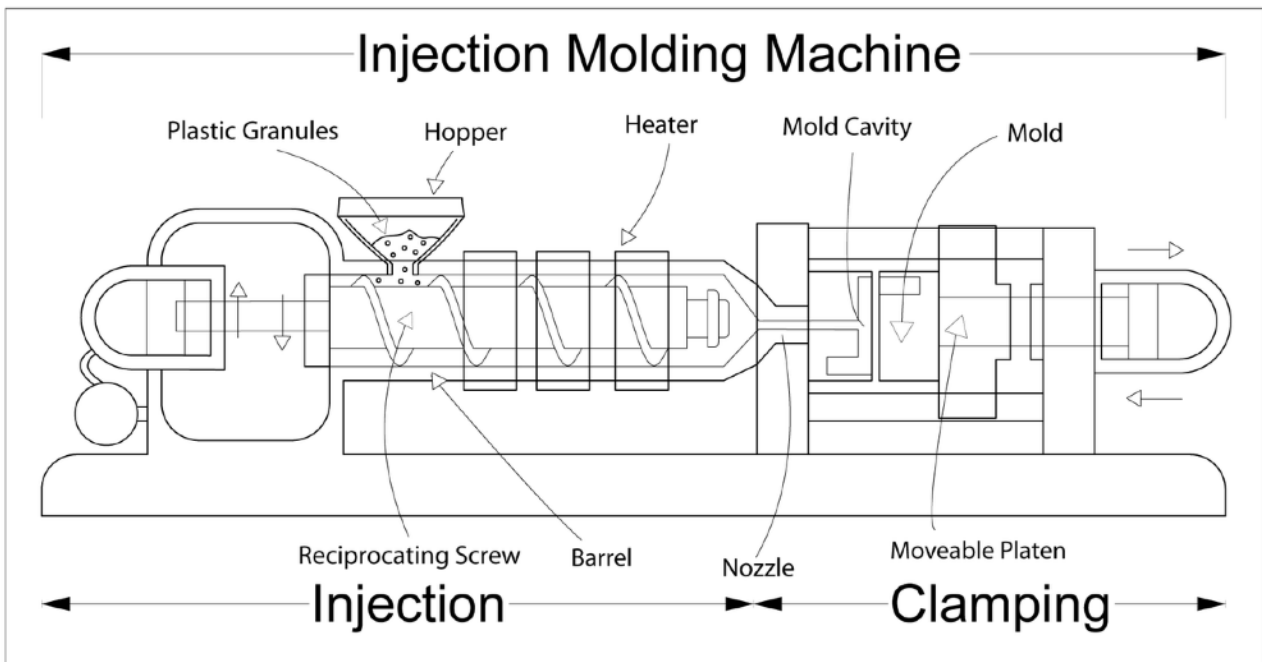

Image1.8.3.3- Process of injection mold

Plastic injection molding: It is a semi-continuous process that consists on the following:

The broken polymer, pellet, is placed in an upper funnel in the injection molding machine. The required amount of material is introduced in the cylinder. It then travels to the hot chamber, where the thermoplastic becomes a viscous liquid. Due to pressure effects, the liquid is passed to the mold, where the cavity gets completely filled up. The mold cools down while the pressure is sustained, and that is how the material acquires the desired shape. The final part is obtained by opening the mold and taking it out the cavity.

Very versatile parts can be obtained, rapidly manufactured parts, very complex geometries that would be impossible to get using other techniques can be easily manufactured. It does not require finishing operations. Very complex parts with considerably restricted tolerances can be obtained. The tooling cost is extremely high, so it is convenient to use it for large batches. This project will try to manufacture enough parts in order to justify the convenience of the tooling cost.

1.8.5 Assembly description

This section will show a step-by-step process on how the product will be completely assembled. It is assumed that the required machinery and materials are already available, and that the manufacturing processes required to create the three injection molding pieces have already been executed.

NUMBER	PIECE	STEP
1	Neoprene suit	Trim pieces
2	Neoprene suit	Add zippers
3	Neoprene suit	Añadir velcro-type strips

NUMBER	PIECE	STEP
4	Neoprene suit	Sew pieces
5	Neoprene suit	Seal all seams
6	Float	Sew to neoprene
7	Arduino	Add elements: - C-type port - Microphone - Wiring
8	Electro-valve	Introduce the fabricated piece
9	Touch sensor	Put in the correct position. She it to the neoprene suit. -And connect the wire to it.
10	Earbud	Connect the 4 pieces with the wire
11	Case	Add: -Arduino (with components) -Battery receiver -Battery -Valve -Wiring (sensor and earbud) - Male threaded tube adapter - Conect the boat tube to the male tube adapter
12	Neoprene suit	Sew and seal both neoprene layers.

Chart 1.8.5.1- Assembly description

1.8.5.1 Disassembly;

This brief section will explain how to disassemble and store the suit once the user has finished using it.

First of all, make sure the product is completely dry in order to avoid humidity. After that, fold both legs towards the body trunk, and then the arms to the inside. Finally, fold the body trunk so the upper back part ends up being the last layer; this facilitates access to the back pocket in case the battery needs to be re-charged, and it also optimizes space.

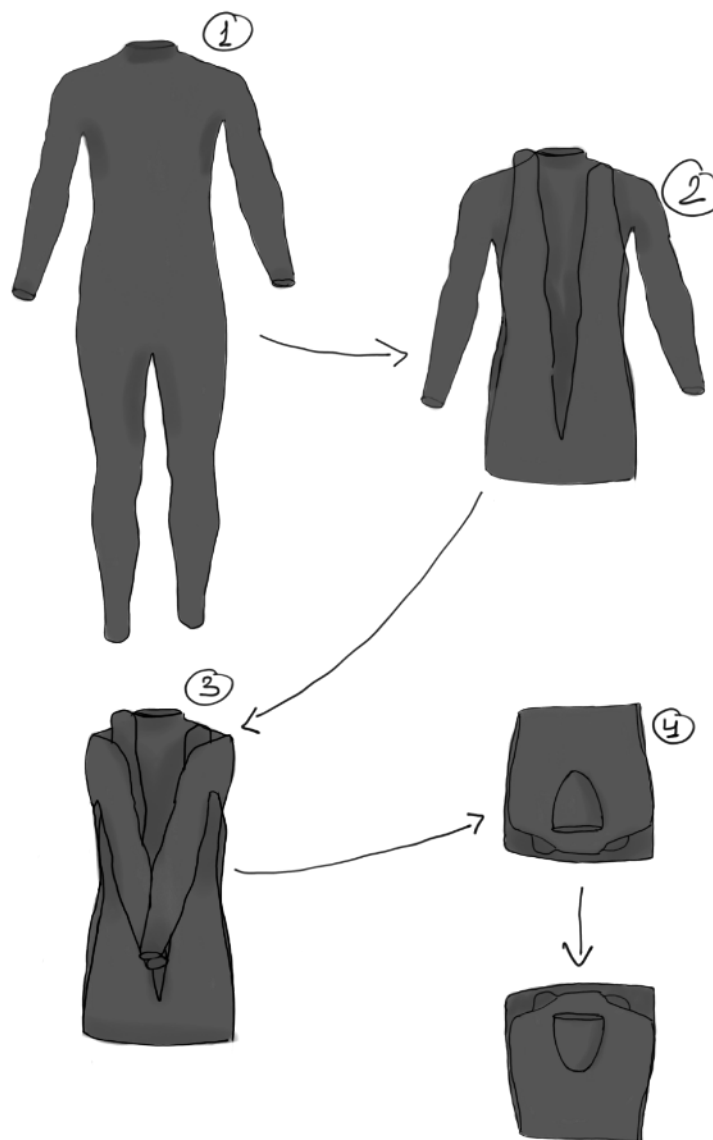

Sketch 1.8.5.1.1 - Disassembly process

1.8.6. Exploitation plan:

1.8.6.1 Brand image development;

Black, white and orange were chosen as corporate colors. This selection considers the colors used for the neoprene suit and the float (orange so it can be striking), and white so it distinguishes from the other two colors.

For name, the sound emitted when something or someone falls under water; Its possible variations are PLOF, BLOP and PLOP.

PLOF

BLOP

PLOP

BLOP

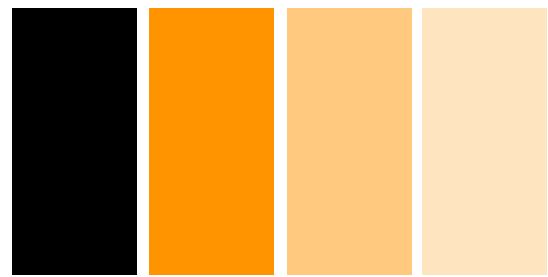

PLOP

PLOP

PLOP

Image1.8.6.1.1 - Brand development

Final Design:



Image1.8.6.1.2 - Final design

Orange:

R: 220

G: 120

B: 20

The "P" falling represents an object falling into the water. The black background was thought for when the logo is placed on the neoprene suit, and the orange background on the CCS at the back.

1.8.6.2 Packaging;

The product presentation considered some of the pre-established objectives, for instance:

- Use as few resources as possible
- Use recycled materials
- Simple manufacturing process. In this case, simple assembly process too.

Therefore, cardboard was chosen as the packing material. It will have a rectangular shape so when the product is folded as explained in section **1.8.5.1 Disassembly**, it perfectly adapts to these dimensions.



Image1.8.6.2.1 - Packaging with the logo

Dimensions:

44 X 31 X 13 cm

It was decided to use cardboard as the packaging material. It will have rectangular shape so, when the product is folded as explained in section 1.8.5.1 Disassembly, it perfectly adapts to these dimensions.



Image1.8.6.2.2 - Neoprene suit with the logo

1.8.7. Planification:

1.8.7.1 Times calculation

In the first place, in order to create a program that estimates the time it takes to produce a batch of 250 pieces, research on how long each procedure can take was made.

Determining the time it takes to produce 250 units, based on the time it takes to produce 1. This result was converted to hours, and then divided by 8, being 8 the number of hours in a workday. All these data finally allowed the Gantt diagram creation:

The break down of these calculations can be found in **Appendix 2.18** - Times' calculations, page: 132.

Neoprene suit creation: Cutting, sewing, sealing = 8 hours per day

250 pieces \rightarrow 250 days

Considering there is only one worker available for this task.

Parts to be manufactured: All parts would take 72 seconds

Batch of 250 parts \rightarrow 8,75 hours

Assembly: A suit's parts assembly process would take 3 minutes (SCC) + 110 seconds (Touch sensor) + 144 seconds (Earbud) = 434 seconds = 7,23 minutes.

Batch of 250 pieces \rightarrow 1808,33 minutes = 30,14 hours = 3,76 days of work (4 days).

The Gantt Diagram with the times required to create a batch of 250 suits can be found down below.

1.8.7.2. Gantt diagram

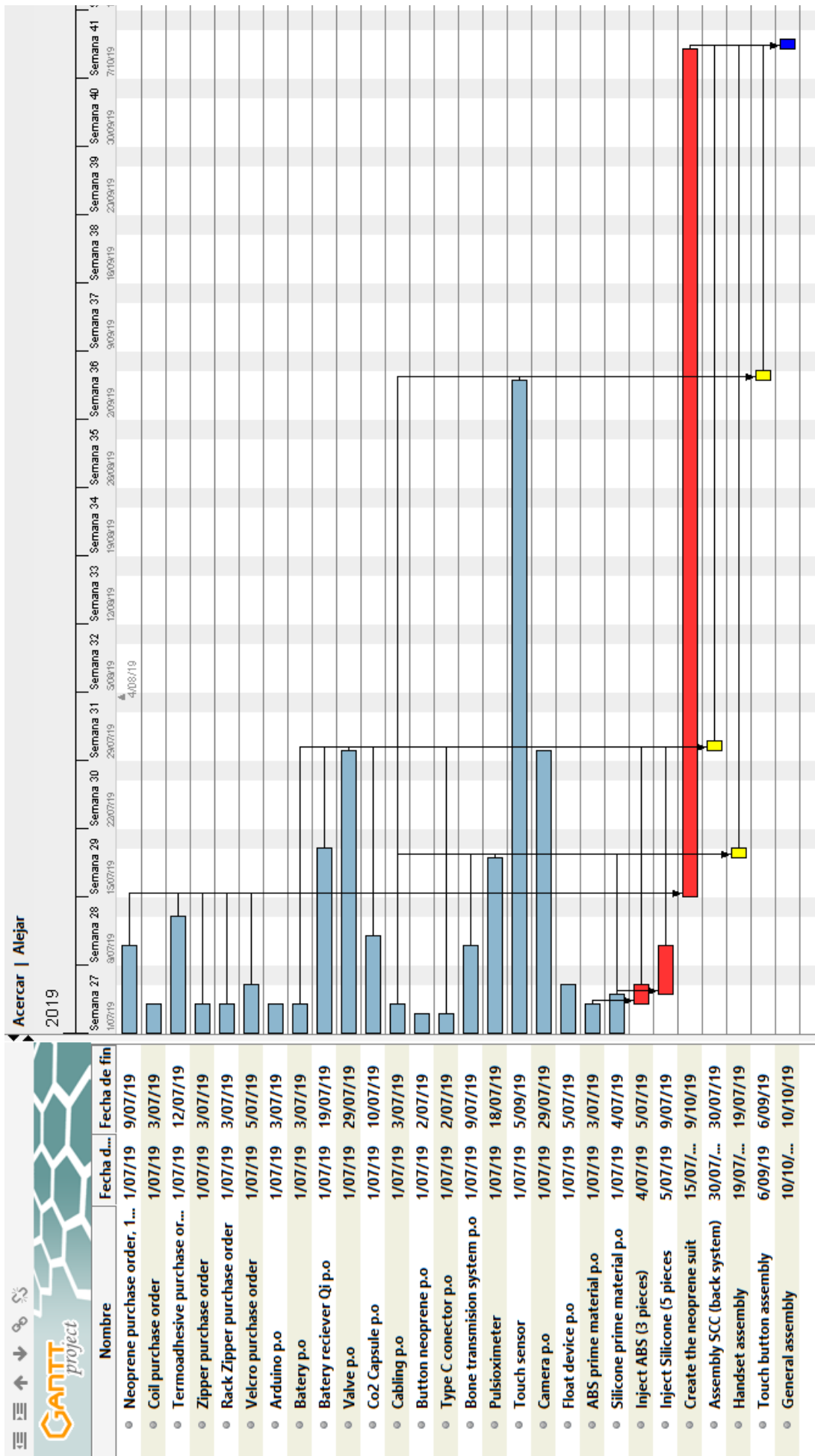

1.8.8 Economic study

In the project's section *Budget*, a detailed "costs and viability" study can be found. This section will only show the different costs of the project, as well as the final retail price.

Considering the workforce, raw materials, purchased parts and manufacturing costs, the final cost of the product is that of 173,4 €; this cost need to be added the following costs.

	Price
Indirect cost (10%)	17,34 €
Industrial cost (direct + indirect)	190,74 €
Commercialization const (15%)	28,61 €
Comercial Cost	219,351 €
Benefit (30%)	65,80 €
PVP (without IVA)	285,15 €
PVP (with IVA 21%)	345 €

The final market price is 345 €. This price is very competitive if compared with the different types of neoprene suits that can be found in the market. Moreover, its safety features and innovative design represent great competitive advantages.

2. APPENDIXS



Appendix' s Index

Appendix 2.1 - Precedents.....	79
Appendix 2.2 - Webs	83
Appendix 2.3 - Survey.....	86
Appendix 2.4 - Ponderation	88
Appendix 2.5 - Neoprene suit thickness.....	91
Appendix 2.6 - Wetsuit access system.....	93
Appendix 2.7 - Different joint systems.....	95
Appendix 2.8 - PFD'S elevation force.....	96
Appendix 2.9 - Calculation.....	100
Appendix 2.10 - Charged battery.....	108
Appendix 2.11 - Different posible gas.....	112
Appendix 2.12 - Valve.....	113
Appendix 2.13 - Oxiometry	118
Appendix 2.14- Bone conduction.....	122
Appendix 2.15 - Material.....	123
Appendix 2.16 - Material comparison.....	126
Appendix 2.17 - Patents	128
Appendix 2.18 - Time Calculation	132
Appendix 2.19 - Suplies.....	137
Appendix 2.20 -Emails with dealers.....	139
Appendix 2.21 - Molds cost.....	140

This second section will explain in detail all the information shown in the report that needs either further explanation, or complementary information in order to be better understood

Appendix 2.1 - Precedents:

Kingii



Operation and performance Kingii is a bracelet that allows its user to ascend up to the water surface in dangerous situations. It has to be manually operated. The user must move a lever that opens a compressed CO₂ capsule which pumps up the float, and the float takes the user to the surface.

Cost: 89,99\$ retail price

Blueprotect



Operation and performance The bracelet detects when the child plunges into water and sends a message that emits a loud alarm. It emits an alarm of 105 dB

Skybags



Operation and performance: Bag with a coating system to try to don't fall under the snow during a avalanche and GPS to find the user easily.

FLOATTOP



Operation and performance: Floating device for aquatic activities. This one it can be used only manually. There are other that with the contact with the water, the float start to inflate.

Cost: 79 €

Bidcom



Operation and performance : Bidcom is a bracelet for children and pets that it is activated when it is sunk in the water. The bracelet emit an alarm of 100 dB. It uses a 9V battery which lasts around 6-7 hours.

Cost199,99\$

WETSUIT O'Neil



Operation and performance

- Integral 5/4 mm
- Designed/recommended for water temperatures between 5 °C. and 17 °C.
- 100% Technobutter
- GBS sewn and glued seams

Cost: 200,00 €

FLOATING DEVICE



Operation and performance

275 N, Manual, no-harness PILOT PLASTIMO (EN399)

Once the device is inflated, the air chamber lights up in a yellow fluorescent color using reflecting bands.

The "clip" system keeps the floating device's neck adjusted to the user's dorsal area of its shoulders.

Weight: 1,12 kg

Cost: more than 50€

FOAM DEVICE



Operation and performance

Neoprene lifejacket - Professional Floating Device (PFD) with 2 buckles

Materials: Neoprene + Soft nylon

Filling: buoyant cotton

Cost: 49,1 €

BONE CONDUCTION



Operation and performance: The music, conversation whatever it can be listened through our bones. This happen when this sound is received by us through a vibration that our brain translate in sounds.

Cost: 20 - 180 €

EARBUD



Operation and performance : Listen music, start an conversation. It is a device that the users put in to the ears to have free their hands.

Cost: <60€

AMPERIMETER



Operation and performance

Neoprene lifejacket - Professional Floating Device (PFD) with 2 buckles

Materials: Neoprene + Soft nylon

Filling: buoyant cotton

Cost: 49,1 €

Appendix 2.2 - Webs:

Kigii	https://www.kingii.com/es/
Blueprotect	http://www.seguridaddepiscinas.es/alarmas/pulsera-antiahogo-blueprotect-para-ninos
Bidcom	http://bidcom.mercadoshops.com.ar/pulsera-antiahogo-seguridad-para-ninos-proteccion-al-agua-681xJM
Skybags	https://solonieue.es/reportajes/mochilas-airbag-nuestros-angeles-de-la-guarda/
Wetsuit	https://www.frussurf.com/traje-neopreno-oneill-youth-hyperfreak-comp-5-4-mm-161148-12.html
Float device	https://tiendanautica.lamarencalma.com/CHALECO-SALVAVIDAS-PILOT-275N-MANUAL
Orange color	https://aprendizajeyvida.com/2014/04/28/el-color-naranja/
Gas	http://bueno-saber.com/aficiones-juegos-y-juguetes/ciencia-y-naturaleza/potencia-de-elevacion-hidrogeno-vs-helio.php
Float Material	https://www.semirrigidasonline.com/a/dossier/los-tejidos-de-los-flotadores http://nauticol.es/es/module/smartblog/details?id_post=29 http://www.vanguardmarine.com/material-tecnologia/ https://www.semirrigidasonline.com/a/dossier/los-tejidos-de-los-flotadores
Pulsiometry	https://www.fisterra.com/material/tecnicas/pulsioximetria/pulsioximetria.pdf
Pulsioximeter	
GPS:	https://articulo.mercadolibre.cl/MLC-457163486-gps-mini-a8-rastreador-de-vehiculos-mascotas-y-personas-_JM?quantity=1 http://www.longbeachdive.com/recon-pro.html
Exclusion Calculator	http://calc.inclusivedesign toolkit.com
Flotability	https://www.portear.com/blog/la-flotabilidad-de-los-chalecos-desvelada/ https://securityalfa.wordpress.com/2018/04/18/chalecos-salvavidas-y-flotabilidad/ https://securityalfa.wordpress.com/2018/04/18/chalecos-salvavidas-y-flotabilidad/ https://www.portear.com/blog/la-flotabilidad-de-los-chalecos-desvelada/
Neoprene	http://espanol.alertdiver.com/Mojate_Bucea_Seco https://www.alltricks.es/F-46286-combinaisons-_-maillots-de-bain/P-806921-aquaman_dna_men_neoprene_wetsuit
Inalambric charge	https://www.belkin.com/es/resource-center/wireless-charging/how-it-works/ https://andro4all.com/2019/01/carga-inalambrica-que-es-moviles-compatibles https://www.20minutos.es/noticia/3155261/0/cargadores-inalambricos-llegan-quedarse-resonancia-inductivos/ https://www.elgrupoinformatico.com/que-carga-inalambrica-como-funciona-t72569.html https://andro4all.com/2019/01/carga-inalambrica-que-es-moviles-compatibles
Qi tecnología	https://www.yupcharge.com/es/blog/cargador-movil-wireless/ https://www.adslzone.net/2017/09/26/como-funciona-la-carga-inalambrica-qi-de-los-moviles/ https://www.elgrupoinformatico.com/que-carga-inalambrica-como-funciona-t72569.html https://www.ecured.cu/Qi_(estándar_de_electricidad_por_inducción)

Float device video	https://www.youtube.com/watch?v=qrjLskVoZjA https://www.youtube.com/watch?v=SnkrFRdxoOU https://www.youtube.com/watch?v=DCKA14AgkEw
Valve	https://www.burkert.es/es/type/0117 https://www.uml.co.uk/products.html# http://www.halkeyroberts.com/products/inflation/manualautomatic-inflators-new/alpha-automannual-inflator.aspx http://www.nauticexpo.es/prod/seacurity-gmbh/product-36835-325804.html#product-item_320022
Piezoeléctric	https://www.onestudiodesign.com/noticias/ahorra-con-tus-pisadas-nuevas-baldosas-que-generan-energia https://materialesinteligentes.win/piezoelectricos/ http://boletines.secv.es/upload/199534272.pdf
Electromagnets	http://comofunciona.org/que-es-y-como-funciona-un-electroiman/ https://explorable.com/es/construye-un-electroiman
Oximetry	http://www.lifebox.org/wp-content/uploads/WHO-Pulse-Oximetry-Training-Manual-Final-Spanish.pdf https://riunet.upv.es/bitstream/handle/10251/91753/LÓPEZ%20-%20Diseño%20e%20implementación%20de%20un%20pulsiox%C3%ADmetro.pdf?sequence=1 https://polaridad.es/monitorizacion-sensor-pulso-oximetro-frecuencia-cardiaca/
D hook	https://www.guardianfall.com/es/blog/gf-team-blog/214-harness-d-rings-and-fall-protection-applications http://s7d9.scene7.com/is/content/minesafetyappliances/2302-27-sp_ansi-updates https://safetysupply.com/wp-content/uploads/2015/05/ESP-Fall_UseGuide-2015.pdf https://multimedia.3m.com/mws/media/1416107O/ifu-5903805-exofit-strata-harness-sp-l.pdf
Water Temperature	https://www.omio.es/blog/mejores-playas-surf-europa/ http://es.surf-forecast.com/breaks/Lagundri-The-Point/seatemp1 https://es.weatherspark.com/y/144661/Clima-promedio-en-Costa-Dorada-Australia-durante-todo-el-año http://es.surf-forecast.com/breaks/Zarautz/seatemp
Wet OR dry SUIT	https://www.spotmydive.com/es/news/como-elegir-su-traje-de-buceo-humedo-o-seco http://espanol.alertdiver.com/Mojate_Bucea_Seco
Neoprene fabrication video	https://www.artsurfcamp.com/blog/sabes-como-se-fabrican-los-trajes-de-neopreno/
Joints	https://www.artsurfcamp.com/aprender-surf/datos-y-caracteristicas-del-traje-de-neopreno
Neoprene weight	https://www.artsurfcamp.com/aprender-surf/datos-y-caracteristicas-del-traje-de-neopreno https://www.quiksilver.es/grosor-neoprenos/
Neoprene suit materials	https://surfingshow.wordpress.com/2011/04/04/como-elegir-traje-de-neopreno-construccion-material-y-tallas/ http://www.escueladesurflaislasantamarina.es/trajes-de-surf/ https://www.mundo-surf.com/blog/elegir-traje-de-neopreno-surf-bodyboard/ https://www.reviewbox.com.mx/traje-de-neopreno/
Gas potential	https://www.usroasterie.com/potencia-elevacion-helio-y-hidrogeno.html
Salt pills	https://nautic-market.com/chaleco-automatico-halkey-roberts

Coils	https://spanish.alibaba.com/g/qi-wireless-charging-coil.html https://articulo.mercadolibre.com.mx/MLM-653114212-3-bobina-qi-cargador-inalambrico-circuito-pcba-cargador-bob-_JM?quantity=1
Lifejackets	https://www.nauticayyates.com/equipo/salvavidas-hinchables-lo-saber/ https://www.elcorreo.com/planes/playas/bizkaia/laidatxu-mundaka-0000447.html
Materiasl	https://www.budind.com/view/Plastic+Boxes/Hand-Held+Grabber+Style+O https://www.digikey.com/products/es/rf-if-and-rfid/rf-antennas/875 https://www.mouse.com/?gclid=Cj0KCCQjw9pDpBRCKARIsAOzRzisX6fJbmgYrP7gXSe8tL3xrimAOSr3l8P3JNXuWRoP7RcZt321ms2ElaAgbAEALw_wcB https://www.phoenixcontact.com/online/portal/pi?1dmy&urile=wcm:path:/pies/web/home https://www.phoenixcontact.com/online/portal/pi?1dmy&urile=wcm%3apath%3a/pies/web/main/products/subcategory_pages/Electronics_housings_P-01/bf184df7-b458-487a-81f6-a86ac6c22e9d https://www.sumidelec.com/senalizador-luminoso-baliza-led-81801-niessen-p-8645
Lifejackets light	https://www.lifejackets.co.uk/products/687/crewsaver-lifejacket-lights-half-price
CO₂ Capsule	http://spanish.maritimesafetyequipment.com/sale-7593838-16g-24g-33g-60g-co2-cylinder-co2-carriage-for-inflatable-life-jacket-with-1-2-thread.html
ABS	https://es.wikipedia.org/wiki/Acrilonitrilo_butadieno_estireno https://blog.reparacion-vehiculos.es/plastico-abs-resistente-ligero-moldeable http://www.plastico.com/temas/Estudiantes-desarrollan-tecnologia-para-reciclar-ABS-y-PLA+116582
Glasgow	https://legacy.medictests.com/gcscoring/
Ear Model	https://free3d.com/es/modelo-3d/ear-78132.html
Pulso	http://www.igerontologico.com/salud/cardiologia-salud/arritmias-cardiacas-6582.htm https://empendium.com/manualmibe/chapter/B34.I.1.35.

Chart 2.2.1 - Webs

Appendix 2.3 - Surveys:

The survey consisted on face-to-face interviews, for there were 10 available people on-site who had a clear idea on this project's topic and, therefore, were able to share their opinion on what they thought was more important for a potential user. Disregarding the restrictions, wishes, and similar-to-each-other objectives, the respondents were asked to select from the 24 remaining objectives, the top ten most important ones for them. The following section shows right next to each objective, the number of times it was chosen as one of the most important ones by the respondents.

Designer objectives:

3. Lightweight. **10**
4. Resistant G. **3**
5. Durable. **9**
6. Easy to put on and take off. **10**
7. It must not disturb the user while it is playing a sport or doing some other similar activity. **10**
8. It should be intuitive when being put on or taken off. **9**
9. It could be made out of recycled materials. **7**
10. Efficient. **7**
11. Easy to store. **2**
15. Small. **10**

Manufacturing objects:

17. As easy as possible **0**
18. Easy-to-handle materials.
22. Easy-to-assemble product. **0**
24. Requires very few resources to be produced. **1**
25. Very little contamination. **1**
27. As short as possible. **0**

- 28. As cheap as possible. **0**
- 29. Minimum maintenance required. **8**

Post-manufacturing object:

- 30. Accessible market price. **9**
- 31. As attractive as possible. **1**
- 32. As many sales as possible. **0**
- 33. Easy to transport. **1**
- 34. Satisfy user’s expectations. **2**

The ten objectives that were evidently more valued by the respondents are the ones that will be later used for the objectives-weighting study, same that is shown in the next page.

The following table lists the names of the respondents, all of which previously authorized being mentioned in this project.

Surveyed names
Celia Wu-hacoben
Bronwyn Chochinov
Callum Galloway
Jesús Eduardo Tostado Nieto
Sarah Barrey
Lluís Peris Miralles
David Fowler
Elizabeth Teklu
Cecilia Cipullo
Haywood Schwartz

Chart 2.3.1- Surveyed names

Appendix 2.4 - Ponderation:

1st alternative: **PIFLOT**

- 7. It must not disturb the user while it is playing a sport or doing some other similar activity.	0
- 30. Accessible market price.	0,25
- 3. Lightweight.	0,25
- 6. Easy to put on and take off.	0,25
- 15. Small.	1
- 8. It should be intuitive when being put on or taken off.	1
- 29. Minimum maintenance required.	1
- 5. Durable.	0,25
- 9. It could be made out of recycled materials .	1
- 10. Efficient	0
TOTAL	<u>5</u>

Chart 2.3.4.1- 1st alternative

2nd alternativa: **GPG + SOS Bracelete**

- 7. It must not disturb the user while it is playing a sport or doing some other similar activity.	1
- 30. Accessible market price.	0,25
- 3. Lightweight.	1
- 6. Easy to put on and take off.	1
- 15. Small.	1
- 8. It should be intuitive when being put on or taken off.	1
- 29. Minimum maintenance required.	1
- 5. Durable.	0,25
- 9. It could be made out of recycled materials .	1
- 10. Efficient	0
TOTAL	<u>7,5</u>

Chart 2.3.4.2 - 2nd alternative

3rd alternativa: **Chest Float**

- 7. It must not disturb the user while it is playing a sport or doing some other similar activity.	0,25
- 30. Accessible market price.	0,25
- 3. Lightweight.	0
- 6. Easy to put on and take off.	0,25
- 15. Small.	0,25
- 8. It should be intuitive when being put on or taken off.	1
- 29. Minimum maintenance required.	1
- 5. Durable.	1
- 9. It could be made out of recycled materials .	1
- 10. Efficient	0,25
TOTAL	<u>5,25</u>

Chart 2.3.4.3 - 3rd alternative

4th alternativa: **Back float** - it obtains the same result than 3rd alternative.

5th alternative: **Neoprene Suit**

- 7. It must not disturb the user while it is playing a sport or doing some other similar activity.	1
- 30. Accessible market price.	0
- 3. Lightweight.	0
- 6. Easy to put on and take off.	1
- 15. Small.	0,25
- 8. It should be intuitive when being put on or taken off.	1
- 29. Minimum maintenance required.	1
- 5. Durable.	1
- 9. It could be made out of recycled materials .	1
- 10. Efficient	1
TOTAL	<u>7,25</u>

Chart 2.3.4.4 - 4th alternative

Chosen values for DATUM:

- Efficient: The object can rapidly pull the user up to the surface and put him/her out of a danger situation.
- Discrete: The product does not call other people's attention because of its shape, color or size.
- Ergonomic: The product adapts to the user's body shape, and it does not make him/her lose its equilibrium or change its center of mass' location.
- Safe: The object can pull the user up to the surface and put him/her out of a danger situation with a high success rate.
- Comfortable: The product is easily worn, and it does not bother the user while practicing its chosen sport.
- Economic: Estimated market cost for each alternative.

Appendix 2.5 - Neoprene suit thickness:

The thicker the suit, the better protection against cold it will provide. However, it will also be less comfortable, and it will hinder the user's free movement.

Neoprene suits are commonly manufactured by combining layers of different thicknesses. A greater thickness is used for those body parts that need to remain warm, that is, they need to avoid cold water by all means; these areas are the followings: chest, back and legs.

Since arms and shoulders need more mobility and flexibility, the neoprene layers' thickness is reduced in these areas in order to ease swimming and rowing movements.

In general, neoprene suits can be from 1 to 6 mm thick. This thickness varies depending the temperature of the water in which each suit is intended to be used.

The following **guide table** shows the optimal thickness for a neoprene suit, depending on the water temperature in which the user will be swimming.

Characteristics of the neoprene suit depending on the water T ^a in which it is intended to be used	
23°C or higher	<ul style="list-style-type: none">Bathing suit and shirt, or lycra
21°C to 23°C	<ul style="list-style-type: none">Bathing suit, and 1 mm or thicker neoprene overall
18°C to 21°C	<ul style="list-style-type: none">2 mm short suit
17°C to 18°C	<ul style="list-style-type: none">2 mm suit that could have short sleeves or short legs
14°C to 17°C	<ul style="list-style-type: none">3/2 mm long suit
12°C to 14°C	<ul style="list-style-type: none">3/2 mm or 4/3 mm suit with booties
10°C to 12°C	<ul style="list-style-type: none">4/3 mm long suit, with booties and neoprene gloves
8°C to 10°C	<ul style="list-style-type: none">5/4/3 mm long suit, with booties, neoprene gloves, and neoprene hat
8°C or lower	<ul style="list-style-type: none">6/5/4 mm long suit, with booties, neoprene gloves, and neoprene hat

Chart 2.5.1 - Water Temperature

In order to make sure which thickness would be more adequate, or which one would cause the greater amount of sales, research was made on the water temperature in some of the most important surfing destinations in Europe:

LOCATION	TEMPERATURE	RECOMENDATION
Praia do Nazaré, Portugal	14,1 - 16,3 °C Winter	–
Tarifa, Cadiz, Spain	15,5 - 17 °C Winter	3/2 mm of thickness
Reykjanes, Iceland	5,7 - 7,1 °C Winter	Great thickness, hat, gloves and booties
Las Landas, France	12 - 14 °C Winter	From 2 to 3/2mm
Lunan Bay, Montrose, Scotland	5 - 8 °C Winter / 13 - 16 °C Summer	From 4/3 to 5/3 mm
Zarautz, Spain	12 - 22 °C Winter - Summer	4/3 mm in Winter

Chart 2.5.2 - Water Temperature

The same research was extended to some of the most important surfing beaches all around the world:

LOCATION	TEMPERATURE	RECOMENDATION
Waimea beach, Hawaii, USA	19 - 30 °C Winter - Summer	–
Puerto Rico	15 - 26 °C Winter - Summer	–
Boni Beach, Australia	16 - 20 °C during Winter	From 3/2 to 4/3mm
Surfers Paradise, Australia	19 - 22 °C during Winter	From 2 to 3/2 mm
Costa dorada, Australia	10 °C Winter / 28 °C Summer	–

Chart 2.5.3 - Water Temperature

Now there is an idea of how cold temperatures in some surfing beaches around the world really are.

It is hard to pick just one thickness range, for water temperatures considerably vary depending on the part of the planet in which a beach is located.

However, this project will implement 1 mm (inside) + 2 mm (outside), causing the user to be protected by 2 mm of neoprene all around its body, and those areas that need extra heat (back and chest) will be covered by a 3 mm layer.

Appendix 2.6 - Wetsuit access system:

Zip closure: Its biggest disadvantage is that water might find its way through the zip, reducing both the suit's efficiency and its thermal insulation capacity. However, there are special zippers (developed for these specific purposes) that integrate both internal and external sealing strips in order to avoid this water-leaking problem.

Zippers can be placed in different areas of the wetsuit:

- Back Zip: this type of zip runs all along the upper and lower back, making it fairly easy for the user to both access or exit the suit by pulling a long strap that opens and closes the zip when necessary without a second person's help needed.

- Front Zip: This type of zip is located at the front part of the wetsuit.

Depending on the design, this zip can be positioned in different areas of the front upper body;

- Zip that runs from the neck down to the user's belly button.
- Half zip that runs from the neck to the lower chest area.
- Diagonal zipper, running from one side of the neck to the opposite side of the upper body area.
- Chest zipper: this design is significantly different to the rest of them. Arms and legs are supposed to be introduced into the wetsuit first, and both the neck and chest areas will somehow be behind the user's back after that. Then, the suit has to be stretched up so the user can introduce its head into the neck hole.

Neck system: The user access the suit through the neck hole. This access system is highly efficient when it comes to thermal insulation, but the fabric might suffer

permanent deformation in the long run due to the fact that it must be temporarily warped when putting the suit on. This kind of neoprene suit is higher quality and extremely flexible, but it is also significantly more expensive than the ones with zip closure.

After considering positive and negative aspects of both options, the zip closure system has been selected for the following reasons:

- Since the floating device will be located both around the neck and around the upper body, neoprene's elongation capacity might eventually decrease, making it fairly complicated for the user to get into the suit.
- Considering the electronic device will be located in the upper part of the suit's back, a zipper is the best option for the suit would not be unnecessarily elongated, and it would be easier for the user to both access and exit the wetsuit.

A izquierda tenemos el sistema Zip closure y a la derecha el Neck System.



Image 2.6.1 - Neoprene suit

Appendix 2.7 - Ways to join different parts of the wetsuit

This is a crucial factor to be taken in consideration for the suit's water-proof contain will basically depend on this. An extensive researching process on this specific topic has lead to three different kinds of joints that could be useful for this type of suit.

- Flatlock Stitching; Two different fabric pieces are joined together through both-sided stitching. This is the traditional technick, but nowadays it is barely used in modern wetsuit designs.
- Sealed; Different fabric peces arre sewed together in a way that stitches cannot be seen. After both pieces have been sewed, an special glue sealing paste is added all along the stitches line in order to give the suit the water-proof condition (almost).
- Sealed and Taped: This method is fairly similar to normal sealing, except that inside stitches are covered with special straps that prevent both rubbing and outside water getting into the suit.

Suit seal can be either a liquid kind of neoprene, or neoprene straps that are attached on top of the stitches lines. These straps can be placed on both the inside or the outside of the suit. Depending on the specific design purposes.

For instance, some companies seal only the most important parts of their suits, that is, those in which temperature must be kept from dropping and those in which water must no enter at any time. Not sealing even single stitch line reps decreasing the product's market price, for both raw materials an labor work can be optimized.

The most effective technick is "sealed and taped" (considering heat conservation as the effectiveness criteria), but it is also the most expensive one, for it requires more raw materials and labor work than the other two methods.

In order to determine an accurate price and a realistic time period this procedure could be executed in each suit, the following professional was contacted. Ana Martínez Iserte. She fully explained the exact sealing process that would be used for this specific design, the human hours that this process would require, as well as the cost of both labor work and required raw material.

Appendix 2.8 - PFD'S elevation force

There are several types of PFD's (Personal Flotation Devices) with different in-water performances depending on their primary purpose and the required safety standards for each purpose. These safety standards and different performance levels are specified and regulated by ISO Norm 12402, which is an standardized guideline for manufacturers, buyers and users of Personal Flotation Devices for both in-water or near water activities, and it is mainly used to guarantee PFD's reliability and adequate performance. Different PFD's are meant to fulfill the following regulated specifications depending on their required elevation capacity:

- Assisted flotation PFD's: Their buoyant force goes up to 50 N, but they are not considered actual lifejackets for they are meant to be used near an edge or as an assisting flotation device during water rescues, requiring at all times active participation of the user. Therefore, these kind of PFD's will not be appropriate for the proposed design, for an unconscious user that is not able to actively participate in its own rescue is one of the possible scenarios that this project is attempting to solve. Assisted flotation PFD's are regulated by Norm EN 12402-5.
- 100 N level PFD's: These kind of devices are required to have around 10.2 Kg of buoyancy (the physical meaning of buoyancy will be later explained), and they are able to buoy a 100 kg person with no swimming skills (no user's active participation needed). However, they are not able to keep a person facing up (head above water) if that person goes unconscious. Once again, these kind of PFD's are not appropriate for the proposed design. 100 N level PFD's are regulated by Norm EN 12402-4.

- 150 N level PFD's: These devices have a minimum buoyancy of 15 Kg, but more importantly, they are capable of flipping a person over and keep that person facing up when unconscious. However, one disadvantage of this type of PFD is that once it is inflated, its volume obstructs user's movement in case that person is not unconscious and is trying to move forward. This performance level is the most adequate for this project's purposes; nevertheless, the floating device could be located in a different position in order to simplify user's movement once the device is inflated. 150 N level PFD's are regulated by Norm EN 12402-3.
- 275 N level PFD's: These kind of devices are meant to be used in high sea navigation, where climate conditions could be extremely rough, and considering the user is wearing heavy clothes and a coat. However, once they are inflated, its massive volume makes user's movement practically impossible. 275 N level PFD's are regulated by Norm EN 12403-2.

The Kilogram quantities in the following table show the amount of mass that the corresponding PFD would be able to buoy, this considering the density of, for instance, gold, lead or iron, etc. Moreover, the force magnitude of each PFD (Newtons) represents their buoyancy force, which is the vertical force exerted on and object that is partially or completely submerged underwater.

In order to convert Newtons to force Kg, the first value needs to be multiplied times 0,1019.

The following table shows the result of this operation:

Conversion form Buoyancy force (N) to force Kilograms (Kg)	
50 N	5,10 Kg
100 N	10,2 Kg
150 N	15,3 Kg
275 N	28 Kg

Chart 2.8.1 - Buoyancy force

Considering a person whose mass is 120 Kg, approximately 80% of that body mass is actually composed by water. Since that person will be floating in the same liquid (water), that 80% can be neglected, for it adds no extra weight to what the PFD has to support.

This condition applies for non-salty water, that has an approximate density of 1000 kg/m³. However, the proposed design is also meant to be used in salty water, and due to the fact that this liquid has greater density (approximately 1027 kg/m³), the human body would actually be a little more buoyant in this fluid.

As a reference, all physical calculations will consider the least favorable fluid conditions, that is, buoyancy will be calculated using non-salty water properties.

Therefore, out of the 120 Kg of mass of the user, 96 kg would be water; amount that must not be considered for the calculations.

On the other hand, the human body is 15 to 20% composed by body fat, element that is naturally lighter than water; therefore, it should also not be considered for the required buoyancy force calculations.

However, this design is meant to be used by athletes, people who might actually have a lower percentage of bod fat than an average person; this is why all calculations will consider a body fat percentage of 10%, and this translates into 12 extra kilograms that will not be considered for the required buoyant force.

120 kg of mass - 96 kg of water (80%) - 12 kg of body fat = 12 kg of mass that must be supported by the floating device installed on the proposed design.

If these 12 kg of mass are converted into buoyant force (N) that must be exerted by the floating device of the design, this represents a magnitude of 118 N.

If average values were being considered for these calculations, the required buoyant force would be significantly different.

90 kg of mass of the user - 72 kg of water (80%) - 13.5 kg of body fat (15%) = 4.5 kg of mass that must be supported by the floating device of the proposed design.

However, knowing that the user's safety must be guaranteed, the least favorable calculation results are the ones that will be used for this design. Those results are obtained when considering an outlier user when it comes to physical characteristics.

Using all these previous data, the required floating device that this study will need it is a 150 N elevation force. It is known that with this level the user would have the face and chest outside of the water.

Also the floating device will keep the head above of the water. The head's weight is approximately around 8 Kg (also considering the neck) . The floating device with 150N of elevation force also consider that because to keep a body on the surface of the water the floating device must supported around 4.5 kg (part of this from the head, more or less 0,5 kg) If it is add to 4 kg $(4.5 - 0.5) + 8 \text{ kg} = 12\text{kg}$. And how it was explained before a floating device with a 118 N of elevation force can support 12 kg. So 150 N will be more than sufficient.

Appendix 2.9 - Calculation

The first calculation is made to know how thick has to be the back case:

In the next page it can be found the webpages where it was found the information to realize this calculation.

$$Ec = \frac{1}{2} \cdot m \cdot v^2 = 13,328 J$$

$$E = W$$

$$W = F \cdot dist$$

$$F = \frac{W}{Dist} = \frac{13,328}{1,7} = 7,84N$$

$$\sigma_{adm} = \frac{Sy}{ns} = \frac{44,1 MPa}{1,5} = 29,4Mpa$$

$$\sigma_{adm} \geq \sigma_{max}$$

$$\sigma_{max} = \frac{Mfmax}{I}$$

$$I = \frac{1}{12} \cdot b \cdot e^3$$

$$Mfmax = Mc = \frac{F \cdot L^2}{24} = \frac{7,84 \cdot 0,055^2}{24} = 9,881667 \cdot 10^{-4}$$

$$cuando x = \frac{L}{2}$$

For this calculation, it has been considered that the case falls to the floor from the user's back. It arrive to the floor with an Kinetic Energy of 19,328 J.

From that, it can be obtained the force that the object hit the floor.

For this case it has been assumed a safety coefficient of 1,5. And with that the yield strength. Finally with the inertia momentum formula it can be possible to isolate the thickness (e) and get a result.

The force with which it hits the ground is calculated first; considering the material's maximum admissible tension and the section profile's moment of inertia, the maximum thickness that would be capable of standing this impact is obtained.

$$e^3 = \frac{Mf_{max} \cdot 12}{\sigma_{max} \cdot b} = \frac{(9,88167 \cdot 10^{-4} \cdot 12)}{(29,4 \cdot 10^6) \cdot 0,11}$$

$$e = 1,542 \cdot 10^{-3} = 1,54 \text{ mm}$$

Image 2.9.1 - Calculation case thickness

Once 1,54 mm of thickness have been obtained, it was decided to manufacture the part with a thicker wall, that is, 3mm in order to provide more rigidity to the container. Doing the calculation process backwards, it would result in a force of 57,13N.

Fuerza de Impacto en la Caída de Objetos

Aunque incluso la [aplicación de la conservación de la energía](#) sobre un [objeto en caída](#), nos permite predecir su velocidad de impacto y su energía cinética, no podemos predecir su fuerza de impacto, sin conocer cuanto se desplaza después del impacto.

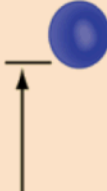

$E_p = mgh$
 $E_c = 0$

Si un objeto de masa $m = 0.8$ kg se deja caer desde una altura $h = 1.75$ m, entonces su velocidad justo antes del impacto es $v = 5.85662$ m/s. La energía cinética justo antes del impacto es igual a $E_c = 13.72$ J.

Image 2.9.1 - Ec calculation

<http://hyperphysics.phy-astr.gsu.edu/hbasees/flobi.html>

VIGA SIMPLE EMPOTRADA: carga uniforme q en todo el vano.

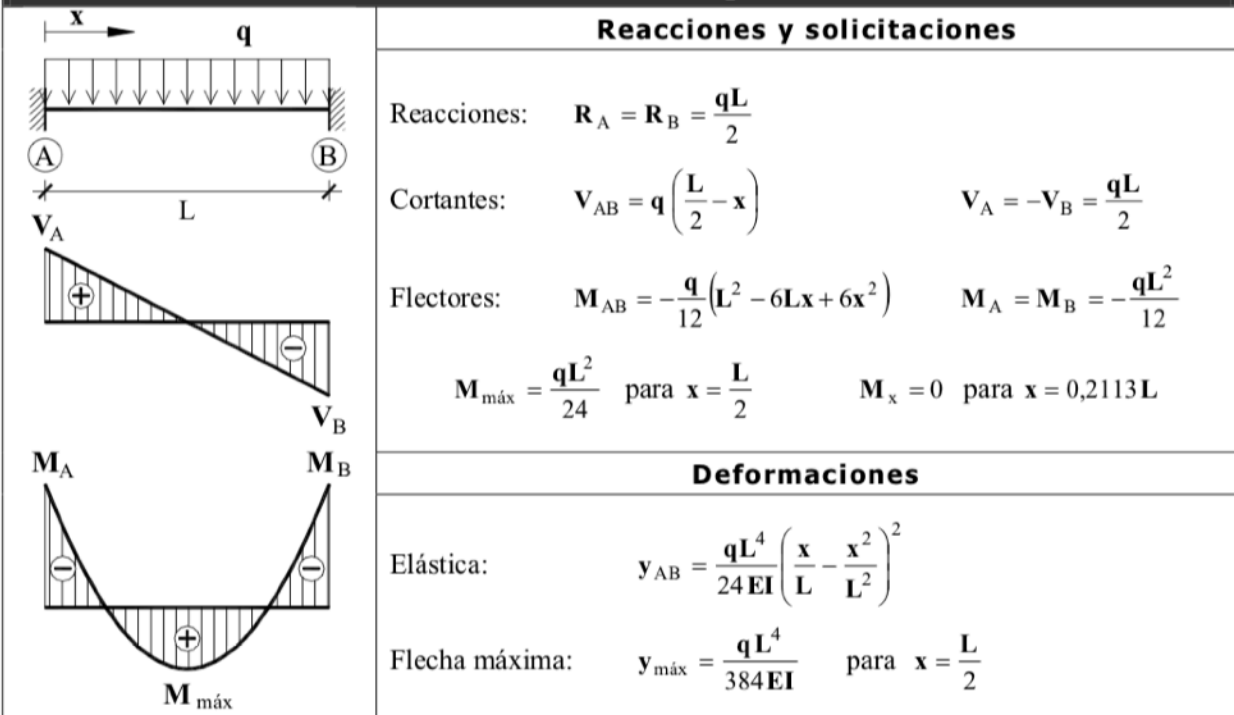

Image 2.9.2 - Mf max calculation

<https://rua.ua.es/dspace/bitstream/10045/25612/1/Estructuras%20Metálicas%20-%20Material%20apoyo.pdf>



Mechanical Properties	Comments
Hardness, Rockwell R	Average value: 107 Grade Count:274
Ball Indentation Hardness	Average value: 100 MPa Grade Count:49
Tensile Strength, Ultimate	Average value: 38.8 MPa Grade Count:169
	Average value: 35.8 MPa Grade Count:3
Tensile Strength, Yield	Average value: 44.1 MPa Grade Count:436
	Average value: 64.0 MPa Grade Count:1

Image 2.9.3-Tensile Strength

[http://www.matweb.com/search/DataSheet.aspx?](http://www.matweb.com/search/DataSheet.aspx?MatGUID=eb7a78f5948d481c9493a67f0d089646&ckck=1)

MatGUID=eb7a78f5948d481c9493a67f0d089646&ckck=1

The next calculation is it to fit the pressure joints in two different pieces. First one, the pressure joints that will join the two pieces of SCC back case.

In order to determine minimum and maximum pressure, research on hydrostatic pressure in seawater has been made, for it has a greater density and it represents a more unfavorable situation; data about pressures at 1 m and 25 m of depth was obtained. 25 meters has been chosen so the product can resist the pressure at this depth, but also so the user can open it without any special tool needed and the minimum pressure it is considered to make the case watertightness . These pressures have been converted to the equivalent forces that each cylinder that keeps both case's parts together need to exert. It will be considered:

$e=1,5 \text{ mm}$, $L= 8 \text{ mm}$, $D= 8 \text{ mm}$, $E = 2,03 \cdot 10^9 \text{ Pa}$, $\text{Coef.roz} = 0,15$

$$P = d \cdot g \cdot h$$

$$P_{min} = 1027 \cdot 9,8 \cdot 1 = 1,006 \cdot 10^4 \text{ Pa}$$

$$P_{max} = 1027 \cdot 9,8 \cdot 25 = 2,51 \cdot 10^5 \text{ Pa}$$

$$P_{min} = \frac{F_{min}/n}{2\pi \cdot b \cdot \mu \cdot L} = 1,421 \cdot 10^4 \text{ Pa}$$

$$P_{max} = \frac{F_{max}/n}{2\pi \cdot b \cdot \mu \cdot L} = 3,79 \cdot 10^5 \text{ Pa}$$

$$a = \frac{D}{2} - e = 3 \text{ mm}$$

$$b = \frac{D}{2} = 4 \text{ mm}$$

$$c = \frac{D}{2} + e = 5 \text{ mm}$$

The pressure was chosen to make the case watertightness. With that pressure and with this formulae it can be able to get the force that it will need necessary to a good pressure joint and waterproof one.

This force will be divided between the numbers of cylinder that will make the joint (7) and then will obtain the force that every cylinder needs to make.

It is considered that the hole must have an "H" position, and that the hole's manufacturing tolerance matches the axis' one.

$$y_{min} = \frac{P_{min} \cdot b}{E} \cdot \left(\frac{c^2 + b^2}{c^2 - b^2} + \frac{b^2 + a^2}{b^2 - a^2} \right) = 0,27 \mu m$$

$$y_{max} = \frac{P_{max} \cdot b}{E} \cdot \left(\frac{c^2 + b^2}{c^2 - b^2} + \frac{b^2 + a^2}{b^2 - a^2} \right) = 6,07 \mu m$$

This is the minimum and maximum deformation that will be considered for this join.

The hole has a H tolerance and T=t

$$D_i = 0 \mu m$$

$$T + t \leq 2 (y_{max} - y_{min})$$

$$T \leq y_{max} - y_{min} \leq 5,8 \mu m$$

$$IT_4 \rightarrow T=t=4 \mu m$$

$$D_s = D_i + T = 4 \mu m$$

$$d_i - D_s \geq 2y_{min}$$

$$d_i \geq 2y_{min} + D_s \geq 4,54 \mu m \rightarrow \text{RULE 1}$$

Chart $\rightarrow m$: $d_i = 6 \mu m \rightarrow$ and follow the RULE 1

In some points it will be necessary to check a board with all the tolerances, IT and deformation to choose which is the best option for this calculation.

The position "m" was obtained checking a board with hole and axis's deformation.

$$d_{\min} = 2\gamma_{\min} + D_s$$

$$d_s = d_i + t = 10 \mu\text{m} \rightarrow \text{Follow the RULE 2}$$

$$d_s - D_i \leq 2\gamma_{\max}$$

$$d_s \leq 2\gamma_{\max} + D_i \leq 12,14 \mu\text{m} \rightarrow \text{RULE 2}$$

Finally, the adjustment is H4m4

Image 2.9.4 - Pressure joints SCC

Finally, the necessary adjustment to create these parts is H5n5.

The last problem that will be considered: the same situation, but this time for the earbud's dimensions.

It will be considered: $D=5,5 \text{ m}$, $e=1,5\text{mm}$ and $L=12\text{mm}$

$$P = d \cdot g \cdot h$$

$$P_{\min} = 1027 \cdot 9,8 \cdot 1 = 1,006 \cdot 10^4 \text{Pa}$$

$$P_{\max} = 1027 \cdot 9,8 \cdot 25 = 2,51 \cdot 10^5 \text{Pa}$$

$$P_{\min} = \frac{F_{\min}}{2\pi \cdot b \cdot \mu \cdot L}$$

$$P_{\max} = \frac{F_{\max}}{2\pi \cdot b \cdot \mu \cdot L}$$

$$a = \frac{D}{2} - e = 1,25\text{mm}$$

$$b = \frac{D}{2} = 2,75 \text{ mm}$$

$$c = \frac{D}{2} + e = 4,25 \text{ mm}$$

$$\gamma_{min} = \frac{P_{min} \cdot b}{E} \cdot \left(\frac{c^2 + b^2}{c^2 - b^2} + \frac{b^2 + a^2}{b^2 - a^2} \right) = 0,54 \mu\text{m}$$

$$\gamma_{max} = \frac{P_{max} \cdot b}{E} \cdot \left(\frac{c^2 + b^2}{c^2 - b^2} + \frac{b^2 + a^2}{b^2 - a^2} \right) = 13,47 \mu\text{m}$$

The hole has a H tolerance and T=t

$$D_i = 0 \mu\text{m}$$

$$T + t \leq 2 (\gamma_{max} - \gamma_{min})$$

$$T \leq \gamma_{max} - \gamma_{min} \leq 12,93 \mu\text{m}$$

$$\text{IT 7} \rightarrow T=t=12 \mu\text{m}$$

$$D_s = D_i + T = 12 \mu\text{m}$$

$$d_i - D_s \geq 2\gamma_{min}$$

$$d_i \geq 2\gamma_{min} + D_s \geq 13,08 \mu\text{m} \rightarrow \text{RULE 1}$$

Chart \rightarrow r : $d_i = 15 \mu\text{m} \rightarrow$ and follow the RULE 1

$$d_{imin} = 2\gamma_{min} + D_s$$

$$d_s = d_i + t = 27 \mu\text{m} \rightarrow \text{RULE 2}$$

$$d_s - D_i \leq 2\gamma_{max}$$

$$d_s \leq 2\gamma_{max} + D_i \leq 26,94 \mu\text{m} \rightarrow \text{DO NOT follow the RULE 2}$$

In this case, what happened is that the rules were not followed, which means a step back needs to be taken and a lower IP needs to be chosen, until the result meets inequalities.

$$d_{imin} = 2\gamma_{min} + D_s$$

$$d_s = d_i + t = 27\mu m \rightarrow \text{RULE 2}$$

$$d_s - D_i \leq 2\gamma_{max}$$

$$d_s \leq 2\gamma_{max} + D_i \leq 26,94\mu m \rightarrow \text{DO NOT follow the RULE 2}$$

$$IT 6 \rightarrow T = 8\mu m$$

$$D_s = D_i + T = 8\mu m$$

$$d_i - D_s \geq 2\gamma_{min}$$

$$d_i \geq 2\gamma_{min} + D_s \geq 9,08\mu m \rightarrow \text{RULE 1.B}$$

Chart \rightarrow $d_i = 12\mu m$ \rightarrow and follow the RULE 1.B

$$d_{imin} = 2\gamma_{min} + D_s$$

$$d_s = d_i + t = 20\mu m \rightarrow \text{RULE 2.B}$$

$$d_s \leq 2\gamma_{max} + D_i \leq 26,94\mu m \rightarrow \text{Follow the RULE 2.B}$$

Finally, the adjustment is H6p6

Image 2.9.5 - Pressure joints earbud

When creating the prototypes or doing a real test, the possibility of joining the case's parts with screws would be considered, for it would provide a better tightness and safety to the container.

Appendix 2.10 - Charged battery

There are many different solutions on how to power the required electronic components: alkaline battery, wire-charged battery (micro-usb, type c, etc.), or wireless charging. In order to choose the most adequate option for this design, the following table exposes positive and negative aspects of all three methods:

Options	Advantages	Disadvantages
Alkaline battery	The electronic-device case does not need a hole to pass any cord though.	Once the battery dies, the electronic case will need to be opened in order to replace it.
Wire-charged battery	Fast charging. The case does not have to be opened every time the battery needs to be recharged.	The case needs to be punched out in order to place a usb port for battery charging. Moreover, this port must be somehow sealed, for water could leak inside the electronic components otherwise.
Wireless-charged battery	The electronic-device case does not need a hole to pass any cord though. The case does not need to be constantly opened.	Slow charging compared to wire-charged batteries. There are not that many available options in the market regarding this charging method.

Chart 2.10.1- Different batteries

After this comparison, wireless charging has been selected as the most appropriate option, for it does not require any port holes in the electronic case; this condition avoids the previously mentioned water-leaking problem, increasing the case's impermeability. Moreover, by choosing wireless charging, the case would not need to be opened every time an alkaline battery ran low, situation that would probably be uncomfortable for the user or it could compromise the case's impermeability if it were not correctly closed. After researching on wireless-charging general functioning, two different variants of this charging method were found:

- Inductive charging: both the device to be charged and the charger must be in permanent contact, and their respective coils must be aligned with each other.

- Resonance charging: the device to be charged and the charger need to be close to each other, but not necessarily in permanent contact.

Deeper research on these two methods showed that inductive charging is significantly safer than the other one, because the fact that both the source and the receiver are in permanent contact eliminates the possibility of micro electric discharges. Moreover, resonance charging delivers up to 7 volts while inductive charging can go up to 15 V.

Some disadvantages on wireless charging are that, even though there is a “fast charging” mode, it is naturally slower than conventional through-wire charging. On the other hand, energy loss through heat dissipation is significantly greater in wireless charging, and that is why it is never runs at its maximum power.

Another peculiarity of this charging method is that both the charger and the charged device must be made out of a non-metal, for they would conduct electricity otherwise. Energy emitted would be induced by a metallic body of the charger, and this would significantly increase heat dissipation losses, blocking the charging process.

How does wireless charging work?

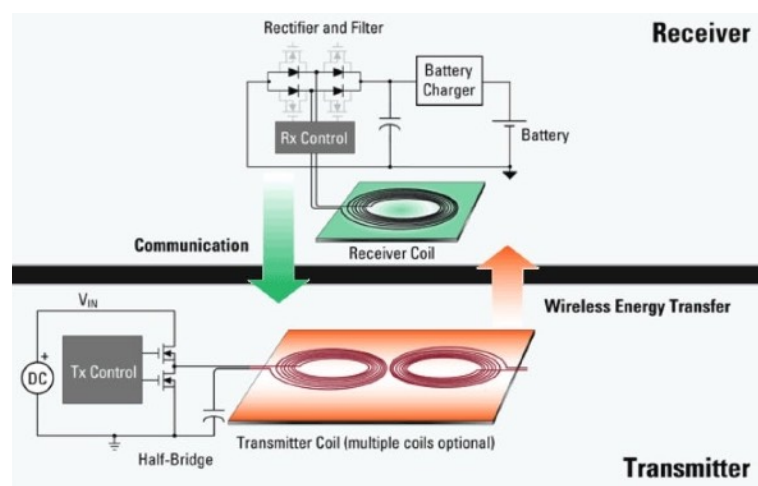

Image 2.10.2 - Wireless charging

Inductive charging steps:

1. An electric signal is emitted by an external coil located at the charging base. This charging base would be either sold as a separate item or as part of the wetsuit.

2. This electric signal is caught by a receiver coil, and this coil will be part of the internal battery of the wetsuit.
3. Electromagnetic induction begins when the internal coil starts receiving the emitted signal;
 - An electric current starts flowing through the transmitter coil.
 - This electrons flow generates a magnetic field that is immediately identified by the electrons contained in the receiver coil.
 - At the same time, this magnetic field generates an electron flow through the receiver coil.
 - Finally, this induced current flow in the receiver coil will charge the wetsuit's battery.

As it has been mentioned before, both the transmitter and the receiver coils must be aligned with each other in order for the charging process to be successful; that is the reason why smartphones and/or wireless chargers show drawings or simple explanations on how to orient the receiver device. However, wireless charging devices' manufacturers have already come up with a solution for this potential limitation; it consists on placing many transmission coils at diverse locations and orientations of the charging base, allowing the receiver device to find an aligned coil regardless of its orientation, and therefore, letting the charging process happen. This system is commonly known as free positioning electromagnetic induction.

There are different alternatives when it comes to wireless charging, but the most advanced protocol and the one with better performance characteristics is the Qi standard. This standard was originally developed in 2008 by the Wireless Power Consortium (WPC), and it consists of an open source cooperation between Asian, American and European companies whose objective is to come up with a global standard for inductive charging technology.

When both coils are in contact, a generated magnetic field induces an alternate electric current that eventually charges the receiver device (Faraday's law).

Implied restrictions on using the Qi technology are that both the base and the receiver coils (located at the battery to be charged) must be compatible with this standard; moreover, the distance in between these two coils should never exceed **4 cm**. Since Qi works with electromagnetic induction, whenever there is no device to be charged near the transmission coil, it remains inactive, but it is constantly emitting electric pulses in order to identify any other Qi device that might be close and ready to be charged. On the other hand, when a Qi device is fully charged (100%), the charging base receives a pulse with this information, and it turns itself off.

The distance between the transmission and receiver coils is typically 5 mm. However, as it has been mentioned before, this distance can be increased up to 40 mm. The outgoing electric current is regulated by a digital control circuit in which the receiver communicates with the transmitter in order to require less or more energy.

Important information to be considered when designing the electronic device:

- The receptor coil is connected to the battery through some pins.
- The separation distance between the charging base and the receptor coil cannot exceed 4 cm.
- Neither the charging base nor the electronic device's case can be metallic, for this kind of materials would behave as conductors, enhancing the energy loss process.
- Qi wireless chargers generally deliver a greater amount of volts than conventional wire chargers; they are less efficient, so they have to compensate their energy losses with higher voltage.
- At conventional charging parameters, 9 V and 13 A, the charging process would be inefficient if, due to energy losses, 15 W of power could not be delivered to the battery. Therefore, the power source selected for this project must be able to deliver this power while the battery charging process is on going.

Appendix 2.11 - Different possible gases

Which kind of gas should be used for compressed - gas capsules. Three different gases have been proposed to be used in this project. These gases are the following:

-Helium

-Nitrogen.

-Carbon Dioxide.

These three gases were initially chosen, for they are commonly used in similar purposes projects: hot air aerostatics ballons, weather-monitoring ballots, lifejackets, etc...

After researching about various different characteristic of all three gases, it is been found out that hydrogen's elevation power is 8,5% greater than that oh helium's. This is due to the fact that the earth's atmosphere is composed by the following mixture. 78% Hidrogen, 20.9% origen, 0.9% argon and 0.2% of other various different molecules; this mixture's density equals 1.2 g/L at sea level, and under these conditions hydrogen's density equals to 0,008988 g/L.

Even though helium has a greater density than hydrogen (0,1786 g/L), its resulting elevation force equals 0.0100N in absolute magnitude, which is smaller than hydrogen's. Both hydrogen and helium's elevation forces are actually greater than that of carbon dioxide's (CO₂). Therefore their corresponding elevation capacities go as follows:

Nitrogen > Helium > CO₂.

But another factor that must be taken in consideration in the appropriate gas selection process, is that hydrogen is highly flammable while helium and CO₂ are not.

Moreover, and more importantly, there are CO₂ capsules already available in the market that could easily be integrated in the proposed design. If this were not the case, manufacturing customized compressed- gas capsules would significantly increase the final product's market price.

CO₂ capsules are already being used in various PFD's (Professional Floating Devices) and lifejackets; Therefore, using CO₂ capsules will be the most appropriate option in order to develop this brand new design.

Appendix 2.12 - Valves:

This section turned out to be one of the most important and crucial parts of the project. It consists on automatically detonating the CO₂ capsule after the **central control system** (Arduino) has given that order; this order will only be given if the previously explained safety values (pulse, blood oxygen, GPS) are somehow reached by the user.

Research on this topic started by investigating how similar available products had overcome this problem, and it all comes down to a plastic piece called Super Bobbin. This piece has a cellulose on the inside that rapidly degrades when water comes into contact, releasing a spring that pushes a needle in order to penetrate the CO₂ capsule. As an alternative solution, this spring can also be released by consuming a salt tablet instead of the previously mentioned cellulose when water comes into contact.

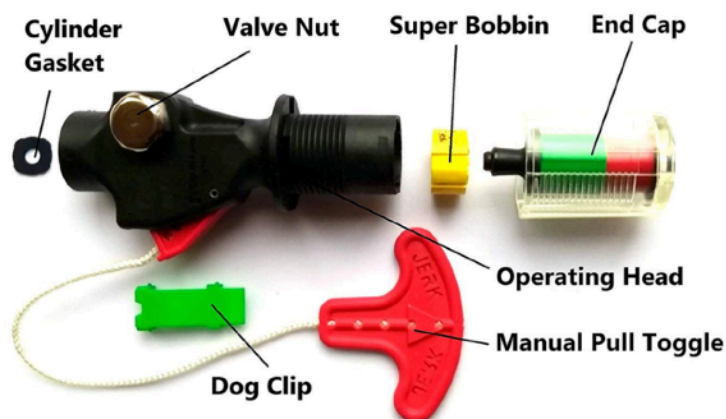

Image 2.11.1 - Conventional valve

However, these automatically released floating devices are designed for airplane passengers, a ship's crewmen, or other similar applications in which people are not supposed to come in contact with water; in case this happened, the Super Bobbin or the

salt tablet would rapidly release the spring mechanism, inflating the floating device almost instantly.

Given these conditions, this activation system is not a viable option for the proposed design, for this wetsuit is meant to be in contact with water (or even under water) almost 100% of the time it is being used.

The following sections cover different mechanisms, materials and activation systems that could potentially solve this problem:

Piezoelectric materials:

Piezoelectric materials was one of the possible options:

Piezoelectricity is a characteristic phenomenon of some materials that are able to polarize their mass as a response to mechanical stress, generating a resulting voltage.

However, the importance of this phenomenon for this project is that it also occurs the other way around. If a certain voltage is applied to a piezoelectric material by letting an electric current flow through it, this material will strain as a result of the internal forces generated in its inner mass by the electric field.

Knowing the properties of this type of materials, the idea was to have a piezoelectric material hold a compressed spring, and once the inflation mechanism needed to be released, an electric current would flow through this piezoelectric material, causing a sufficient length decrement in order to release the spring. This spring would then push a needle in order to perforate the CO₂ capsule, letting its gas expand all inside the floating compartments.

However, a different research line on this type of materials showed that their length deformation as a response of an applied voltage is in the range of micrometers; bigger

deformations could be reached at considerably higher temperatures, but this condition makes it impossible to use this materials for this project.

Electro-valves:

Similar to any other type of valves, electro-valves are capable of permitting or stopping a liquid flow through a system or a circuit. This valve opens and closes when a magnetic field is generated by a coil in order to attract a piston; after an electric signal is emitted, this piston moves upwards or downwards in order to let the fluid flow or stop flowing, depending on the piston's original position. There are different types of electro-valves, being the following the most relevant ones:

This part slides inside a pump or a valve. In this particular case, it s driven by a magnetic field, letting the liquid flow through the valve.

Given this project's purposes, an electro-valve could let water inside a designated zone of the device in order to consume the cellulose or a salt tablet; this would rapidly activate the inflation mechanism the same way that common automatic lifejackets are currently being activated.

A different option would be to have a super small container with water or some other liquid, and the electro-valve would let the liquid flow only after receiving a signal from the **central control system** (Arduino) when the user is experiencing a dangerous (or even life-threatening) situation. However, this option requires the liquid container to be re-filled every time the user activates the floating device.

The main disadvantage of this option is that, in order to activate the inflation mechanism, a fair amount of water must be let inside the system. Therefore, both the location of the liquid container and the way to let water flow into the system without

compromising the integrity of the electronic components, must be extremely carefully studied and determined.

Moreover, it needs to be determined whether the weight and dimensions of these type of valves are appropriate for this specific project. In case they are not, a potential solution is to create a smaller and lighter valve that is capable of fulfilling the same objectives.

Electromagnets:

Another possible option is to incorporate electromagnets in the design.

An electromagnet is an artificial magnet whose core is made of iron. It does not have the same properties as an actual magnet, but it can temporarily acquire those properties. The soft iron core becomes a magnet when an electric current flows through a copper coil that is rolled around that core.

Electromagnets have significant advantages over natural magnets, for they can be activated and deactivated when necessary, and their attraction force can be regulated by increasing or decreasing their magnetic field intensity.

This type of magnets have numerous applications like: electromagnetic breaks

As it has been mentioned before, electromagnets consist of a soft iron core that is surrounded by a copper wire; when an electric current flows through this wire, the core's molecules rearrange and align themselves, generating both positive and negative poles in this material.

This system could potentially be used as follows:

1. A ferrous material could be blocking the spring (the one that pushes the needle to detonate the CO₂ capsule), and this material would eventually move and release the spring as the electromagnet were activated.

2. This ferrous material could have an integrated needle, and when the electromagnet were activated, this needle would move towards the CO₂ capsule in order to detonate it and free its inner gas.

Hydrostatic system

This system works in a way that, when the castaway submerges under water, pressure naturally increases due to the weight water exerts on the user. A membrane (that prevents water from entering the system) breaks due to the pressure increase, and it lets water inside. This water consumes a salt table/cellulose that causes a firing pin to penetrate and open the CO₂ capsule, releasing all its gas and automatically inflating the vest.

Chart 2.13.3 - Oxygen percentage

In order to implement this alternative, the pressure value required to break the membrane would need to be carefully studied and determined. However, this solution would not really be reliable, for some user could find themselves under water due to the activity they are practicing, and not necessarily because they are experiencing a dangerous situation.

Appendix 2.13 - Oxiometry:

It is a non-invasive method that can be used to estimate the arterial oxygen saturation level while monitoring both the heart rate and the pulse wave amplitude of the person. Considering this project's purpose, integrating an oximeter would mean more control over the user and over accurately deciding whether he/she is experiencing a dangerous situation. If its pulse reaches too high values, it could mean that person finds itself in danger (the heart rate upper limit before being considered "too high" must be carefully determined, for the pulse can reach very high frequencies if the user is under adrenaline effects). On the other hand, if the level of blood oxygen saturation drops under normal values, it would mean the user is rapidly running out of air or even already drowning. Considering this option, the Central Control System (CCS) would now have two more values / conditions to decide whether the floating system should be activated or not. But first of all, the way this procedure works will be detailedly explained:

Blood is oxygenated as it flows through a person's lungs; hemoglobin (**Hb**) transforms into oxyhemoglobin (**HbO₂**), which basically implies it can now transport oxygen. However, the interesting part about this phenomenon is that, these two composites have different levels of absorption of the different light wave lengths. It is mostly between 650 **nm** (red) and 950 **nm** (infrared) that the difference between these two composites can be easily appreciated.

Up to approximately 800 **nm**, hemoglobin absorbs light (red), and it is at this point where things get inverted, being the oxyhemoglobin the one that now absorbs more light (infrared).

Therefore, if we consider that these two composites have different behaviors when exposed to different wave lengths, oxygen presence or absence in blood can be detected, and this information can be used to determine the heart rate.

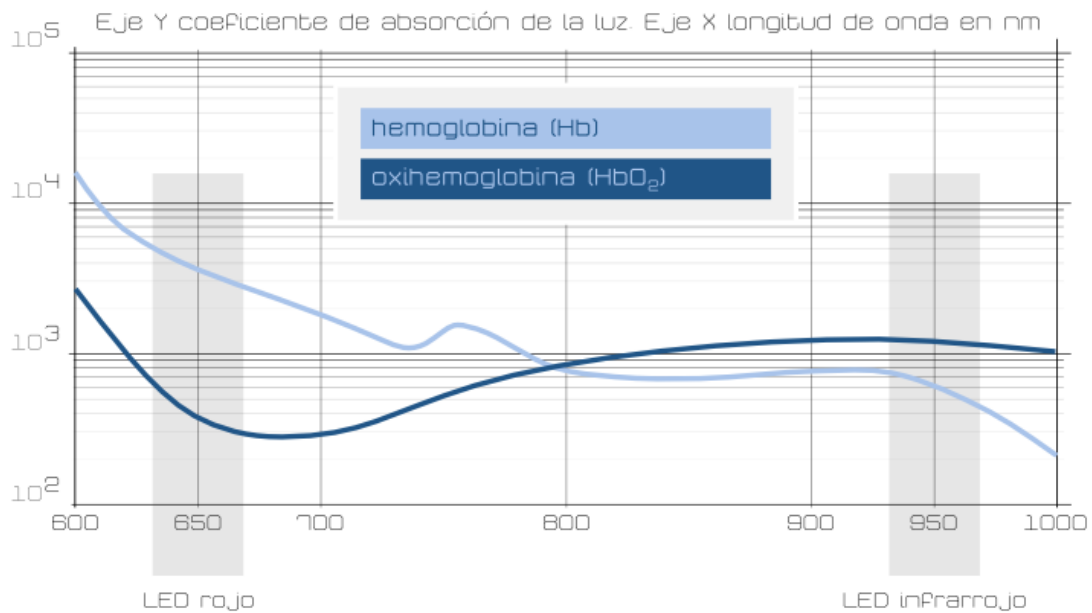

Image 2.13.1 - Hemoglobine and oxihemoglobine

The best way to observe this phenomenon is by checking the light behavior when it travels through a translucent part of the human body (in an adult, this part could be a finger, an earlobe or its nose). However, this project considered placing this monitoring device in the user's wrist. It could be located at the extreme part of the suit's arm, for this part would be in contact with the user's wrist; on the other hand, this device could also be an independent bracelet.

However, this area of the human body is not one of the previously mentioned translucent parts, so in order to ensure the effectiveness of the device in this area, the Biomedical Engineer Nadia Paulina González was contacted and consulted on this topic. She warned that this device could be placed in the user's wrist, but instead of monitoring the light that travels through this area, it would be necessary to focus on the reflected light, for this is a considerably thicker part and light cannot travel through it.

Moreover, it is important to consider that this area has a considerably large number of veins and arteries, which means the diagnosis would need to be centered in just one of

these arteries in order to avoid mistakes when taking measurements. There could be significant variations in time or amount of CO₂ in the user's bloodstream depending on the chosen artery.

Finally, once the light was reflected, the receptor's adequate location would be fairly complicated to determine, for light would bounce at an unknown angle, which means this angle would need to be carefully studied in order to determine the receptor's correct position.

Continuing with the explanation of the oximetry operation process...

The device emits a red light, and it also detects its intensity after that light traveled through the bloodstream. The same procedure is repeated with infrared light, and depending on the different light intensities detected, the level of blood oxygen can be determined.

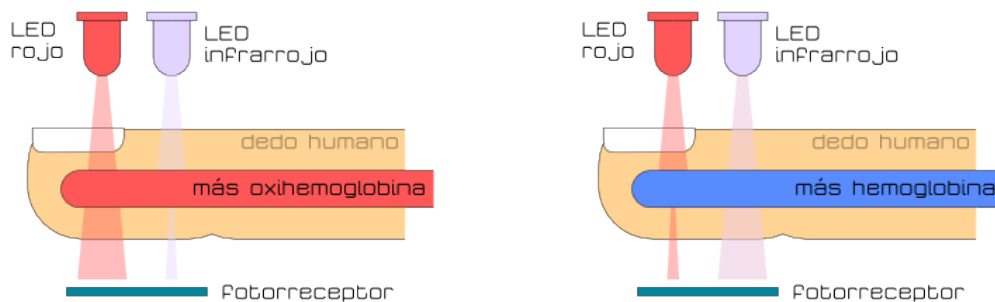

Image 2.13.2 - Leds and oximetry

This procedure turns out to be the most precise way to measure this value. There is an easier way to calculate it by measuring the amount of light that travels all the way through this area, but this method requires a high level of darkness within the measuring device, and this is considerably complicated to achieve, especially in this project considering the environment in which this device is intended to be used.

Response according to % of saturation	
% of Saturation	Response
> 95 %	Not immediate response needed.
95-90 %	Immediate treatment and patient's response monitoring. Depending on this response, consider transporting to hospital. Patients with chronic respiratory conditions can properly tolerate these levels of saturation.
< 90 %	Seriously ill. Severe hypoxia. Oxygen therapy + treatment and transport to hospital.
< 80 %	Consider intubation and mechanical ventilations.

Children with < 92%: Transport to hospital even if their condition improves with initial maneuvers; their treatment response can be uncertain.

Modern devices are very reliable when the patient's blood oxygen saturation is above 80%.

There are some situations that could potentially cause mistaken readings, some of which need to be carefully considered for this project:

- Interference with other electronic devices.
- Intense ambient light: xenon, infrared, fluorescent...
- Obstacles for light absorption: nail dye (remove with acetone), skin pigments (use the fifth finger or an earlobe).

Appendix 2.14 - Bone conduction

Sound waves are vibrations that travel through air and eventually reach our eardrum; this ear part vibrates in order to decode the received waves, turning them into new vibrations that are transmitted to our inner ear. It is also connected to the auditory nerve, and transmits these vibrations to our brain, being this last muscle the one who turns these vibrations into the sound we hear.

Bone conduction works by avoiding contact with the eardrums, and traveling directly to the inner ear as vibrations; this, at the same time, keeps the eardrum damage free.

Products that incorporate this technology decode sound waves and then turn them into vibrations that can be received directly by the inner ear. Sound itself reaches the ears as vibrations that travel through bones and through the skin.

Appendix 2.15 - Material:

Wetsuit materials;

This section of the study deepens on the most commonly used material for this type of suits, neoprene; its thermal and elastic properties make this material the most appropriate for these specific purposes.

Neoprene suits have been used in aquatic recreational activities since the 1960's, and it is a synthetic material that contains gas bubbles in its core composition. This gas is usually nitrogen, and these bubbles are the ones that actually provide both thermal insulation and flexibility to the wetsuit; the rubber itself is not doing any insulation, its the inner gas that is preventing heat from leaving.

- The more bubbles there are, the greater the insulation capacity (ability to keep body temperature stable), and the more flexible the suit will be. Since there are more bubbles inside the rubber, this material is less dense, and therefore, more flexible.
- The less bubbles there are, the poorer the insulation capacity. The suit will not be able to keep body temperature stable, and it will also be a little more rigid. Less gas bubbles result in more rubber, which implies these type of neoprene will be denser.

However, it is not only about the amount of bubbles in the neoprene, but also the size of those bubbles. If two neoprene suits have the same density (same volume occupied by gas in the same volume of rubber), but one of them has smaller bubbles than the other one, this suit with more smaller bubbles will have a better insulation capacity.

A good neoprene suit is supposed to provide enough thermal insulation to keep body temperature at a certain level, and it should also be fairly flexible; these two characteristics translate in as many gas bubbles as possible. However, there is another consideration that should also be made, and that is the neoprene's durability. It turns out

that the more smaller bubbles a neoprene suit has (warmer and more flexible), the less long-lasting it will be.

Therefore, an equilibrium point between these two characteristics will result in the maximum user satisfaction, aiming to achieve the best possible combination between neoprene's quality, in-water performance characteristics, and price.

Nowadays, neoprene is combined with some other materials like lycra or spandex in order to improve its flexibility and resistance. The most commonly used materials in modern suits are standard neoprene, extra-elastic neoprene, and waterproof extra-elastic neoprene, this last one being the best and also the most expensive one. That is the reason why manufacturers use certain type of materials only in some specific parts of the suit.

Surfers, for example, need at least 30% of extra-elastic neoprene in their back, shoulders and arms, in order to ease their upper body mobility. On the other hand, there are some other suits that are made 60% of this extra-elastic material (covering thighs and knees), and some others that are 100% extra-elastic, enabling extreme flexibility, lightness and perfect fit. However, these super elastic materials are less resistant, and their useful life might be shortened if they are not treated correctly.

There is also a different classification for neoprene suits depending on their cover materials; these covers are generally nylon, or lycra.

- External cover suits: Cover materials are placed on the outside face of the suit, while flat neoprene covers the inside. This is a typical suit for submarine fishing.
- Internal cover suits: An internal cover enhance the suit's resistance and it eases the putting on and taking off processes. These type of suits are very thin and are generally used for swimming or windsurf.
- Both internal and external covers: Typical surfing wetsuits.

- No cover suits: Flat neoprene both on the inside and the outside faces. These are the most elastic suits, but they are also the most vulnerable ones, for they get easily degraded with the sun compared to those with external covers.

It must be taken in consideration that the insulation capacity of a suit does not only depend on its material, but also on how well it fits the user. Appropriate fitting will avoid water leaks into the suit, for if it occurs, not even the best or most expensive material will provide enough insulation to the user.

Appendix 2.16 - Material comparison

Silicone elastomers (SI, Q)

Ver hoja de datos: All properties Mostrar/ocultar

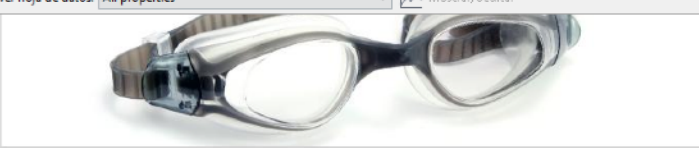

Caption
The silicone elastomer seal and strap of these swimming goggles resist chemical attack by bleaches and other chemicals. © Justus Blüner at Flickr - (CC BY 2.0)

The material
Silicones are high-performance, high cost materials. Silicone and fluoro-silicone elastomers have long chains of linked O-Si-O-Si- groups (replacing the -C-C-C-C- chains in carbon-based elastomers), with methyl (CH₃) or fluorine (F) side chains. They have poor strength, but can be used over an exceptional range of temperature (-100 C to + 300 C), have great chemical stability, and an unusual combination of properties (Silly Putty is a silicone elastomer - it bounces when dropped but flows if simple left on the desk).

Composition (summary)
Most common version: (O-Si(CH₃)₂)_n

General properties

Density	①	1,02e3 - 1,22e3	kg/m³
Price	①	* 3,82 - 5,68	EUR/kg

Mechanical properties

Young's modulus	①	0,005 - 0,05	GPa
Yield strength (elastic limit)	①	7,01 - 11,5	MPa
Tensile strength	①	7,01 - 11,5	MPa
Elongation	①	270 - 600	% strain
Hardness - Vickers	①	* 3,01 - 3,98	HV
Fatigue strength at 10 ⁷ cycles	①	* 2,8 - 4,59	MPa
Fracture toughness	①	0,133 - 0,927	MPa.m ^{0.5}

Thermal properties

Maximum service temperature	①	201 - 249	°C
Thermal conductor or insulator?	①	Good insulator	
Thermal conductivity	①	0,201 - 0,299	W/m.°C
Specific heat capacity	①	1,05e3 - 1,1e3	J/kg.°C
Thermal expansion coefficient	①	* 249 - 301	µstrain/°C

Acrylonitrile butadiene styrene (ABS)

Ver hoja de datos: All properties Mostrar/ocultar



Caption
1. ABS pellets. © Shutterstock 2. ABS allows detailed moldings, accepts color well, and is non-toxic and tough enough to survive the worst that children can do to it. © Gettyimages

The material
ABS (Acrylonitrile-butadiene-styrene) is tough, resilient, and easily molded. It is usually opaque, although some grades can now be transparent, and it can be given vivid colors. ABS-PVC alloys are tougher than standard ABS and, in self-extinguishing grades, are used for the casings of power tools.

Composition (summary)
Block terpolymer of acrylonitrile (15-35%), butadiene (5-30%), and styrene (40-60%).

General properties

Density	①	1,03e3 - 1,06e3	kg/m³
Price	①	* 2,31 - 2,78	EUR/kg

Mechanical properties

Young's modulus	①	2,08 - 2,75	GPa
Yield strength (elastic limit)	①	34,5 - 49,6	MPa
Tensile strength	①	37,8 - 51,8	MPa
Elongation	①	5 - 60	% strain
Hardness - Vickers	①	* 10 - 14,9	HV
Fatigue strength at 10 ⁷ cycles	①	* 15,1 - 20,7	MPa
Fracture toughness	①	* 1,47 - 4,29	MPa.m ^{0.5}

Thermal properties

Maximum service temperature	①	62,9 - 76,9	°C
Thermal conductor or insulator?	①	Good insulator	
Thermal conductivity	①	* 0,253 - 0,263	W/m.°C
Specific heat capacity	①	* 1,69e3 - 1,76e3	J/kg.°C
Thermal expansion coefficient	①	74 - 123	µstrain/°C

At the beginning, the idea of designing both the case's parts and the part that goes in between the ABS valve and the CO₂ capsule was being considered, specially because of their rigidity, price and mechanical properties.

However, a more elastic material was thought to be used for the earbud manufacturing. The problem here came up when calculating the adjustment needed to assemble all the different parts that compose the earbud; if these parts were made of silicone, they would be so flexible and flimsy, that it would be fairly complicated to find an adequate adjustment, for they could easily fall apart.

That is why it was finally decided to manufacture all the design parts with ABS, a cheaper, stronger and less polluting material than PVC, the other material that was being studied and considered to manufacture these parts.

Image 2.16.1 -Material

In order to obtain this data, the CES Edu Pack version program was used; this program is available in Jaume I University.

These images show the position of ABS, neoprene and silicone in terms of density and hardness, for the idea was to find a material that were not as heavy (for user's comfort), and that would have great mechanical properties at the same time (punches, fracture resistance...).

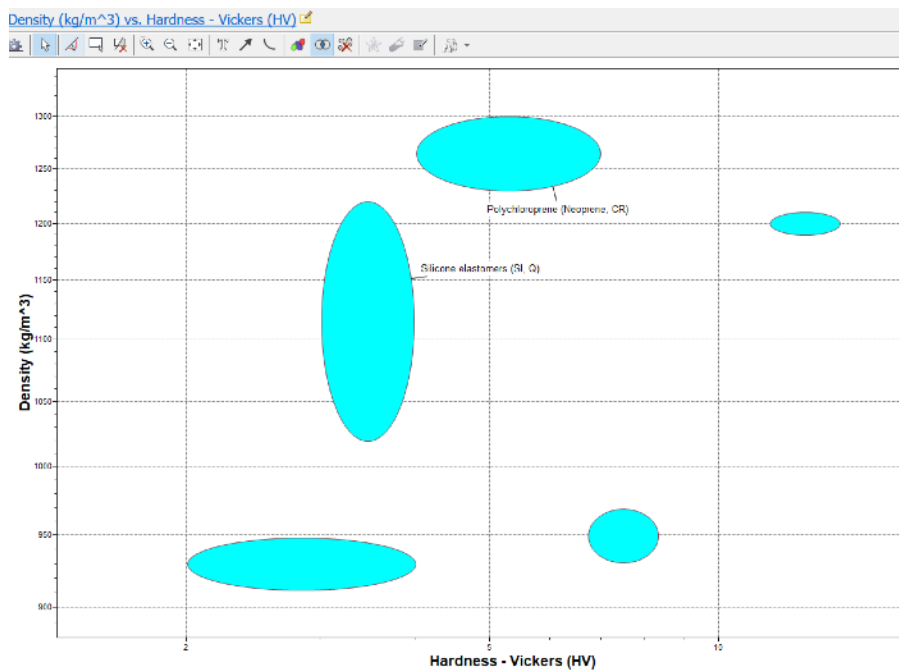
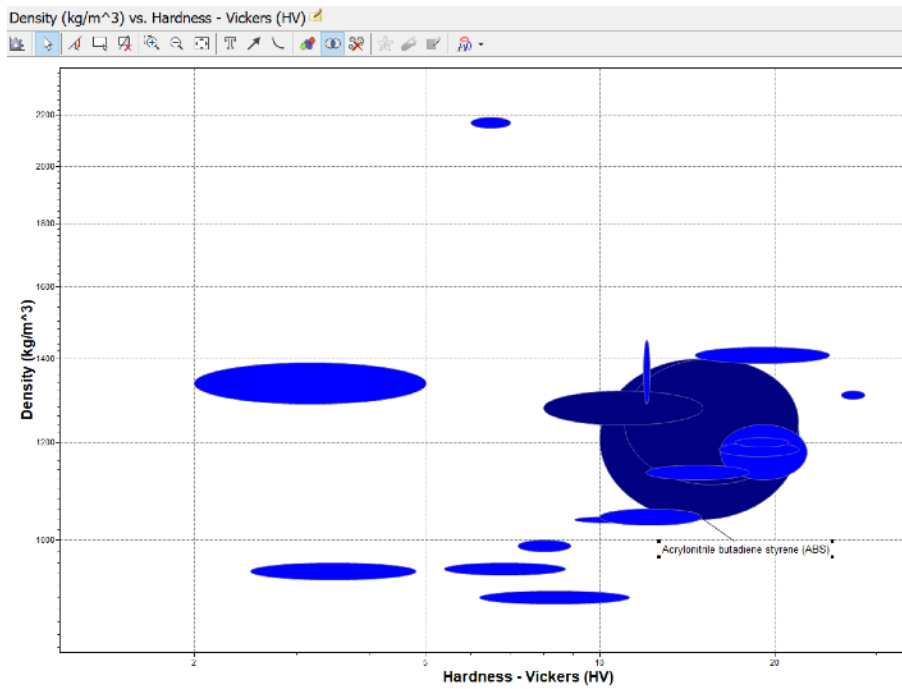

Image 2.16.2 -Material selection

Appendix 2.17 - Patent

Name: Solenoid valve

Year: 1991

Link: <https://patents.google.com/patent/US5029807A/en?q=solenoid+valve&oq=solenoid+valve>

Explanation on the web:

"A valve for sealing a conduit under pressure has an armature (12) cooperating with two springs, a permanent magnet, and a solenoid coil. The force of the permanent magnet is used to cock a spring and thereby stored primarily as a spring force when the valve is in any of its two end positions. The spring force is slightly smaller than the permanent magnetic force of the permanent magnet, and this slightly smaller spring force is effective on a valve stem through a sleeve in a direction opposite to that of the permanent magnetic force. The permanent magnetic force is, for example, stored in a Belleville spring and additionally in a helical or conical spring which provides an extra valve biasing force. In order to open the valve, the solenoid coil (9) of an electromagnet is energized to counteract the force of the permanent magnet to an extent slightly below the stored spring force. Thus, this valve is capable of having a monostable or a bistable characteristic, depending on the adjustment of the spring force with the aid of an adjustment ring engaging a threading on the valve stem."

U.S. Patent

July 9, 1991

Sheet 1 of 5

5,029,807

U.S. Patent

July 9, 1991

Sheet 3 of 5

5,029,807

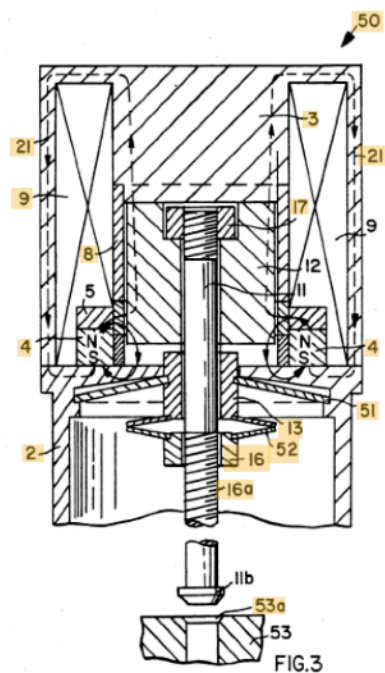
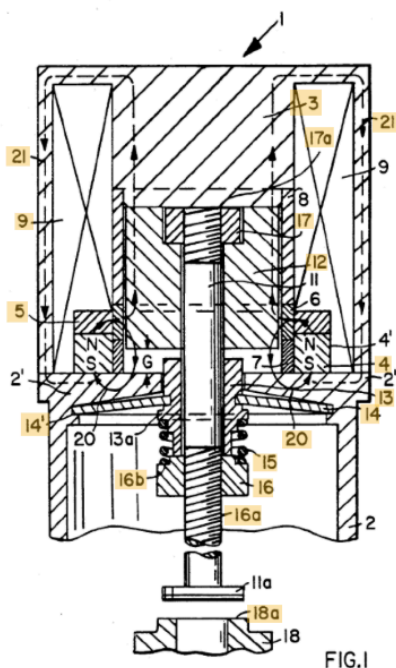

Name: Solenoid valve

Year: 1981

Link: <https://patents.google.com/patent/US4268009A/en?q=solenoid+valve&oq=solenoid+valve>

Explanation on the web:

"A solenoid-operated normally open two-way fluid control valve has a lever operably connecting a reciprocally movable solenoid plunger and a reciprocally movable seal pin. When the solenoid is in its deenergized condition the solenoid plunger acts upon the lever to maintain the seal pin in its normal open or unseated position. Energization of the solenoid removes the influence of the plunger upon the lever and permits the seal pin to be spring biased to its closed or seated position. When the solenoid is deenergized the solenoid plunger is spring biased toward the lever and acts through the lever to exert impact force on the seal pin to unseat it."

U.S. Patent May 19, 1981 Sheet 1 of 2 4,268,009

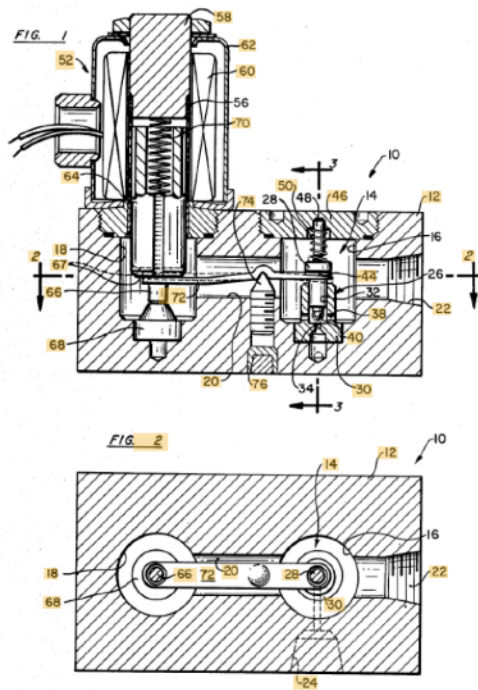

U.S. Patent May 19, 1981 Sheet 2 of 2 4,268,009

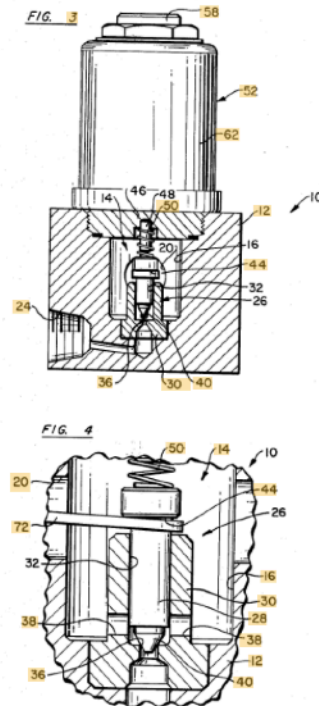

Name: Life jacket with cushioning air-bag

Year: 2001

Link: <https://patents.google.com/patent/US6230333B1/en?q=life&q=jacket&oq=life+jacket>

Explanation on the web:

“A life jacket with a cushioning air-bag comprises a jacket body (1), which includes a continuous torso air-bag portion (7) having a chest air-bag portion (2), a back air-bag portion (3), and a side air-bag portion (4), and further includes a neck air-bag portion (5) and a waist air-bag portion (6). The jacket body is provided with a gas generator (8) having a gas cartridge. Each of the air-bag portions (2, 3, 4, 5 and 6) has a dual structure composed of an outer bag (9) and an inner bag (10), which bags (9 and 10) are made of synthetic resin such as urethane or vinyl chloride. The gas generator (8) is connected to the outer bag (9) and inner bag (10) of each of the air bag portions (2, 3, 4, 5 and 6).”

U.S. Patent May 15, 2001 Sheet 1 of 6 US 6,230,333 B1

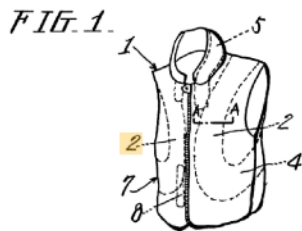

U.S. Patent May 15, 2001 Sheet 5 of 6 US 6,230,333 B1



FIG. 2.



FIG. 13.



U.S. Patent May 15, 2001 Sheet 6 of 6 US 6,230,333 B1

FIG. 14.

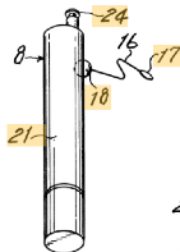
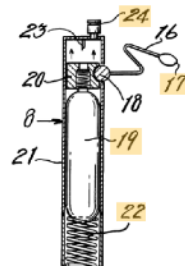

FIG. 15.



Name: Avalanche life-preserving jacket with airbag

Year: 2001

Link: <https://patents.google.com/patent/US6270386B1/en?q=life&q=jacket&oq=life+jacket>

Explanation on the web:

"An avalanche life jacket having an airbag inflatable by a gas release system upon actuation is disclosed. The life jacket provides a torso strap and buckles for attaching the life jacket to the user. Prior to inflation, the airbag is folded and enclosed within the harness. The harness encloses the airbag via an enclosure mechanism which opens during inflation of the airbag to allow the airbag to fully expand. The life jacket further comprises a gas release system which may be automatically actuated by an accelerometer and/or manually actuated by the user's pulling of a release handle. Upon actuation, the gas release system releases gas into and inflates the airbag. The airbag inflates to surround at least the back and sides of the user's head to thereby provide physical protection and a thermal buffer between a portion of the user and the external environment, for example, during and after an avalanche and to facilitate search and rescue of the user after the avalanche. The inflated airbag also provides a buoyant force against the downward force exerted by the current of the avalanche as well as a supply of breathable gas. A hood or mesh is also included to shield the user from the external elements such as snow and thereby facilitate in preventing injury and/or suffocation during a fall or an avalanche."

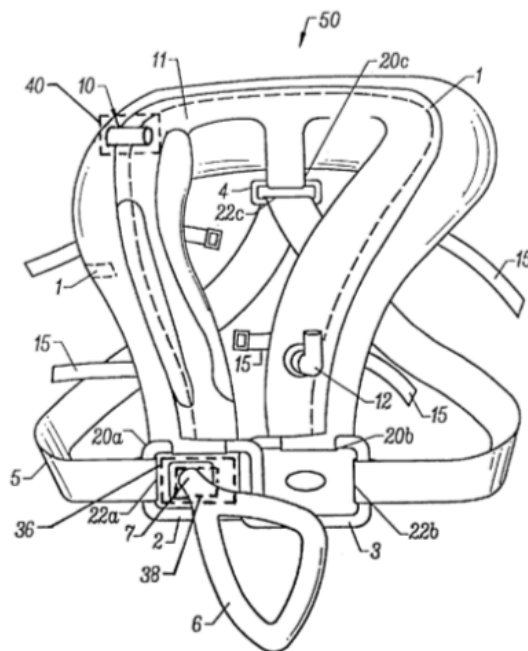

FIG. 1

Appendix 2.18 - Times calculation

Following the information founded in the next web: <http://iq.ua.es/TPO/Tema5.pdf>
It is going to calculate the time needed for the injection molding machine.

Tecnología de Polímeros. M. Beltrán y A. Marcilla



Figura 5.9. Duración relativa de las diferentes etapas del ciclo de inyección en una máquina convencional.

Image 2.17.1 -Time for the molding machine

This information it is really value for this project because it is a casualty that the thickness calculate in the Appendix 2.9 (1,54 mm) , this information gives the time necessary to produce pieces with this thickness.

This happen to two pieces used for the back, but the same thickness it all used for the earbuds.

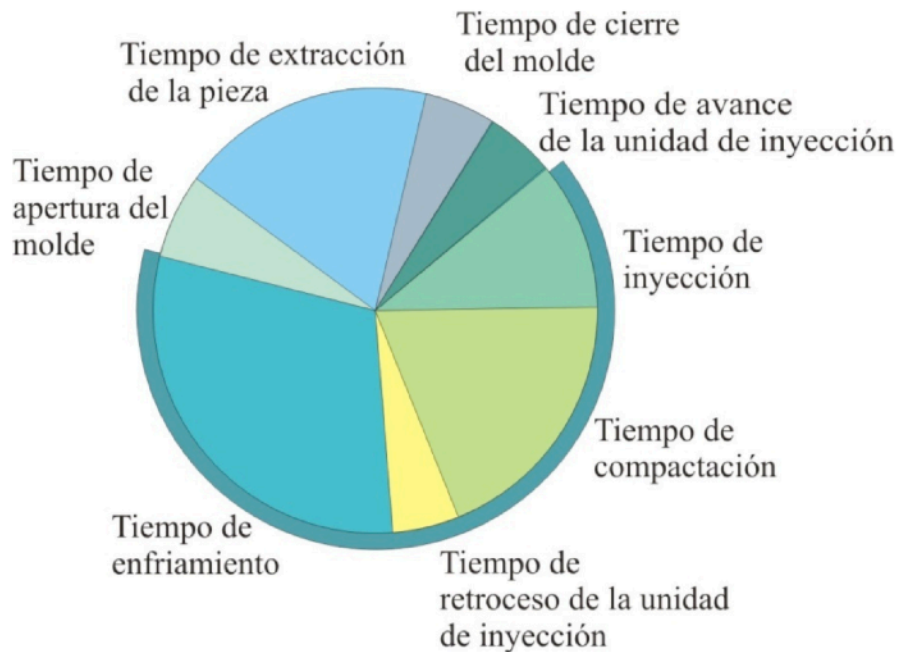
2.2.6. Tiempo de inyección inicial

El tiempo necesario para realizar la inyección depende de numerosos factores, como de cuanto material se está inyectado, su viscosidad, las características del molde y el porcentaje de la capacidad de inyección que se está empleando. En la mayoría de las máquinas el tiempo de inyección se divide en dos: el tiempo de inyección inicial y el tiempo de mantenimiento. El tiempo de inyección inicial es el tiempo necesario para que el tornillo realice el recorrido hacia adelante, obligando a que el material se introduzca dentro del molde. Normalmente este tiempo no es superior a 2 segundos, y rara vez excede los 3 segundos.

2.2.7. Tiempo de mantenimiento o compactación

El tiempo de mantenimiento o tiempo de compactación es el tiempo que, después de realizar la inyección inicial del material, el tornillo permanece en posición avanzada, para mantener la presión del material dentro del molde. Este tiempo se prolonga hasta que la entrada a la cavidad de moldeo solidifica. A partir de ese instante la cavidad de moldeo queda aislada del resto del sistema mientras continúa enfriándose por lo que prolongar el tiempo que el pistón permanece en posición avanzada carecería de sentido. Para una pieza de 1.5 mm de espesor el tiempo de mantenimiento no suele exceder de 6 segundos.

2.2.8. Tiempo de enfriamiento

Es una de las variables más importantes para conseguir una pieza de buena calidad. Es el tiempo que la pieza requiere para enfriarse hasta que ha solidificado y además ha adquirido la rigidez suficiente para poder ser extraída del molde sin que se deforme. Las partes más externas de las piezas se enfrían a velocidad más rápidas. El tiempo de enfriamiento debe ser suficiente para que un espesor considerable de la pieza (al menos el 95% de la pieza) se encuentre frío para evitar que la pieza se deforme. Lógicamente cuanto mayor sea el espesor de la pieza que se está moldeando mayor será el tiempo de enfriamiento requerido. Como media una pieza de 1.5 mm de espesor requiere de 9 a 12 segundos para solidificar y adquirir suficiente resistencia para poder ser extraída del molde sin deformaciones.

First of all, **parts to be manufactured:**

Case part 1 (ABS):

Injection molding time + cooling + retrieving = $3 + 6 + 9 = 18$ seconds per part
250 parts - 4500 seconds. This is 1,25 hours.

Case part 2 (ABS)

Injection molding time + cooling + retrieving = $3 + 6 + 9 = 18$ seconds per part
250 parts - 4500 seconds. This is 1,25 hours.

Part in between valves (ABS):

Injection molding time + cooling + retrieving = $3 + 6 + 9 = 18$ seconds per part
250 parts - 4500 seconds. This is 1,25 hours.

Four earbud parts (ABS):

Injection molding time + cooling + retrieving = $3 + 6 + 9 = 18$ seconds per part
250 parts - 4500 seconds. This is 1,25 hours.

But this one has 4 pieces so finally it is 5 hours.

Total → 8,75 hours

The next information has been known by Ana Martinez Iserte. After it was explained all the process. She approached a time to realize all the wetsuit.

Neoprene suit elaboration:

Creating both neoprene layers + sewing + sealing = 8 hours per part.

250 parts = 250 days (considering only one worker)

4 workers are considered for this activity - 62,5 days

The float's sewing process to the neoprene is also considered in this time frame.

The following items have been studied trying to imitate the movements that the worker has to do to realize the different steps. Adding more time than the necessary to realize the different actions. Thinking if the worker will need to use one or both hands, prepare something before, if the piece has to have an specific position, etc.

Assembly process:

Placing the following elements in the case:

Battery - 4 seconds

Battery receptor - 4 seconds

Connecting the battery to the receptor - 3 seconds

Placing the Arduino - 4 seconds

Connect C-type connector to the Arduino - 3seconds

Valve - 5seconds

Parts in between valves (screw in) - 6 seconds

CO₂ capsule (screw in) - 6 seconds

Tube's thread adapter (screw in) - 6 seconds

Place the cable's exit part - 3 seconds

Connect the tube with the float - 6 seconds

Add the outcoming cables from Arduino (prepare welding + weld 3 cables) - 120 seconds

Snap close the case - 8 seconds

Total =178 seconds → 3 minutes

250 parts - 750 minutes = 12.5 hours

Touch sensors:

Place the sensors (adhesive) - 20 seconds

Connect required wiring to the sensors (prepare welding + weld 2 cables) 90 seconds

Total = 110 seconds

250 parts → 27500 seconds = 7,64 hours. More or less 1 day of work.

Earbud part:

Place the vibrating part for bone communication - 6 seconds

Place the pulse-oximeter leds - 12 seconds

Place the pulse-oximeter's sensor - 6 seconds

Wiring and connecting all these parts (prepare + welding 3 pieces) - 120 seconds

Total = 144 seconds

250 parts - 36000 seconds = 10 hours.

Appendix 19: Supplies

Neoprene	https://www.etissus.com/es/neopreno-scuba/3955-neopreno-negro.html https://www.telas.es/70-0692-999_tela-de-buceo-crepe-ligera-negro.html https://www.galeriasmadrid.es/telas/telas-vestir/fiesta/tela-neopreno/
ABS	http://www.airesa.es/plasticos.html
Termoadhesive	https://www.amazon.es/Neopreno-termoadhesiva-neopreno-Reparaci3n-pegamento/dp/B01GV7U8IE https://www.ebay.es/i/293209962862?chn=ps&norover=1&mkevt=1&mkrid=1185-146825-5486-0&mkcid=2&itemid=293209962862&targetid=489283352060&device=c&mktype=pla&googleloc=1005545&poi=&campaignid=1670809419&mkgroupid=66166821833&rlsatarget=pla-489283352060&abclid=1139526&merchantid=7671260&gclid=Cj0KCOjw5z5sBRD8ARIsAJfl4BjFseCnuRMKWjAPWEIJ8Dm2Ok9Lo-Q756d04hJw34-t5qEuJ7mNOk8aAvclEALw_wcB
Zipper	https://merceriasarabia.com/224-cremallera-continua https://www.telas.es/mas-cierres-de-cremalleras-divisibles.html
Rack Zipper	https://merceriasarabia.com/carros-de-cremallera/10210-carros-cremallera-continua-nylon-8mm.html https://www.amazon.es/Cremallera-Reparador-Reemplazos-Reparaci3n-Manualidades/dp/B0794SFX96/ref=sr_1_18?keywords=cursor+cremallera&qid=1569063188&s=gateway&sr=8-18
Button	https://www.manomano.es/p/suelo-goma-circulos-3-mm-x-1-m-precio-m-lineal-7296227?product_id=7568492 https://www.importacionesmugar.es/es/circulos/pavimento-pvc-circulos-1mm-y-ancho-150m-color-negro-lestare-358231?gclid=Cj0KCOjwJfsBRDUARIsAIDHsWrNIsvqZUZ3QTHjvZmt3AAOpy5HBLYPd7dMJdCnAFVZN8XafKKoHGQaAhOaEALw_wcB
Float	https://spanish.alibaba.com/product-detail/ce-approved-inflatable-life-jacket-portable-life-vest-jacket-60810764498.html?spm=a2700.8699010.normalList.79.3899271fAZufMG https://spanish.alibaba.com/product-detail/marine-solas-auto-inflatable-lifejacket-with-ccs-ec-certificate-817122286.html?spm=a2700.8699010.normalList.133.64dd271fpNqKrZ
Arduino	https://www.tiendatec.es/115-arduino https://www.tiendatec.es/arduino/placas/379-placa-uno-r3-atmega328p-cable-usb-compatible-arduino-uno-r3-8403790020005.html
CO₂ Capsule	https://spanish.alibaba.com/product-detail/ce-certificated-33g-co2-cartridge-for-inflatable-life-jacket-60314218309.html?spm=a2700.8699010.normalList.79.63fe25caVAy9Pz

Wiring	https://www.automation24.es/cable-unipolar-negro-100-m-lapp-4510011-h05v-k-1x0-5-bk
Valve	https://www.banggood.com/es/12-34-1-Inch-220V-Electric-Solenoid-Valve-Pneumatic-Valve-for-Water-Air-Gas-Brass-Valve-Air-Valves-p-1327193.html?rmmds=detail-left-hotproducts_13&ID=518499&cur_warehouse=CN
Thread	https://www.calzadoydeporte.com/gutermann-hilo-tera-30-300-metros.html?gclid=Cj0KCOjw5zsBRD8ARIsAJfI4Bgqd_nR6ljirT1O2j4G2-32cPiksT6KFEs7Xbt_n0Gpb8yF_Oa9WN7AaAgM0EALw_wcB
Battery	https://tienda.bricogeek.com/home/1156-bateria-lipo-3500mah-2s-25c-74v.html
Battery reciever Qi	https://es.tvc-mall.com/details/universal-type-c-qi-standard-wireless-charging-receiver-sku102000685a.html?c=EUR&utm_source=google&utm_medium=pla&utm_campaign=cse&gclid=CjwKCAjw8ZHsBRA6EiwA7hw_sSkcEwGDYN0tqTxwY2f6tB9F3DNkT7JsquNx4T3qLJLGHzg19agMMRoC53cQAvD_BwE
Velcro	https://www.amazon.es/Cinta-autoadhesiva-velcro-color-684180/dp/B01CNWVKUQ/ref=asc_df_B01CNWVKUQ/?tag=googshopes-21&linkCode=df0&hvadid=309219713675&hvpos=1o13&hvnetw=g&hvrnd=13329854162010499463&hvpone=&hvptwo=&hvqmt=&hvdev=c&hvdvcmdl=&hvlocint=&hvlocphy=1005545&hvtargid=pla-420215448142&psc=1
Type C conector	https://es.rs-online.com/web/p/products/1225099?cm_mmc=ES-PLA-DS3A--google--PLA_ES_ES_CatchAll--Ad+Group+Catch+All--PRODUCT_GROUP&matchtype=&pla-293946777986&gclid=Cj0KCOjw_absBRD1ARIsAO4_D3ulX0ZPA4PX38zf_JREwwPnj3KhhuFjvK_ua0hemL3A4e5UZyY8pUoaAi0YEALw_wcB&gclsrc=aw.ds
Touch sensor	https://www.digikey.es/product-detail/es/panasonic-electronic-components/EVQ-Q2B03W/P12932SCT-ND/762922
Packaging	https://www.cajacartonembalaje.com/cajas-de-carton/caja-de-carton-automontable-marron-44x31x13cm/
Pulsioximeter	https://www.quirumed.com/es/pulsioximetro-portatil-medidor-de-pulso-y-saturacion-de-oxigeno.html?sid=46314&currency=EUR&gclid=CjwKCAjw29vsBRAuEiwA9s-0BwlAR3Y-hASZgAoorVPvBwt3x44v9k2Aac8kby5btQlFgVy3tXB-QxoCxxMQAvD_BwE
Male threaded tube adapter	https://drifton.es/tienda-online/108-conectores-y-adaptadores/2263-espiga-a-rosca-macho-npt/?gclid=Cj0KCOjwoebsBRCHARIsAC3JP0laYbn2G-6YVv3eW7W7IT7vBwaySZwFP_Leg8SiDzFVPsCnLzbGUxTlaAqKdEALw_wcB

Chart 2.18.1 - Supplies webs

Appendix 20 : Emails with dealers

Question 1

Hola, buenos días, busco un diseño de flotador que en vez de llenarse desde una parte lateral del chaleco, se pueda diseñar para que el orificio se encuentre en la parte trasera del cuello, ¿Sería posible realizarlo? No se necesitaría ni del sistema de hinchado manual ni del silbato. Sólo se necesitaría el flotador en sí, tampoco sería necesaria la mochila donde este se encuentra.

¿Que precio estamos hablando para 500 unidades? ¿ Y para 1000? ¿Qué rebaja de precio estaríamos considerando?

Muchas gracias por su tiempo, saludos.

Answer 1

Hola Este producto se puede personalizar de acuerdo a sus requerimientos. Si su cantidad es de 1000 piezas, el precio de nuestro chaleco salvavidas es de \$ 16.7. BR
Ashley

Hello our 33g CO₂ cartridge is USD2.8/PC based 1000pcs for 2000pcs is USD2.7/PC
best regards jarod gui seaman

Question 2

Buenas tardes, querría saber is hacían hebillas de 50mm y de qué precio estaríamos hablando. Muchas gracias

Answer 2

Si que las realizamos. Hablamos de un precio de 0,015\$ si se realizan 500 unidades y 0,010\$ a partir de las 1000 unidades. Saludos

Appendix 2.21 : Molds cost

The area that is being considered in order to create this budget is that of 935,28 cm³.

However, all the different parts of this design add up to a total area of 543,9 cm³.

The manufacturing price of the mold would be the same, but its dimensions would not; it would be around 50% smaller. Therefore, a final mold price is deduced to be 2,300 pounds = 2500 € per mold.

ProtoQuote[®]

Presupuesto Moldeo por Inyección

Preparado para: **ABC Design Co.**

Proceso: **Moldeo por inyección de plásticos**

Número de presupuesto: **43085**

Fecha del presupuesto: **7-Oct-2019**

Nombre de la pieza: **Folding sample part UK rev1**

Dimensiones: **250.216 mm x 194.826 mm x 19.05 mm**

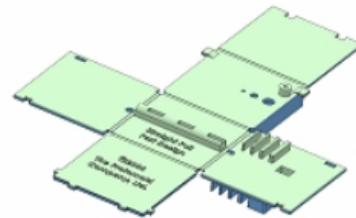

① Confirmar o modificar las especificaciones y revisar precios

Cavidades:	<input type="text" value="1 cavidad"/>	
Acabado de la cara A (verde):	<input type="text" value="PM-F1 (Cosmético bajo – se han eliminado la mayoría de la"/>	
Acabado de la cara B (azul):	<input type="text" value="PM-F1 (Cosmético bajo – se han eliminado la mayoría de la"/>	
	Precio del Molde:	£4,256.00
Cantidad muestra:	<input type="text" value="25"/>	piezas de Muestra 25 @ £1.83: £45.75
Material:	<input type="text" value="ABS, Black (Polylac PA-717C Black)"/>	
	<input type="text" value="Cambiar el color del material"/>	
	El material seleccionado no es compatible con el añadido de colorantes	
Plazo de Fabricación :	<input type="text" value="Envío de piezas de muestra - 15 días laborables (precio est:"/>	

Total (sin IVA) GBP: £4,301.75

Image 2.20 - Mold cost

3. BLUEPRINTS



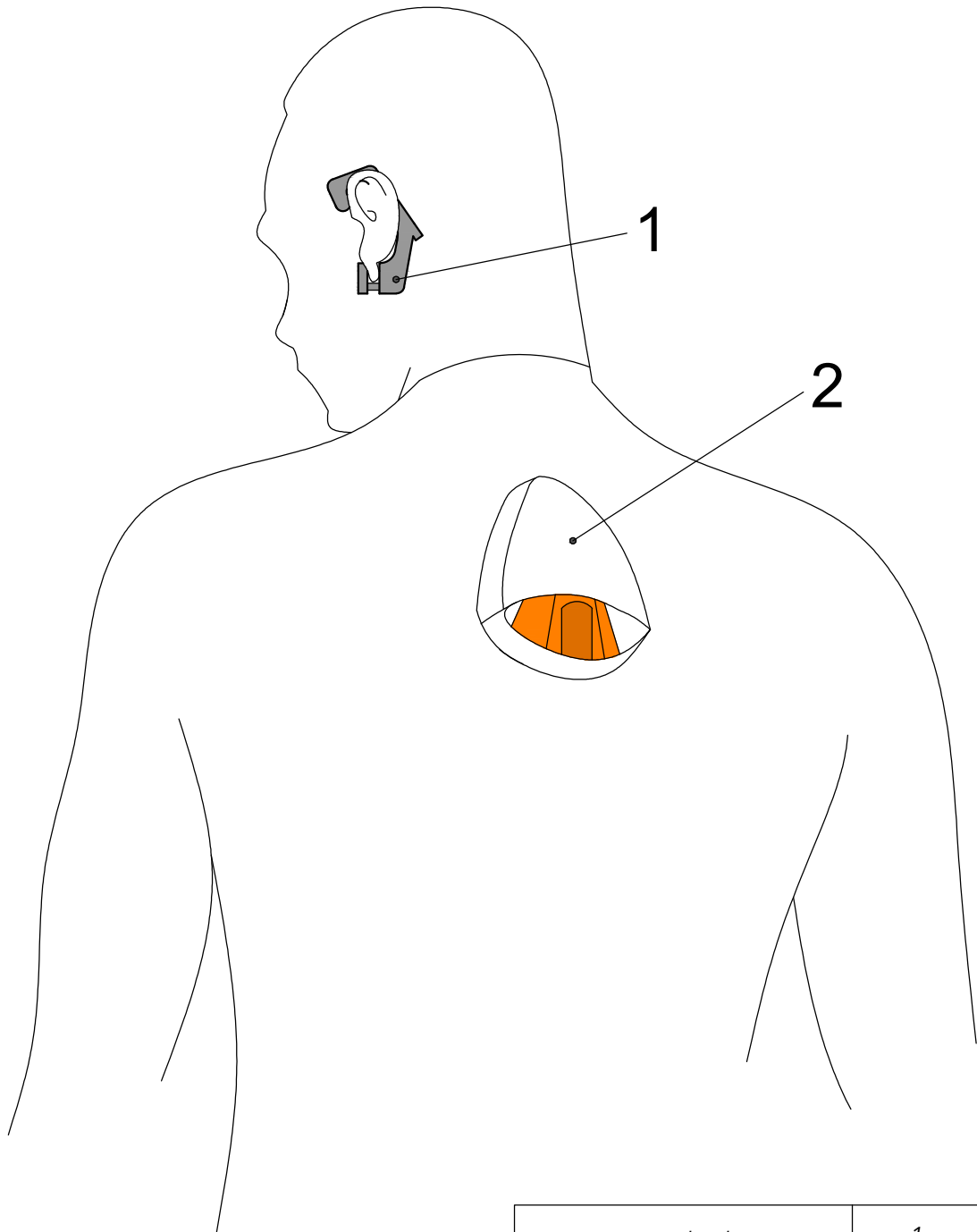

Blueprint's Index:

Set	Blueprint 1
Earbud	Blueprint 2
Earbud Set- Piece 1.....	Blueprint 3
Earbud Set - Piece 2.....	Blueprint 4
Earbud Set - Piece 3.....	Blueprint 5
Earbud Set - Piece 4.....	Blueprint 6
SCC - Principal case.....	Blueprint 7
SCC - Back case.....	Blueprint 8
SCC - Piece inside the valve.....	Blueprint 9



<i>Earbud</i>	<i>1</i>	<i>2-3-4-5-6</i>
<i>SCC</i>	<i>2</i>	<i>7-8-9</i>
<i>Name</i>	<i>Number</i>	<i>Blueprint n°</i>

<i>Degree</i> IDPDE	<i>Scale</i> --	<i>Title</i> Set	<i>Unit</i> --	<i>Paper size</i> A4
		<i>System</i>	<i>Date</i> 15-09-19	<i>Blueprint n°</i> 1
		<i>Lastname, Name</i> Peris Miralles, Lluís	<i>Responsible teacher</i> Octavio Bernad Ros	

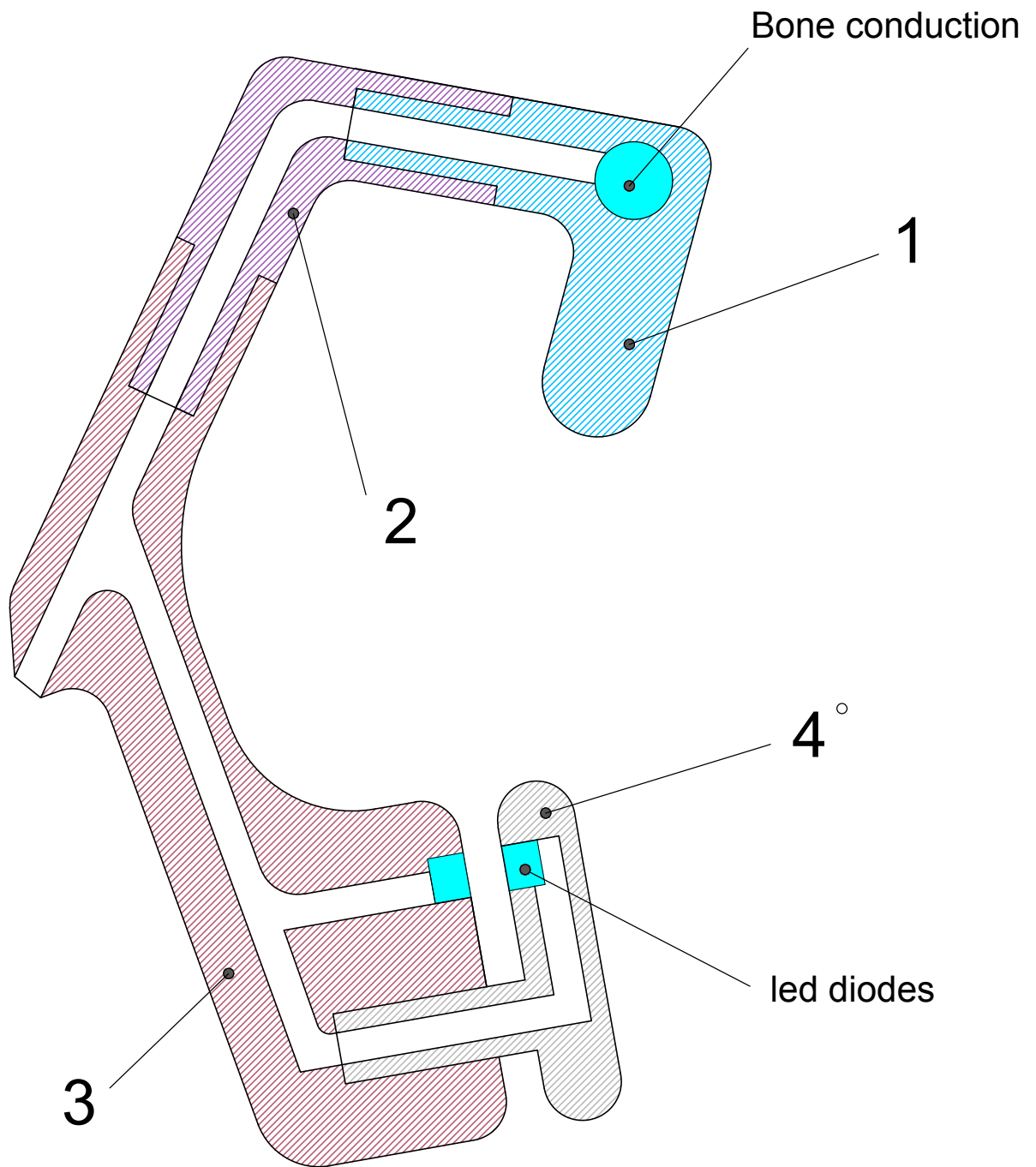

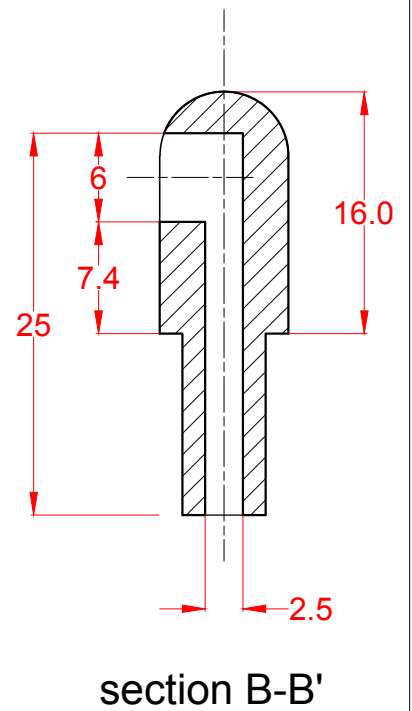
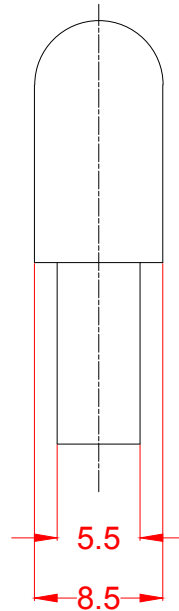
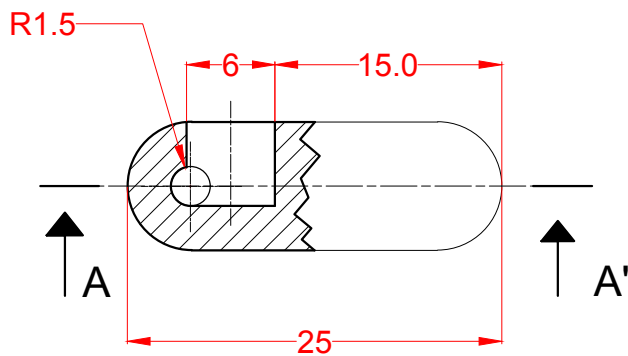
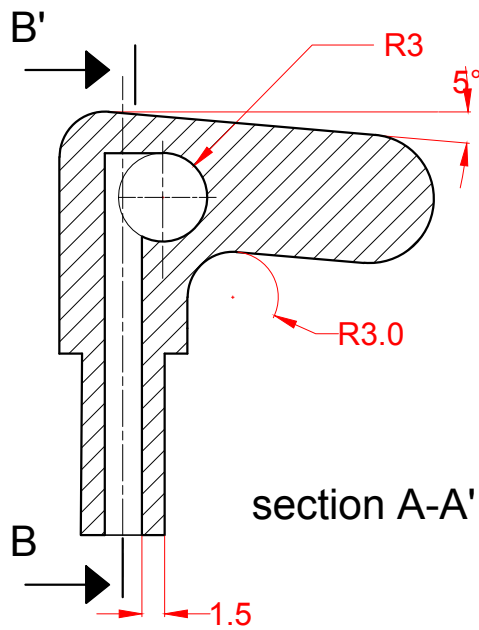
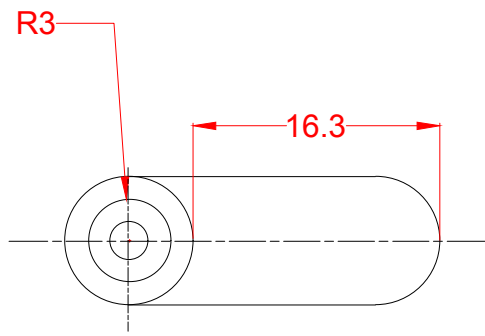

<i>Earbud - piece 1</i>	1	2
<i>Earbud - piece 2</i>	2	3
<i>Earbud - piece 3</i>	3	4
<i>Earbud - piece 4</i>	4	5
<i>Name</i>	<i>Number</i>	<i>Blueprint n°</i>

<i>Degree</i> IDPDE	<i>Scale</i> 2:1	<i>Title</i> Earbut set	<i>Unit</i> mm	<i>Paper size</i> A4
		<i>Lastname, Name</i> Peris Miralles, Lluís	<i>Date</i> 15-09-19	<i>Blueprint n°</i> 2
		<i>Responsible teacher</i> Octavio Bernad Ros		



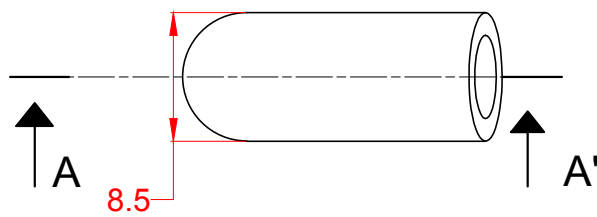
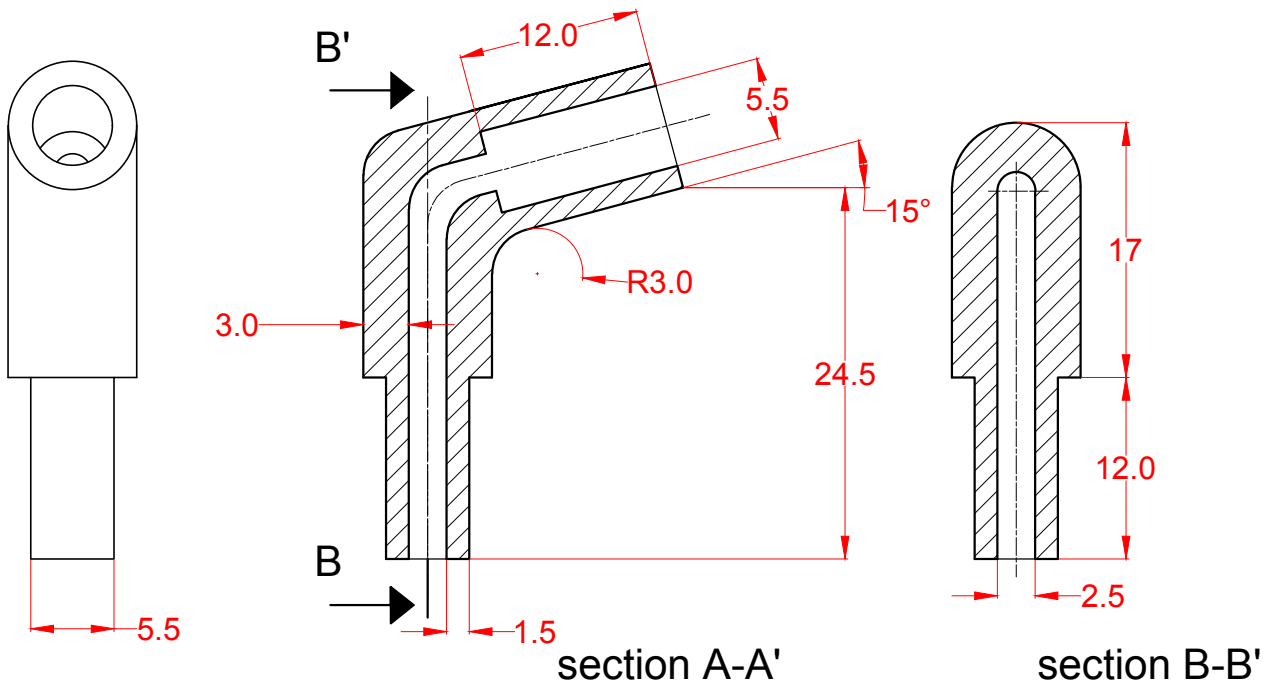
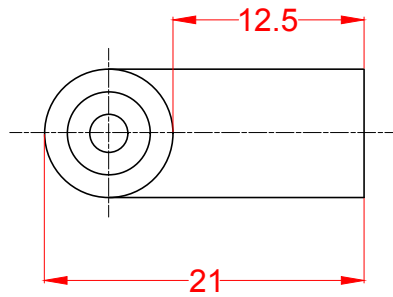

Degree IDPDE	Scale 2:1	Title Earbut set - Piece 1	Unit mm	Paper size A4
	System 	Lastname, Name Peris Miralles, Lluís	Date 15-09-19	Blueprint n° 3
		Responsible teacher Octavio Bernad Ros		



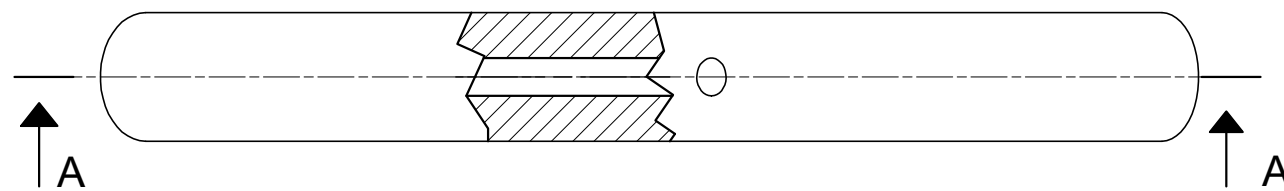
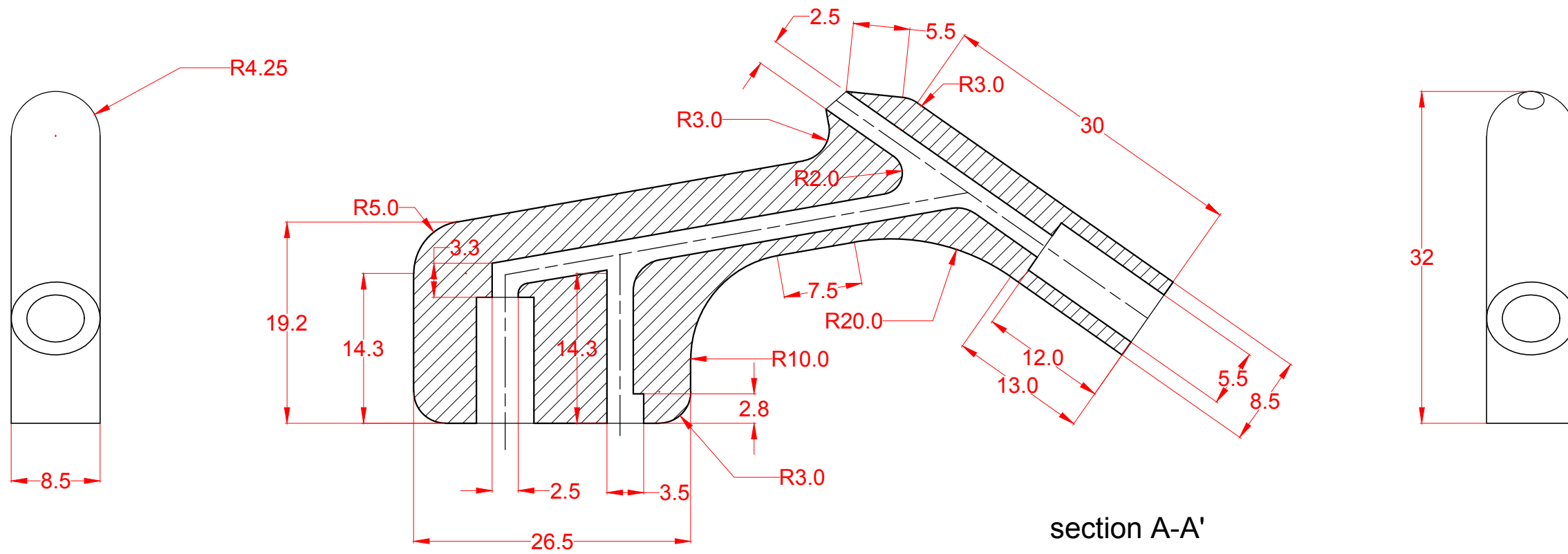
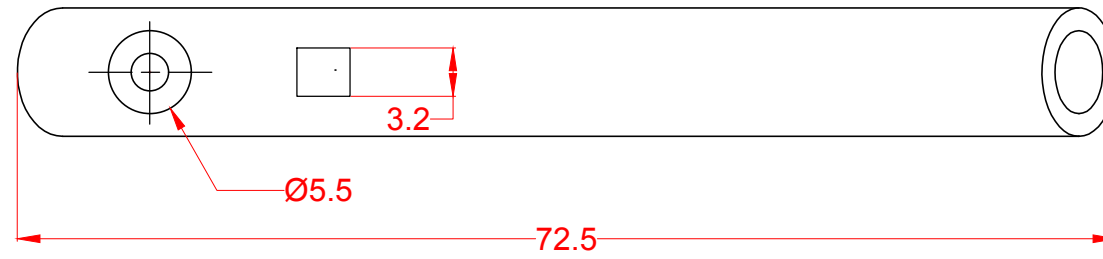

Degree IDPDE	Scale 2:1	Title Earbut set - Piece 2	Unit mm	Paper size A4
	System 	Lastname, Name Peris Miralles, Lluís	Date 15-09-19	Blueprint n° 4
		Responsible teacher Octavio Bernad Ros		



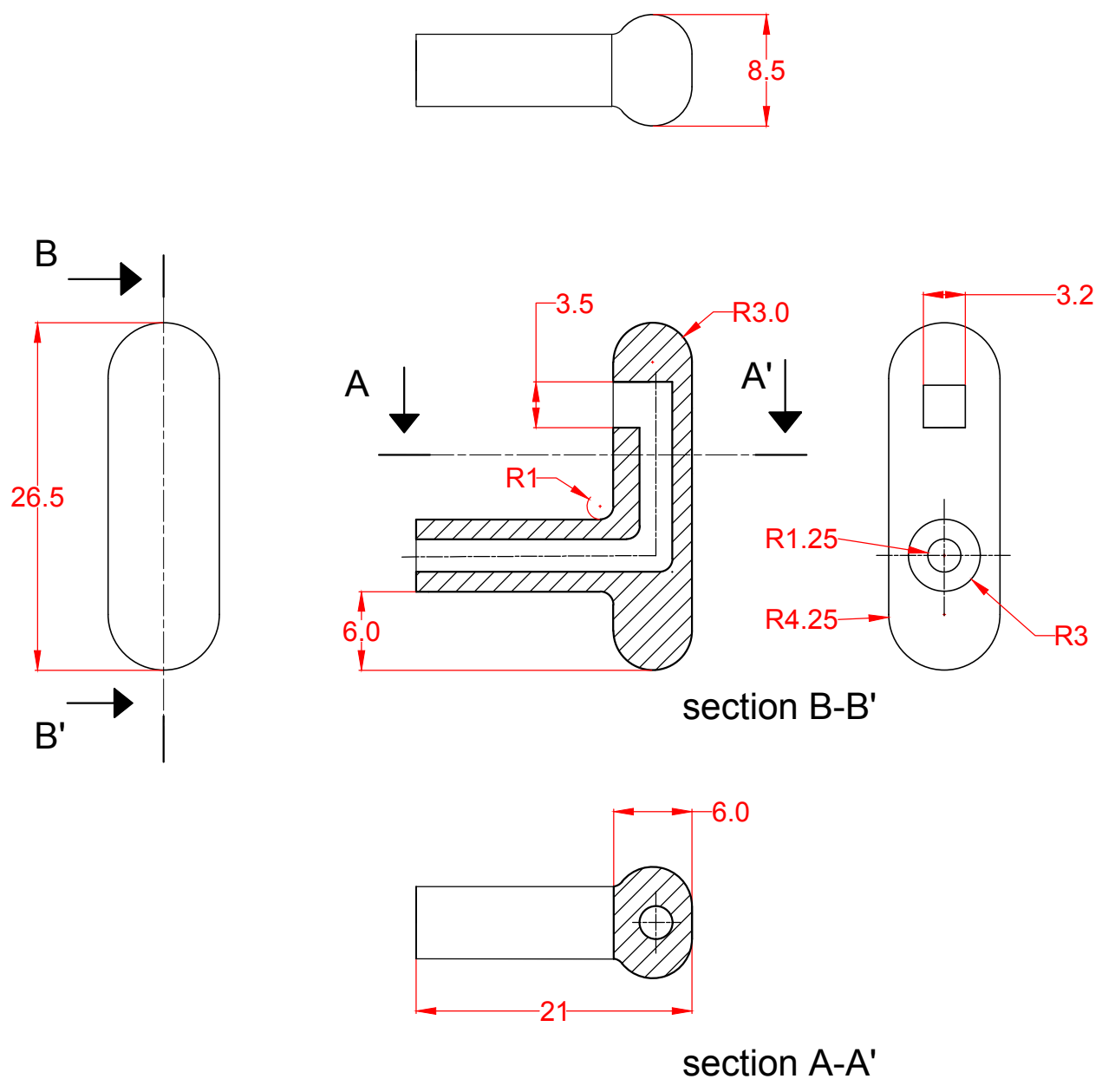

Degree IDPDE	Scale 2:1	Title Earbud - Piece 3	Unit mm	Paper size A3
	System 	Lastname, Name Peris Miralles, Lluís	Date 15-09-19	Blueprint n° 5
		Responsible teacher Octavio Bernad Ros		



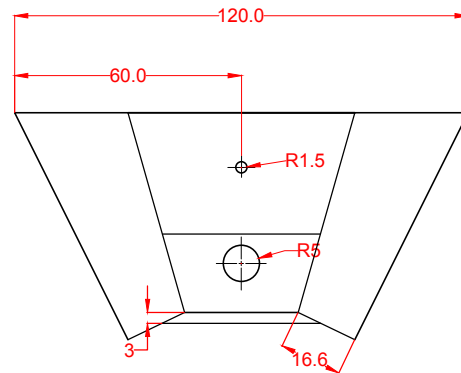
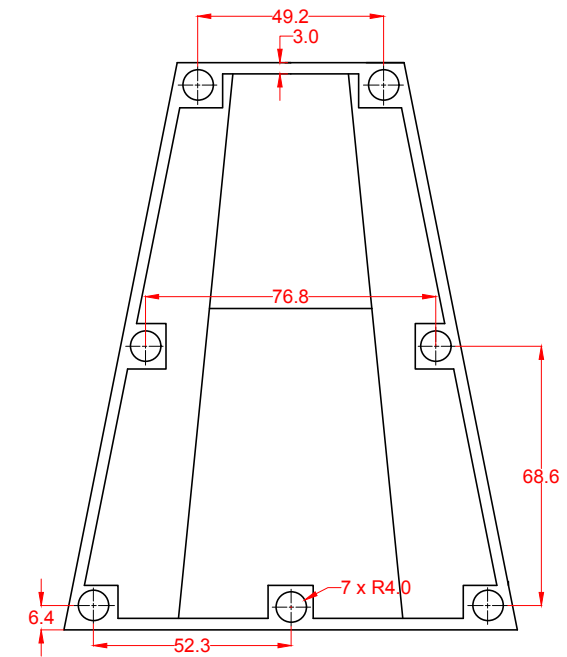
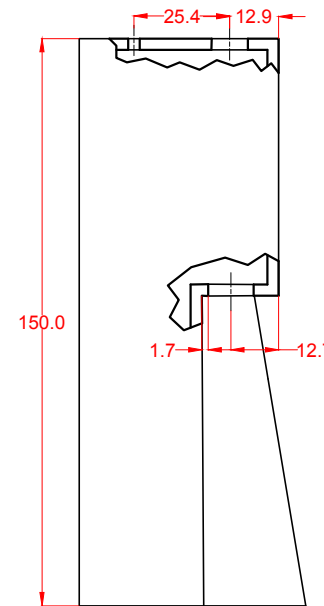
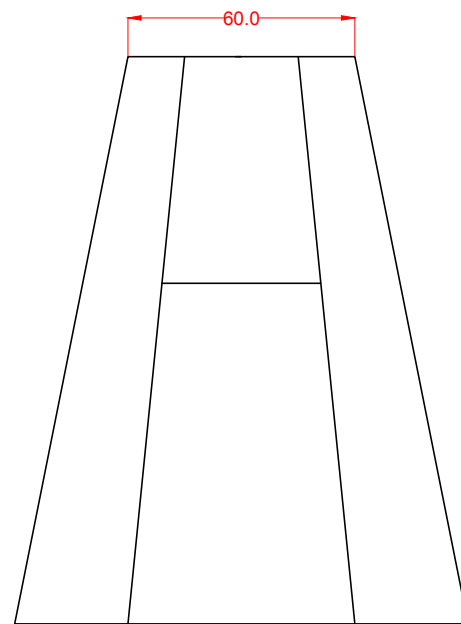
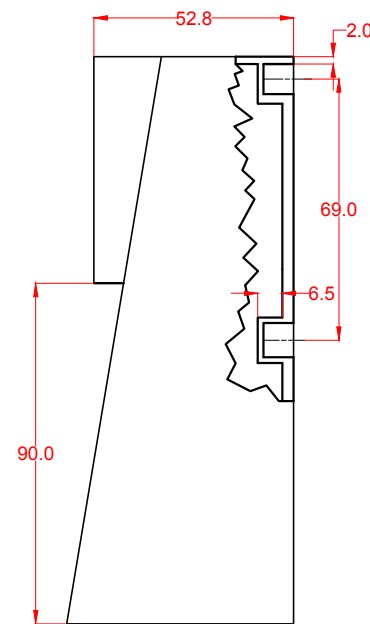
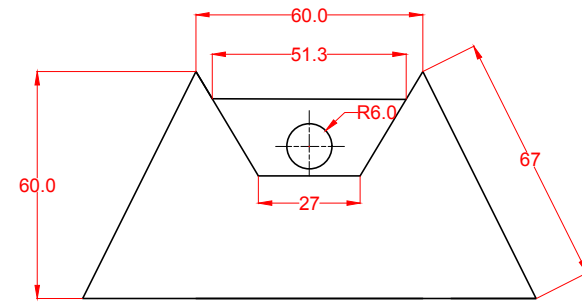

Degree <i>IDPDE</i>	Scale <i>2:1</i>	Title <i>Earbut set - Piece 4</i>	Unit <i>mm</i>	Paper size <i>A4</i>
	System 	Lastname, Name <i>Peris Miralles, Lluís</i>	Date <i>15-09-19</i>	Blueprint n° <i>6</i>
		Responsible teacher <i>Octavio Bernad Ros</i>		



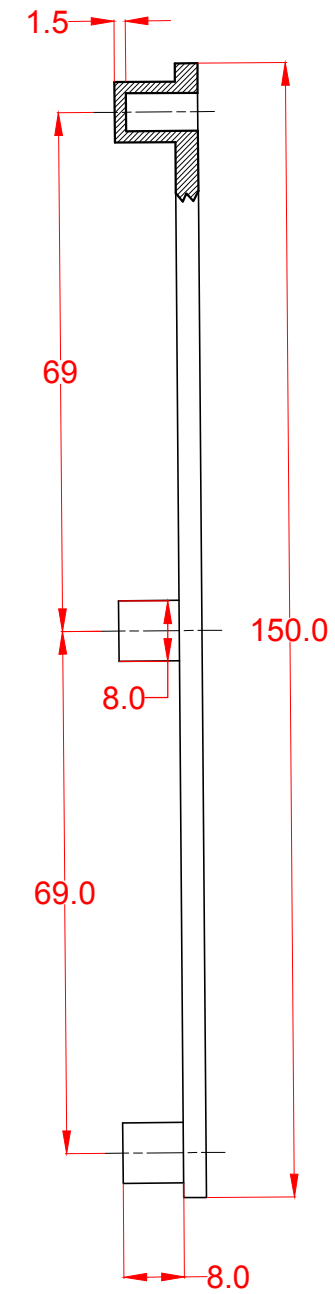
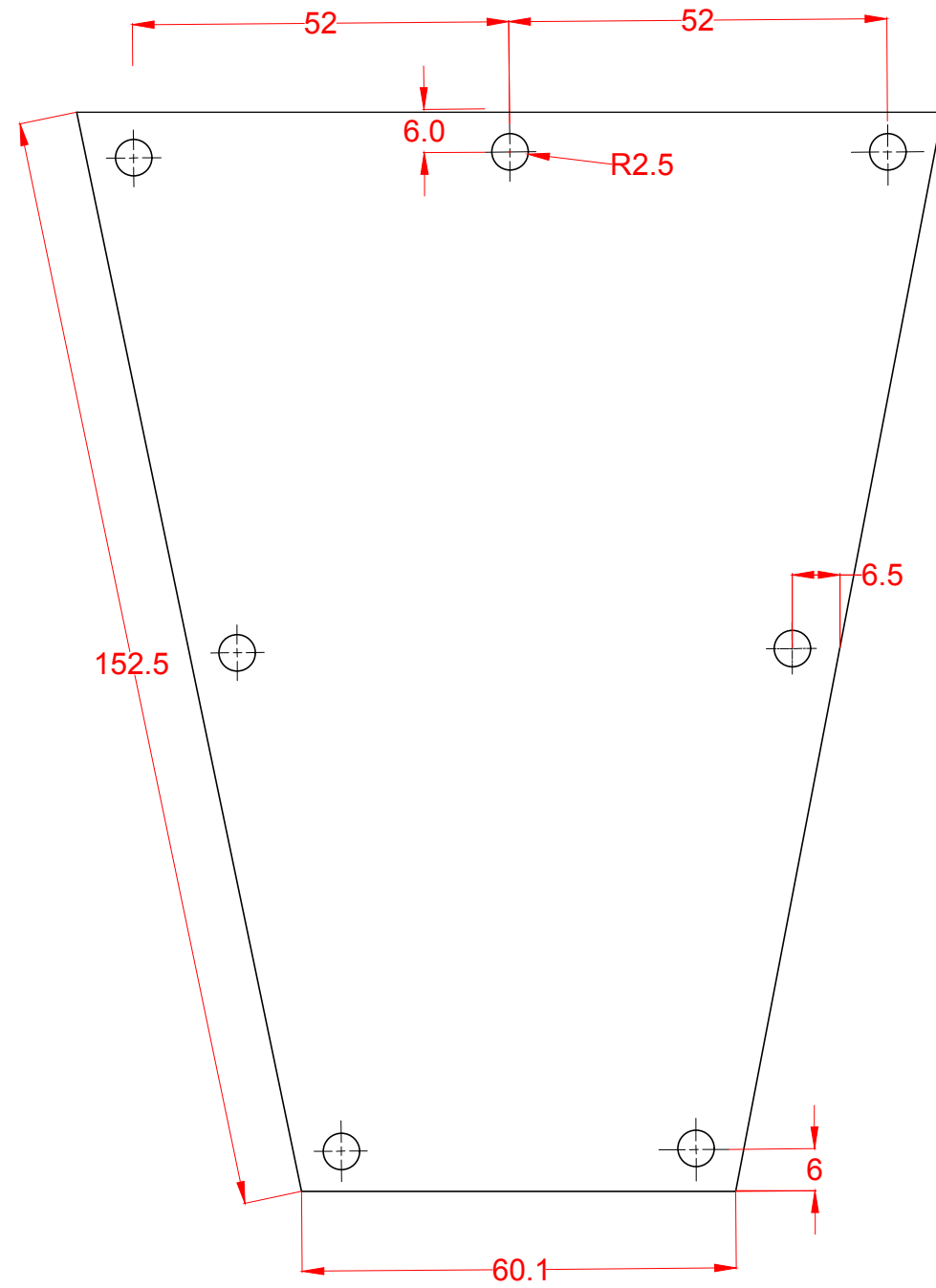
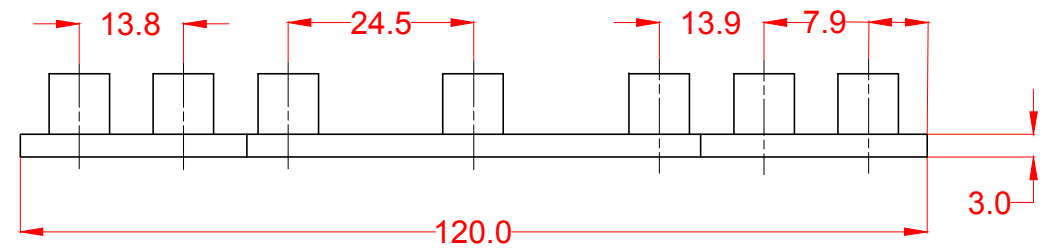

Degree IDPDE	Scale 1:2	Title SCC - Back case	Unit mm	Paper size A3
	System 	Lastname, Name Peris Miralles, Lluís	Date 15-09-19	Blueprint n° 7
		Responsible teacher Octavio Bernad Ros		

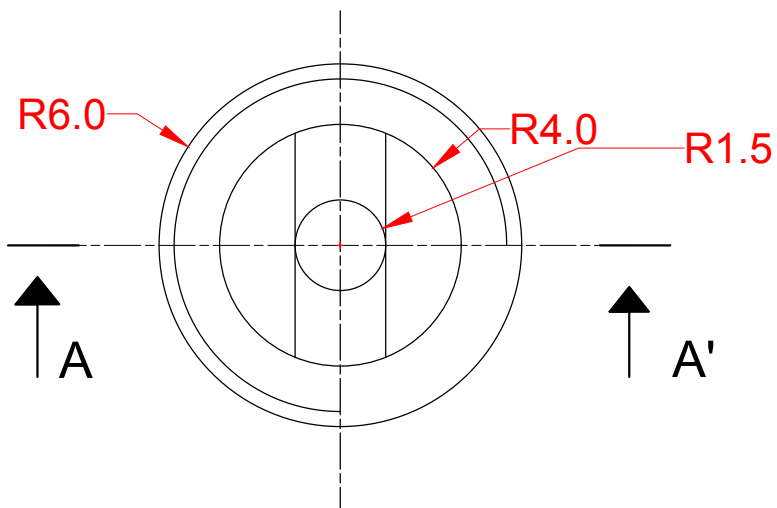
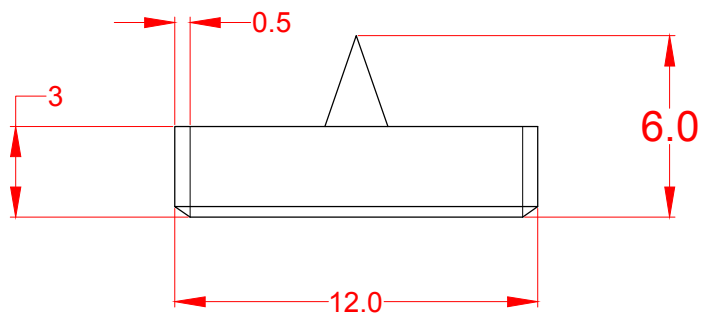
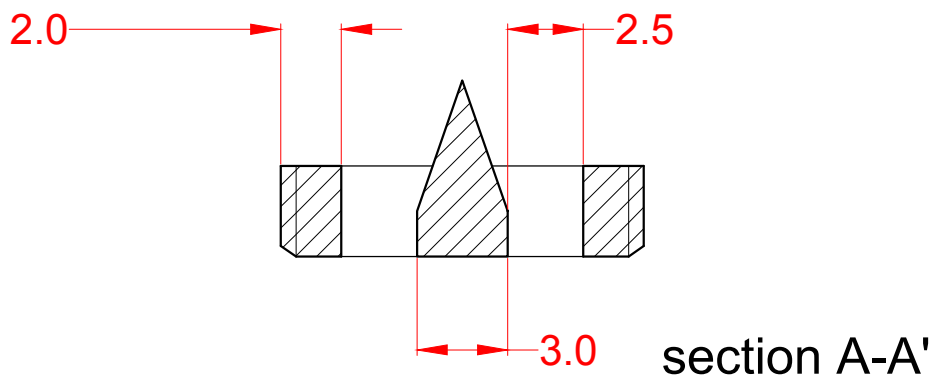

Degree IDPDE	Scale 1:1	Title SCC - Back case	Unit mm	Paper size A3
	System 	Lastname, Name Peris Miralles, Lluís	Date 15-09-19	Blueprint n° 8
		Responsible teacher Octavio Bernad Ros		



Degree IDPDE	Scale 4:1	Title SCC - Piece inside the valve	Unit mm	Paper size A4
		System System	Date 15-09-19	Blueprint n° 9
		Lastname, Name Peris Miralles, Lluís Responsible teacher Octavio Bernad Ros		

4. CONDITIONS



Condition's index

4.1 Material description and purchased elements	147
4.1.1 Purchased elements	147
4.1.2. Manufacturing elements	154
4.1.3 Joining systems	155
4.1.4 Minimum acceptable quality standards	155
4.2 Technical specifications of materials	156
4.3 Tolerances	156
4.4 Manufacturing requirements	157
4.4.1 Supplies	157
4.5 Assembly specifications.....	159
4.6 Specifications during the product operation	159
4.6.1 Usage	159
4.6.2 Maintenance	159
4.6.3 End of useful life	160

This section of the project will show the technical, economical and administrative conditions needed to fully understand the product and be able to create it with no problems. Therefore, the conditions that need to be fulfilled by the manufacturer of this product are also established in this section.

4.1. MATERIALS DESCRIPTION AND PURCHASED ELEMENTS

4.1.1 Purchased elements:

As it will be explained in the following volume, "Measurements' status" this design has a considerably large amount of purchased parts from other suppliers. These parts can be observed in the upcoming sheets, as well as the materials they are made of, and the amount required of each part.

The links to the websites in which these materials and parts will be purchased, can be found in **Appendix 18: Supplies** - Page 137.

PIECE	QUANTITY	MATERIAL
1 - Traje de Neopreno 2mm	2m (1 x 1,5m) 1m (1 x 1,5m) 2m (1 x 1,5m)	Neopreno - 2mm N. Extra elástico - 2mm Neopreno - 1mm



Image 4.1.1.1 - Wetsuit

PIECE	QUANTITY	MATERIAL
2 - Thread	1	Hilo de torzal



Image 4.1.1.2 - Thread

PIECE	QUANTITY	MATERIAL
3 - Termoadhesive	1	Termoadhesivo



Image 4.1.1.3 - Termoadhesive

PIECE	QUANTITY	MATERIAL
4 - Zipper	1 - 40 cm 1 - 20 cm	Nylon



Image 4.1.1.4 - Zipper

PIECE	QUANTITY	MATERIAL
5 - Rack zipper	2	Nylon



Image 4.1.1.5 - Rack zipper

PIECE	QUANTITY	MATERIAL
6 -Button (for the neoprene)	1	PVC



Image 4.1.1.6 - Button

PIECE	QUANTITY	MATERIAL
7 - Float	1	Polyester



Image 4.1.1.7 - Float

PIECE	QUANTITY	MATERIAL
8 - Arduino	1	—



Image 4.1.1.8 - Arduino

PIECE	QUANTITY	MATERIAL
9 - Battery	1	Polymer - Lithium



Image 4.1.1.9 - Arduino

PIECE	QUANTITY	MATERIAL
10 - Battery receiver Qi	1	—



Image 4.1.1.10 - Battery receiver

PIECE	QUANTITY	MATERIAL
11. Valve	1	Latón and PP



Image 4.1.1.11 - Valve

PIECE	QUANTITY	MATERIAL
12 - Cápsula de CO ₂	1	Steel



Image 4.1.1.12 - CO₂ capsule

PIECE	QUANTITY	MATERIAL
13 - Cable	5 m	Ext : PVC



Image 4.1.1.13 - Cable

PIECE	QUANTITY	MATERIAL
14 - Velcro	1 m	Doble cara Nylon



Image 4.1.1.14 - Velcro

PIECE	QUANTITY	MATERIAL
15 - Touch sensor	2	-



Image 4.1.1.15 - Touch sensor

PIECE	QUANTITY	MATERIAL
16 - Type C conector	1	Inoxidable steel



Image 4.1.1.16 - Type C conector

PIECE	QUANTITY	MATERIAL
17 - male threaded tube adapter	1	Acetal Copolymer



Image 4.1.1.17- male threaded tube adapter

PIECE	QUANTITY	MATERIAL
18 - Microphone	1	-

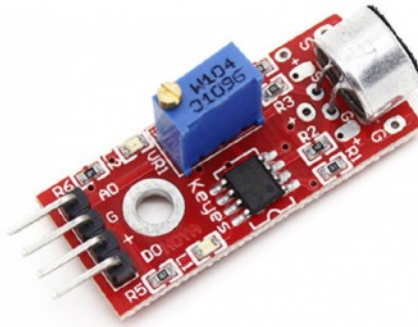

Image 4.1.1.18 - Microphone

4.1.2.Manufacturing elements:

PIECE	QUANTITY	MATERIAL
1 - SCC case (Piece 1)	1	ABS

PIECE	QUANTITY	MATERIAL
2 - SCC case (Piece 2)	1	ABS

PIECE	QUANTITY	MATERIAL
3 - Piece between valve and CO ₂ capsule	1	ABS

PIECE	QUANTITY	MATERIAL
4 -Earbud (Piece 1)	1	ABS

PIECE	QUANTITY	MATERIAL
5 -Earbud (Piece 2)	1	ABS

PIECE	QUANTITY	MATERIAL
6 -Earbud (Piece 3)	1	ABS

PIECE	QUANTITY	MATERIAL
7 -Earbud (Piece 3)	1	ABS

PIECE	QUANTITY	MATERIAL
7 -Earbud (Piece 4)	1	ABS

Charts 4.1.2.1 - Manufacturing elements

4.1.3 Joining systems:

Considering all the materials shown in section 4.1.1, the joining systems for the different parts of this project are the following:

- **Sewing;** For the neoprene suit, using twine thread.
- **Velcro-type tape;** For the float openings, and the manual hitch. (No estoy muy seguro de esta última palabra)
- **Thermoadhesive;** Will be used to glue the seals on the seams.
- **Zipper;** Pull together and close both parts of the neoprene suit.

4.1.4 Minimum acceptable quality standards

Regarding the pieces made by this company:

- In the Velcro-type tape unions, check that water cannot go from one side of the suit to the other one.
- Make sure that water cannot pass through the sewed and sealed unions.
- Once the case has been manufactured, check that both parts are perfectly well adjusted.
- The alert sound emitted by the Arduino when the user is in an emergency, must be heard at least from a 1 meter distance.

Regarding the purchased elements to external distributors:

- Check that all zippers can be easily opened and closed.
- Make sure the buckles can be easily and correctly opened and closed.
- Fill the float with water, and check there is no hole through which air can escape.
- Make sure the pulsometer is properly working.
- Check the correct operation of all sensors.

4.2. TECHNICAL SPECIFICATIONS OF MATERIALS

For those parts that will need to be manufactured, ABS was chosen as its raw materials. The rest of the parts are already purchased with pre-determined materials.

The main characteristics of ABS are:

- Rigidity
- Hardness
- Great stability and resistance to impacts and vibrations
- Low water absorption

The disadvantage of ABS is that it deforms when exposed to the sun, but it was selected because those parts will be protected by a neoprene layer, so they will not really be exposed.

4.3. TOLERANCES

Tolerances have been selected considering the type of material from which the part will be made of, its fabrication process, and its specifications. For parts manufactured through injection molding with ABS, only some dimensions have a specific tolerance. In the earbuds, all the pieces has adjustment of H6p6 and with the SCC case, between the two pieces exist a tolerance of a pressure adjustment of H5n5. This tolerances have been explained in the **Appendix 2.9 Calculation** - Page 100.

Those dimensions that have no specific requirements will have a tolerance of $\pm 0,21$ mm, an average precision that does not make production any more expensive.

4.4. TECHNICAL SPECIFICATIONS OF MANUFACTURING

The manufacturing process used for this project's parts is the plastic injection molding. It is a semi continuous process that consists on the following: The broken polymer, pellet, is placed in an upper funnel in the injection molding machine. The required amount of material is introduced in the cylinder. It then travels to the hot chamber, where the thermoplastic becomes a viscous liquid. Due to pressure effects, the liquid is passed to the mold, where the cavity gets completely filled up. The mold cools down while the pressure is sustained, and that is how the material acquires the desired shape. The final part is obtained by opening the mold and taking it out the cavity.

The cooling time of thermoplastics is almost immediate, and that is why the fabrication speed is high.

Through this fabrication process, versatile and rapidly manufactured parts, as well as very complex geometries can be obtained. It does not require finishing operations, for the parts end up with the mold's roughness, that is, the required one. These parts would only need to be polished if either the partition line or the punches' marks needed to be removed. Very complex parts with fairly strict tolerances can be obtained. The tooling cost is extremely high, so it is convenient to use it for large batches.

4.4.1 Supplies:

The following table shows the required data to adapt the cost, time, and parts' quantities to the manufacturing techniques:

PIECE	QUANTITY per suit	TIME TO ARRIVE	MATERIAL
Neoprene 2mm	2 (1 x 1,5 m)	7 days	Neoprene
Neoprene 1 mm	2 (1 x 1,5 m)	7 days	Neoprene
Neoprene Extra elastic	1 (1 x 1,5 m)	7 days	Neoprene

PIECE	QUANTITY per suit	TIME TO ARRIVE	MATERIAL
Thread	1 - 150 m	3 days	"hilo de Torzal"
Termoadhesive	1 (35 ml)	10 days	-
Zipper	2 (40 cm + 20cm)	3 days	Nylon
Rack Zipper	2	3 days	Nylon
Velcro	80 cm	5days	Nylon - velcro both faces
Arduino	1	3 days	-
Battery	1	3 days	-
Battery receiver	1	15 days	-
Valve	1	3 weeks	Brass
Wiring	1,5	3 days	PVC
PVC buttons	1	8 days	PVC
Tipe C conector	1	3 days	Copper alloy
Bone transmission system	1	1 week	-
Pulsioximeter	1	2 weeks	-
Touch sensor	1	7 weeks	Polyamide - nylon
Float device	1	5 days	Polyester
Microphone	1	3 days	-

Charts 4.4.1.1 - Supplies

All the links to the suppliers' websites or the purchasing web locations for the supplies can be found in **Appendix 18: Suppliers** - Page 137. And some emails with the dealers, **Appendix 19** - Page 139.

Moreover, some of the questions made to the distributors regarding their products, prices, and specific needs for this product, can be found in this same appendix.

4.5. ASSEMBLY SPECIFICATIONS

The company will be responsible for both a proper operation of the mechanisms that integrate the design, as well as the manufactured parts. However, it will take no responsibility for possible failures or malfunctioning of the purchased elements. All these situations will need to be evaluated by technical personnel, and all the corresponding quality certificates will also need to be included. The assembly order can be found in section **1.8.5 Assembly description**, in Volume 1: Report.

4.6. SPECIFICATION DURING THE PRODUCT OPERATION

4.6.1 Usage

In order to charge the device, the suit needs to be folded, leaving the back case at the upper part and taking the CCS out of its case, so it can be placed in the charging base. Once the suit has been put on, the device will be turned on by pushing one of the left shoulder's buttons; a "Piii" sound will be immediately emitted, indicating the device is now on. If this sound was not heard, it would mean that one of the sensors is not fully contacting the user's body.

If this device emits the following intermittent sound "pii - pii - pii", that means the battery is about to run out.

On the other side, if ALL the sensors failed and the 5 seconds countdown started with the non-intermittent sound "Pii", the user would have these 5 seconds to push the left shoulder button in order to let the system know everything is fine, otherwise the float would be automatically inflated.

4.6.2 Maintenance

- Charge the device hours before performing the activity.
- In case the float was user, replace the CO₂ capsule.
- Hang the suit after being used so it can properly dry.
- Keep the suit in a dry spot in order to optimize its durability.

4.6.3 End of useful life

Plastics take from 100 to 1000 years to degrade, and that is why recycling them is important. In this case, with ABS, it would be a good option that, if the plastic was broken due to an impact, it was triturated and turned into pellet again; this plastic could now become a brand-new object.

If the reason why the product came to its end of life is because of sun exposure, or simply due to time, this plastic has already lost its physical properties, which means it would be better to throw it away in the yellow container.

It must be taken in consideration there are some other materials besides plastic, just like the battery, the valve, all the wires, etc. All these elements must be separated before

5. MEASUREMENT STATUS



Measurement's Index

5.1 Cost of the purchased parts.....	165
5.1.1. Neoprene suit.....	165
5.1.2. Security.....	165
5.1.3. Electronic devices.....	166
5.1.4. Presentation.....	167
5.2 Raw material cost	167
5.3 Machinery cost	168

En este apartado se va a desglosar por temas todos los gastos necesarios para la realización del diseño:

5.1 Costs of the purchased parts:

Every required part or material will be broken down by overall price, unit price, amount needed, weight, and depending on its relevance, its dimensions too.

5.1.1. Neoprene suit:

PIECE	QUANTITY	PRICE	PRICE PER SUIT	WEIGHT
Neoprene 2mm	2 (1 x 1,5 m)	7,5 €/m	15 €	220 g/m ²
Extra elastic Neoprene	2 (1 x 1,5 m)	7,95 €/m	7,95 €	190 g/m ²
Neoprene 1mm	1 (1 x 1,5 m)	4 €/m	8 €	120 g/m ²
Thread	1 - 150 m	–	2,4 €	–
Termoadhesive	1 (35 ml)	–	1,97 €	-
Zipper	2 (40 cm + 20cm)	1 €/m	0,6 €	–
Rack Zipper	2	0,6 €/m	1,2 €	–
Velcro	80 cm	–	0,9 €	59 g
Button	2	7,8 € (1x1,5m)	0,13 €	–

Charts 5.1.1.1 - Neoprene materials

5.1.2. Security:

PIECE	QUANTITY	PRICE	PRICE PER SUIT	WEIGHT
Float	1	–	15,3 €	400 g
CO₂ Capsule	1	–	2,4 €	149 g
Loctite 406	1	10 €	1,25 €	20 g

Charts 5.1.1.2 - Security materials

5.1.3. Electronic devices:

PIECE	QUANTITY	PRICE	PRICE PER SUIT	WEIGHT / DIMENSION
Arduino	1	–	4,95 €	58,5 g
Type C conector	1	–	1,3 €	–
Touch sensor	1	–	0,12 €	24 g
Wiring	1,5 m	–	0,136 €	–
Battery	1	–	13,9 €	215 g 72x30x14 mm
Battery receiver	1	–	2,92 €	70 g 104 x 42 x 7 mm
Valve	1	–	9,9 €	240 g 60 x 40 x 75 mm
Bone transmission system	1	–	< 5 €	–
Pulsioximeter	1	–	4,75 €	–
Adaptador tubo a rosca	1	–	1,10 €	
Microphone	1	-	0,34 €	13g 40 x 15 x 13 mm

Charts 5.1.1.3 - Electronic materials

5.1.4. Presentation:

PIECE	QUANTITY	PRICE	PRICE PER SUIT	DIMENSION
Packaging	1	–	1,19 €	44 X 31 X 13 cm

Charts 5.1.1.4 - Presentation materials

5.2 Raw materiales cost:

PIECE	PRICE	PRICE PER SUIT
ABS (granza)	1,15 € / kg	0,197 €

Charts 5.2.1 - Raw materials cost

The area has been obtained by Autocad.

The density of ABS is 1,06 g/cm³.

SCC back case → Area = 494,25 cm²

e (thickness) = 3 mm = 0,3 cm

Volume = 132,075 cm³

Weight = volume x density = 140 g

Earbuds → Area = 49,64cm²

e (thickness is changing) e (average) = 6 mm = 0,6 cm

Volume = 29,784 cm³

Weight = 31,57 g

TOTAL weight = 171,57 g of ABS

5.3 Machinery cost:

PIECE	QUANTITY	PRICE
Injection molding machine	1	8700 €
Industrial iron	1	1000 €
Cosine machine	1	1500 €
"Remalladora"	1	3000 €
"Termofijadora"	1	600 €
Molds	7	2500 x 7 = 17500 €

Charts 5.3.1 - Machinery cost

Ana Martinez Iserte has explained the importance of most of this machines and how necessary are them to develop this product.

6. BUDGET



Budget's Index

6.1 Considerations.....	173
6.. Cost product per unit.....	174
6.2.1 Raw material cost.....	174
6.2.2 Purchased pieces cost.....	175
6.2.3 Workers cost.....	175
6.2.4. Manufacturing cost.....	176
6.3 PVP.....	176
6.4 Viability, annual calculation and cash flow.....	177
6.4.1 Initial investment.....	177
6.4.2 Profitability and viability.....	178

6.1 Considerations

It must be taken in consideration that this design is oriented for a clearly determined population sector: high performance aquatic athletes like sailors, kayakers, surfers, ky-surfers, paddle boarders, windsurfers, among others.

The “Exclusion calculator” program was used to create a rough idea on the physical requirements for this kind of sports. More than 10% is already excluded, and it would actually be more than that, for depending on the sport, people must have a stronger grip on their hands, they must be able to remain standing, or have stronger arms, stability, etc.

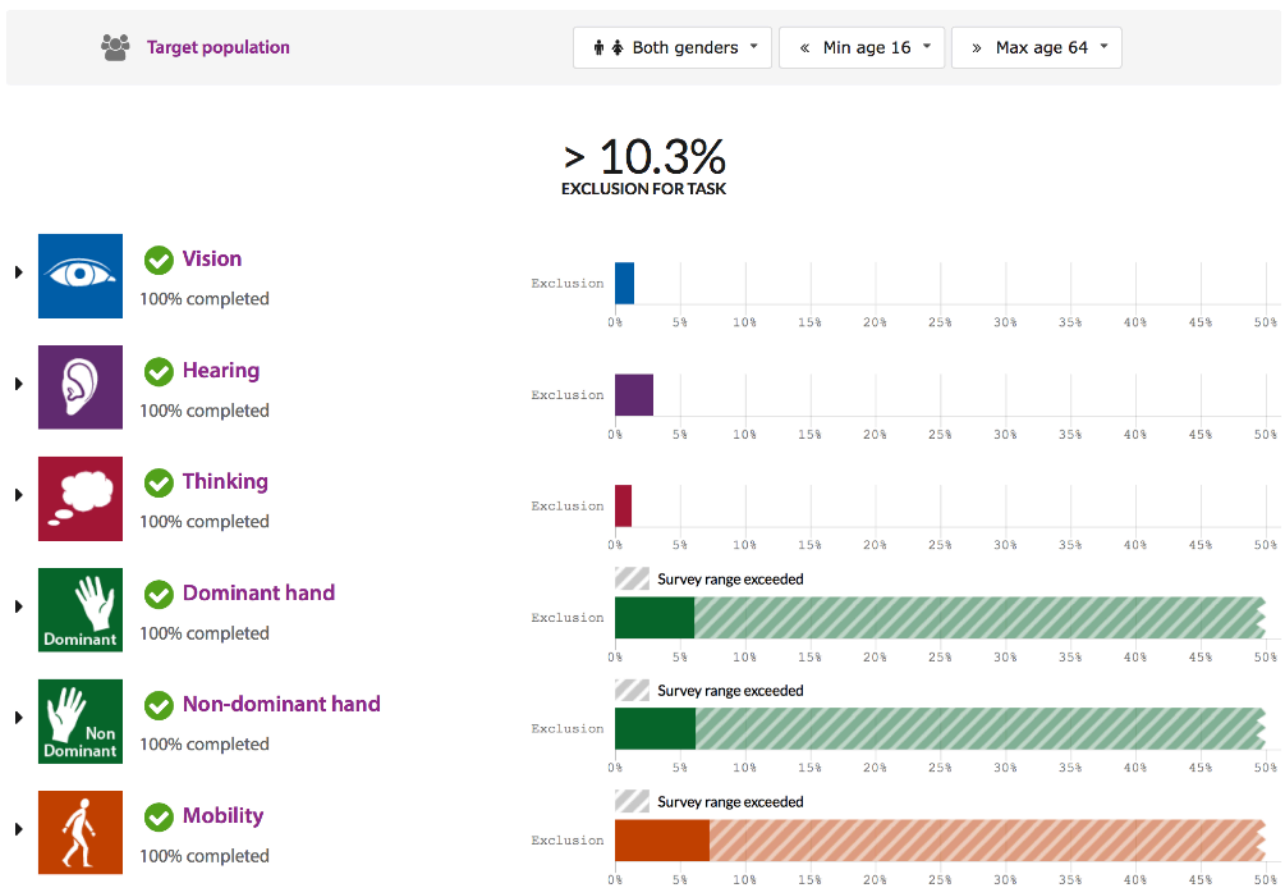

Image 6.1.1 - Exclusion calculator

In addition to the already excluded ones, a huge amount of people does not practice this kind of sports, which means the target market is small.

Having all this in consideration, it is important to highlight that this kind of athletes are commonly worried about their safety, for they can be exposed to high-risk situations. Moreover, they are willing to pay relatively high prices for this type of products, specially if those products increase their safety level.

It is established that, being an innovative product, it will experience important sales increments in the first years, being the fifth one when it will considerably decrease its sales level. Once in that point, the objective is to maintain a stable sales level, satisfying the users by improving the suit's features: reducing the different components' sizes, eliminating certain wires, making the suit lighter, adding new features (music, time...).

6.2 Cost product per unit

6.2.1 Raw material cost:

PIECE	PRICE	PRICE PER SUIT
ABS (granza)	1,15 € / kg	0,197 €

Chart 6.2.1.1 - Raw material cost

TOTAL weight = 112,25 g of ABS

This is for:

SCC back case (two pieces)

Earbuds (four pieces)

6.2.2 Purchased pieces cost:

This cost is the summation of all the costs in the charts 5.1.1 , 5.1.2 , 5.1.3 , 5.1.4.

	PRICE PER SUIT
Purchased pieces	102,706 €

Chart 6.2.2.2 - Purchased pieces cost

6.2.3 Workers cost:

All the workers must have study. So their salary will be higher than an standard operator. Comparing the salaries in a different business in this scope, the salary for the workers will be the following one:

PIECE	QUANTITY	PRICE PER HOUR	PRICE PER SUIT
Computer scientist (Alexa interface)	1	10 €	1,6 €
Molding inyección operator	1	7,5 €	0,15 €
Dressmaker	4	8,5 €	68 €

Chart 6.2.3.1 - Workers cost

Computer scientist: It was asked to an computer scientist. and t would be a work more or less for a month. 1600 € / 1000 (estimate number of suit sold at least).

Molding inyección operator. He or she will be working 72 seconds per suit. This has been calculated in **Appendix 2.17-** Page 132.

Dressmaker: He or she will be working 8 hours per suit.

6.2.4. Manufacturing cost:

The consumption price of each machine is based on an average rate of the 5 most important electric companies in the country: 0,13 €/kWh.

Machine	Uptake	Cost (1h)	Time per suit	Price per suit
Injection molding machine	70 kWh	9,1 €	72 seg	0,182 €
Industrial iron	3 kWh	0,39 €	< 1 hour	0,39 €
Cosine machine	125 Wh	0,0162 €	2 hours	0,0324 €
"Remalladora"	400 Wh	0,052 €	< 1 hour	0,052 €
"Termofijadora"	1,25 kWh	0,1625 €	< 1 hour	0,1625 €

Chart 6.2.2 - Machine cost

The time spend in every machine (for the suit) has been obtained by Ana Martinez (Dressmaker).

6.3 PVP

Direct cost	Price
Raw material	0,13
Purchased pieces	102,706
Workers	69,75
Manufacturing cost	0,8189
TOTAL	173,40 €

Chart 6.3.1 - Direct cost

	Price
Indirect cost (10%)	17,34 €
Industrial cost (direct + indirect)	190,74 €
Commercialization const (15%)	28,61 €
Comercial Cost	219,351 €
Benefit (30%)	65,80 €
PVP (without IVA)	285,15 €
PVP (with IVA 21%) <small>Chart 6.3.2 - PVP</small>	345 €

6.4 Viability, annual calculation and cash flow

Profitability is the relation between the product's net profit and the initial investment needed to create that product.

The first year's sales forecast consists of a batch of 250 units.

6.4.1 Initial investment:

PIECE	QUANTITY	PRICE
Injection molding machine	1	8700 €
Industrial iron	1	1000 €
Cosine machine	1	1500 €
Remalladora	1	3000 €
Termofijadora	1	600 €
Molds	7	2500 x 7 = 17500 €
Savings to open the business	–	10000 €

Chart 6.4.1 - Initial investment

The molds' cost has been estimated in **Appendix 2.20 - Molds' cost** - Page 140.

Finally the total initial investment it is **42300€**.

6.4.2 Profitability and viability:

Profitability = net profit / investment

Net profit = income - expense (for 5 years) = 85538,7€

Profitability = $85538,7 / 42300 = 2,02$

This means that after the fifth year, the initial investment will have been already doubled as profit.

To calculate the viability it has been supposed the following information

Inflation: 1,8%

Sales forecast for the first year: 250 units

Second and third year: 500 units

Fourth year: 350 units

Fifth year: 200 units

As it can be checked in the table, the VAN (Actual Net Value) will become positive from the second half of the second year (Year 1). From that moment, there is a profit.

	Year 0	Year 1	Year 2	Year 3	Year 4	Year 5
Investment	42300 €	–	–	–	–	–
Sold units	0	250	500	500	350	200
Expense	–	54837,75	109675,5	109675,5	76772,85	43870,2
Income	–	71287,5	142575	142575	99802,5	57030
Benefit	–	16449,75	32899,5	32899,5	23029,65	13159,8
Cash flow	–	16449,75	32899,5	32899,5	23029,65	13159,8
VAN	42300	-26013,11	6560,64	39134,4	61936,04	74965,54

Chart 6.4.2 - VAN

ACKNOWLEDGMENTS:

Nurse:

-Adriana Ahís

Doctors:

- Marta Lenguas (Student)

- Julia Cone (Student)

- Paula Ensesa (Student)

Dressmaker:

- Ana Martínez

Biomedical Engineer:

-Nadia Paulina González

Family

Project tutor

Octavio Bernad

And special mention to

Jesús Eduardo Tostado Nieto (Mechanical Engineer)

Thanks for all the help that he has given to me in this project