

Construction I, project. The look and thought on traditional building techniques

Juan A. García-Esparza

Construction I, project. The look and thought on traditional building techniques

Juan A. García-Esparza



DEPARTAMENT D'ENGINYERIA MECÀNICA
I CONSTRUCCIÓ

■ Codi d'assignatura ED0910

UNIVERSITAT
JAUME • I

Edita: Publicacions de la Universitat Jaume I. Servei de Comunicació i Publicacions
Campus del Riu Sec. Edifici Rectorat i Serveis Centrals. 12071 Castelló de la Plana
<http://www.tenda.uji.es> e-mail: publicacions@uji.es

© Del text: Juan A. García-Esparza, 2013

© De les imatges: els alumnes i les alumnes, 2013

Revisió dels textos: Fermín Font Mezquita

[Col·lecció Sapientia 78, versió en català](#)

[Col·lecció Sapientia 79, versió en anglès](#)

[Col·lecció Sapientia 80, versió en espanyol](#)

www.sapientia.uji.es

Primera edició, 2013

ISBN: 978-84-695-8049-3



Publicacions de la Universitat Jaume I és una editorial membre de l'UNE, cosa que en garanteix la difusió de les obres en els àmbits nacional i internacional. www.une.es



Reconeixement-CompartirIgual

CC BY-SA

Aquest text està subjecte a una llicència Reconeixement-CompartirIgual de Creative Commons, que permet copiar, distribuir i comunicar públicament l'obra sempre que s'especifique l'autor i el nom de la publicació fins i tot amb objectius comercials i també permet crear obres derivades, sempre que siguin distribuïdes amb aquesta mateixa llicència. <http://creativecommons.org/licenses/by-sa/3.0/legalcode>

Index

The background of this project	5	Jack vaults	34
Foundations	7	Stair vaults	36
Walls	9	Domes	39
Stresses	9	Wooden frameworks	41
Stonework	10	Floors	41
Masonry	12	Stairs	43
Ashlar Masonry	15	Roofs and Slopes	45
Sun-dried bricks and industrialized bricks	17	Roofs – Eaves	47
Rammed earth	19	Covering	49
Openings	20	Vertical Coatings	51
Windows	20	Horizontal Coatings	53
Doors	22	Singular elements	55
Balconies	24	Chimneys	55
Stoneworks arches & vaults	26	Bibliography	57
Arches	26	Authors of the drawings	57
Vaults	28		
Bricked-up arches & vaults	30		
Thrusts & counteracts	30		
Arches	31		
Vaults	33		

The background of this project

Much of the built heritage from rural and traditional areas is seriously threatened, either because of pressure from real estate leading to abandonment or because of some alterations that betray the rejection to the traditional housing among other reasons.

About 60 % of the historical sites encounter similar problems: loss of population, aging population, abandoning houses, and consequently their poor conditions and inadequacy. The result of this is the complex decreasing situation of many enclaves, in which only about 30 % are not in danger or are in a revitalization process. This means that three quarters of rural enclaves might be in a helpless situation.

For the analysis of traditional construction by means of Project Manager (PM), it is possible to use the term enclave in a broad sense in which we can bring together the different settlement classifications, almost always clustered, although sometimes it is possible to analyze some isolated building.

Enclave, therefore, means an architectonic ensemble – urban and rural – including any dwelling or disseminated construction, linked to a specific way of life or to local building traditions related to cultural landscape.

Selected enclaves for Project Manager (PM) are significant in the region to be analyzed in order to highlight the qualities together with the capacities and

to present the features from traditional construction as a result of cultural wealth both because of their inheritance value and their typological variety.

The studied housing typology especially corresponds to a compact and evolutionary house. A dwelling which joined together specialized areas with clear segregation between people and animals, between land labourers and family life; an entire housing that combines productive and residential functions.

Compact housing shows a single unit, mostly planned on rough terrain. Compact housing starts from an elementary constructive unit to which some more units are added, normally in height when they are clustered, or on the ground when they are disseminated. The house changes from a simple shelter to fulfilling multiple functions.

The most common building typology is made of a stable construction which, due to the fact of being clustered, normally has a ground floor plus two heights or even three; a factor that increases where there is shortage of land for building or terrains with steep slope angles.

With regard to the framework features, the most common solution is the one with load-bearing walls on which to lay the framework structures (timber beams with various solutions for the space between the joist) and

the roof structure (beams and joist with its pertinent elements of coverage). Also, it is possible to find different kinds of vaults in wine cellar roofs, basement floors and grounds, most of them built with stone, brick and mortar. Diaphragm or pointed arches are common as well because they serve as a construction support for short-length horizontal frames to achieve spaciousness in the housing.

In traditional construction it is common to cover the walls, especially the facade, to preserve the structural materials (stones, bricks, adobe and mortar)

of the erosive action of water. The most common material for covering is lime mortar, while gypsum plaster or clay mortars is less frequent. Ceramic tiling is not very frequent but they also exist in coastal zones, in housing exposed to marine environment. Only rear facades and party walls of some buildings may lack coatings as well as some auxiliary constructions located outside the villages.

Foundations

The foundation is the element that allows to transmit the loads which support a structure to the ground, so that it does not exceed the ground-bearing capacity and if eventual deformations occur they would be admissible for the structure.

The foundation of historic buildings, mostly superficial, was solved by means of a generic section beginning with the dumping of a quick-lime mortar layer; this served a similar function as today's cleaning of concrete, at the time serving to protect the upper layers of limestone, susceptible of being tackled by microorganisms or acid substances typical of some terrains.

When it was impossible to reach the rock or to find a sufficiently solid terrain, an intermediate layer of stone rubble mixed with lime mortar was laid out to serve as a surface or basis of foundation.

The design of running foundations, the type of foundation normally used by the kind of buildings in which we take interest now, was done weighing up to determine the subsidence pressure, the working pressure or admissible pressure and the calculation of expected ground settlements.

Damages on foundations will depend, among other factors, on the structural typology of the building and features of the terrain. They can be of several types: general breaking subsidence – fast loading and ground

settlements –, punching – compressible ground and low resistance – or by local breakage – the terrain giving way in the edges of the foundation.

Instant settlements, consolidation settlements, or creep can also happen. The origins of the damages are often due to ignorance of the behaviour of soil, because of water leaks or miscalculation among others; with possible distortion or breakage depending on the stonework resistance, inertia to bending, slenderness and curvature. In general, rock sets up the best ground to lay the foundations because most of them guarantee a working pressure enough for traditional building ($\geq 3\text{kp/cm}^2$) (0.03 N/mm^2).

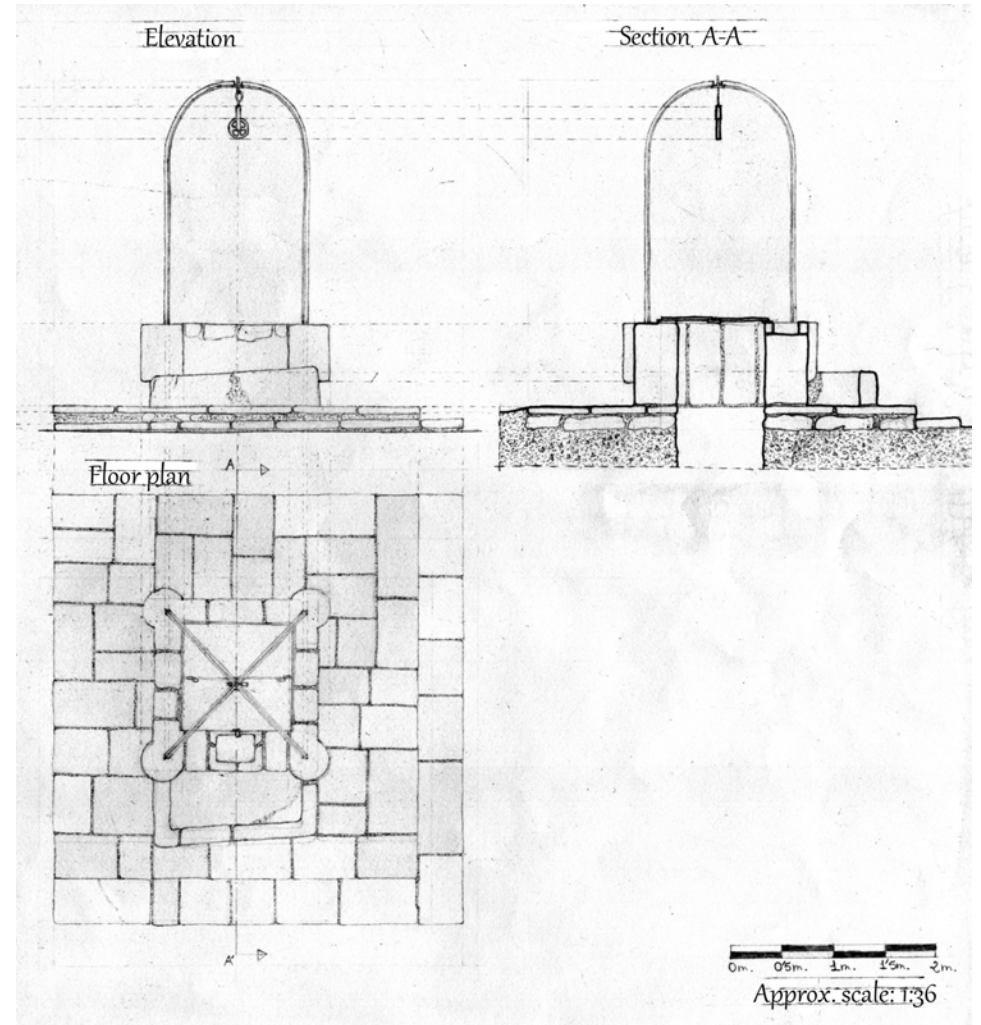
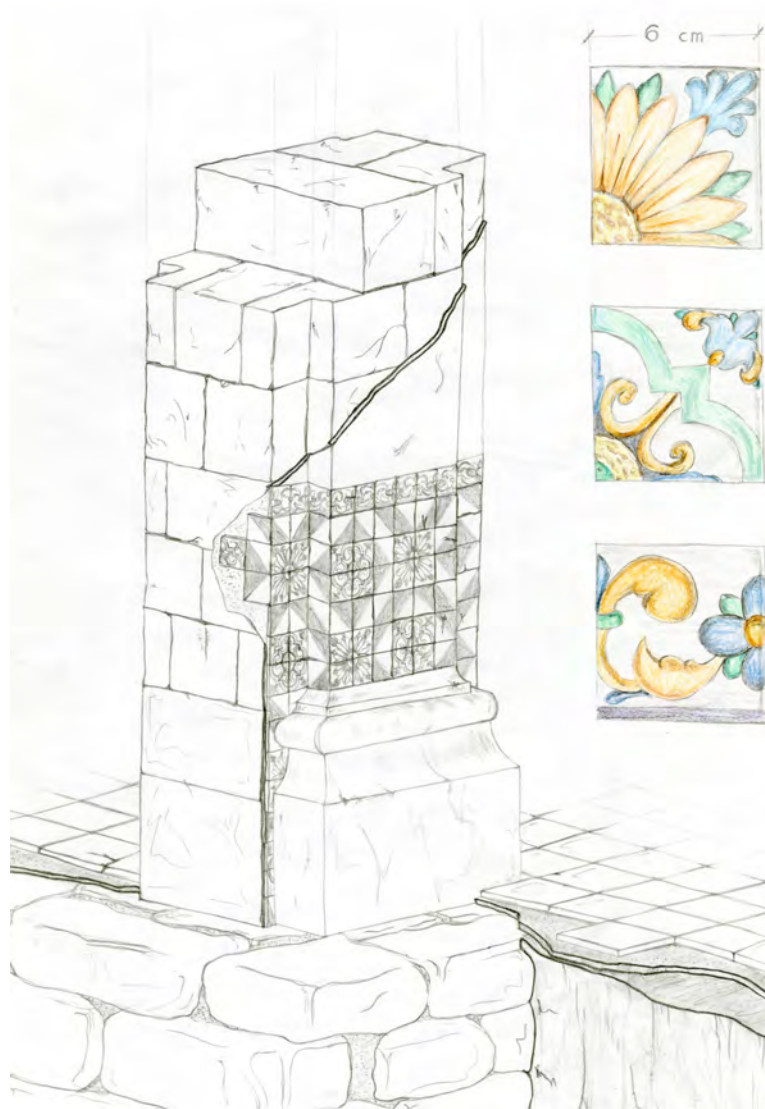

Walls

Stresses

In traditional buildings the walls are constructive elements that are responsible, among others, to support the weight of the structure and transmit it to the foundation.

Walls can be made of various materials, stone, brick, adobe or compressed earth as resistant elements joint or not by binders such as lime mortar, gypsum plaster or clay mixed with sand. The kind of the elected material depends on multiple factors: closeness, strength, durability, ease of implementation, knowledge, etc.

In the 19th century some analyses were made to estimate the influence of the joints on the stonework resistance. Engineers used a simple rule: the stonework resistance is about 1/10 in relation to the compressive breaking strength of the stone of which it was made up; due to the mortar joints and the heterogeneity of the brickwork. In that sense, if the stonework is correctly assembled, the resulting compressive strength will be higher in the centre or vertical axis of the wall.

The resistance of brick walls and rammed earth walls depends on their constitution, granularity, dosage and execution, being much more resistant the first ones.

The traction resistance of the stonework depends on the adhesion between mortar and stone or brick – almost zero –, and the sliding failure is prevented

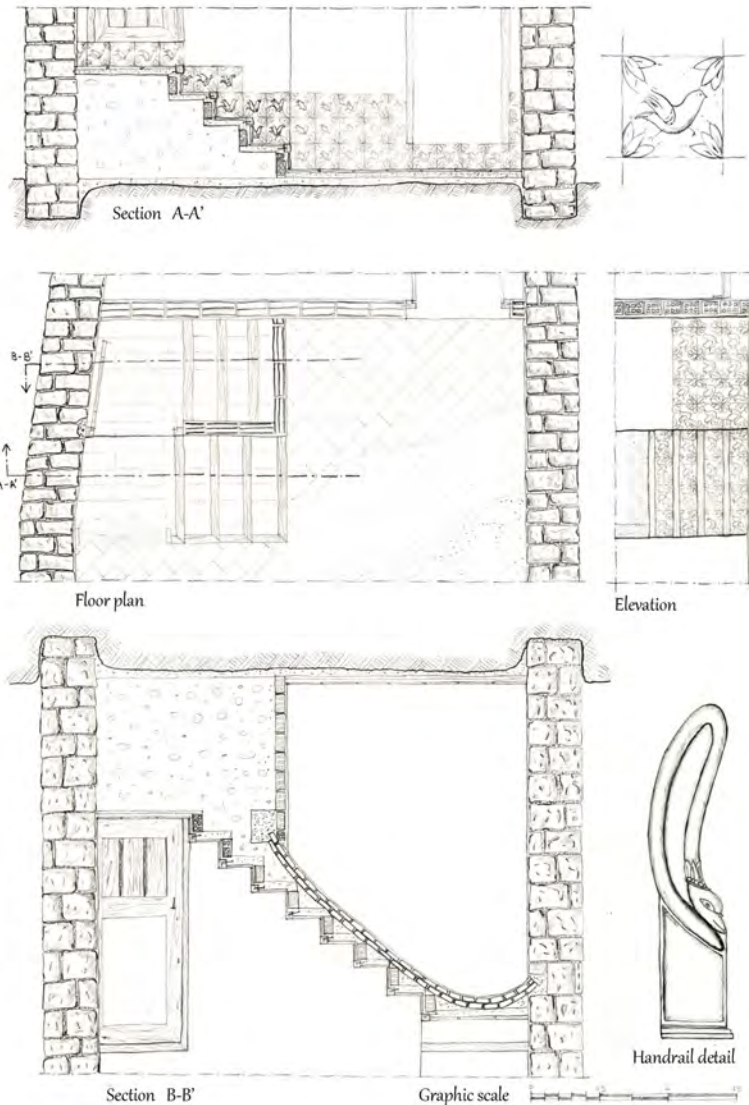

by the high coefficient of friction between the stones and by the habitual way of assembling them.

Professor Heyman systematized these affirmations to set up the Principles of Extreme Analysis of Stonework:

- Stonework has an infinite compression resistance.
- Stonework has no traction resistance.
- Sliding failure is impossible.

Stonework

The ashlar stone is a stone carved in the form of rectangular parallelepiped, which is part of a masonry building. In these building compositions, ashlar blocks are placed together forming what is considered almost sculptural elements, in which work is valued primarily by the carving, the brickwork and the quality of the stone used.

The masonry walls can be carried out without mortar, although most employ a slight grout slurry to facilitate the entry of the blocks.

The wall of masonry exterior walls can present different types of stone, according to the quarry, and different types of brickwork, depending on the time of construction and building quality. The internal part could be executed by a completely solid section and variable thickness.

The interior could also be left completely hollow or filled on the base of rubble and lime mortar, both types significantly reduce weight and save material compared to the first solution.

In many cases, the stonework may be composed of an external sheet of regular masonry and an internal one with irregular masonry. Both have similar mechanical properties but the irregular masonry is more economic regarding the execution of the wall.

The regular masonry walls must be constructively solved with respect to vertical and horizontal stresses. Against the vertical stresses – compression –, the sheets which compose the wall should be well constructed, discontinuously. This means that sheets will be of variable thickness, intertwining between them, and never following a perfect vertical line in the vertical axis. Facing horizontal stresses – tensile or earthquake – the pieces should be joined by clamps or clips or anchored to timber or metal elements of floors and roofs or even to other buildings.

DETAIL OF MAIN FAÇADE

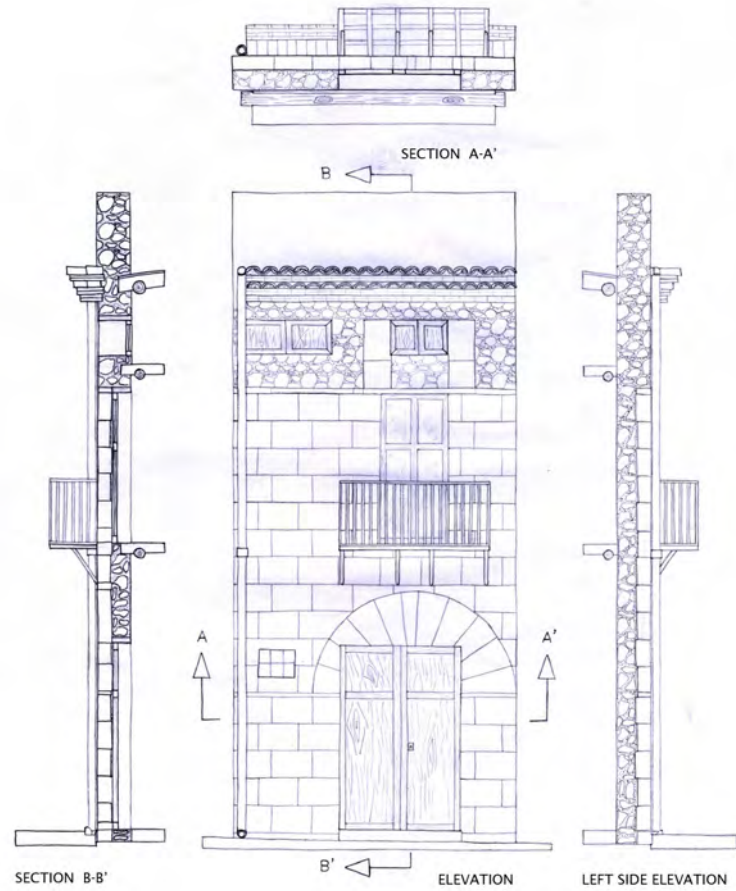

Approximate scale 1:40

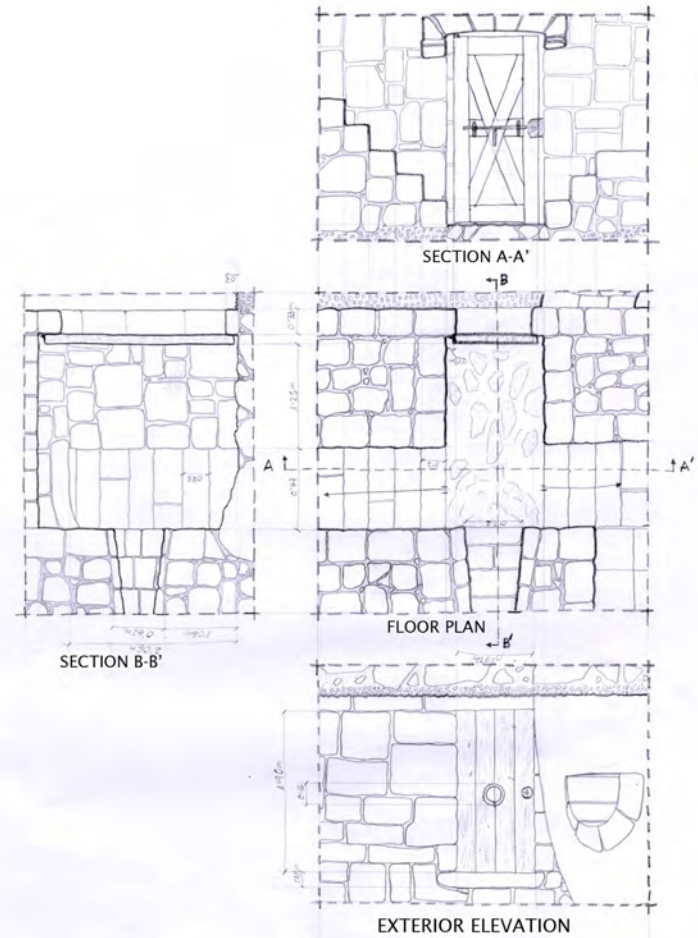

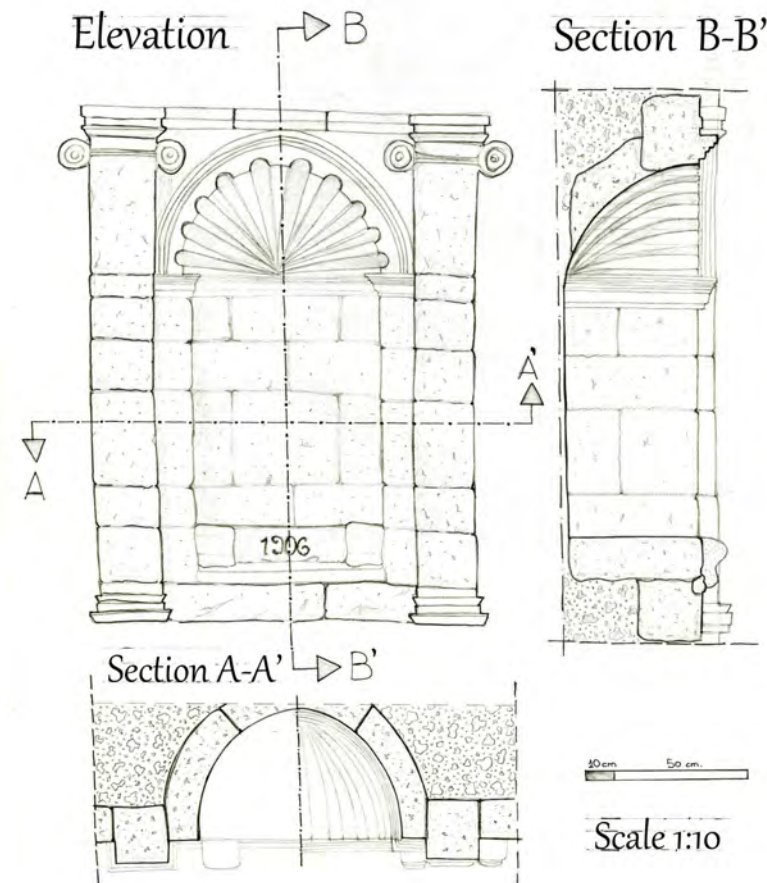

Masonry

Masonry is a stonework made with irregular stones placed and fitted between each other, taken with plaster or simply dried and arranged in certain row or size order.

It is the dominant wall type, in which, according to the quality of the stone and the relevance of the building, the irregular stones will receive preparation to a greater or lesser extent.

The irregular stones can have a great variety of forms, depending not only on its preparation but also on its origin. Irregular ones which derive from the act of removing stones from rocky fields will usually be amorphous, others are rounded off by the torrent effect and others are pseudo prismatic if they have been quarried. Therefore, there are various types of masonry – ordinary, faced and concerted – from the most imprecise to the higher smooth down work of irregular stones.

All of them create masonries which need to be either settled by small pebbles or the ones which require a large amount of mortar in order to constitute a pseudo-horizontal course in charge of transmitting uniformly the vertical loads.

When that kind of walls are carried out in housing buildings, it is normally done to exercise a sustaining wall function, being the usual width of 18 inches (equivalent to the ancient measure of two Valencian palm lengths). In monumental buildings (churches, castles, etc.), the width of the walls tends to be considerably greater.

Mortar joints are usually composed of lime mortar, although gypsum plaster is also used or simply clayey mud to which gypsum could be added, or not, in order to accelerate its hardening.

It is also possible to find dry stoneworks (without mortar joints), normally used in small buildings, which forces the construction to the finest execution in order to assemble each stone among the others achieving a correct load transmission.

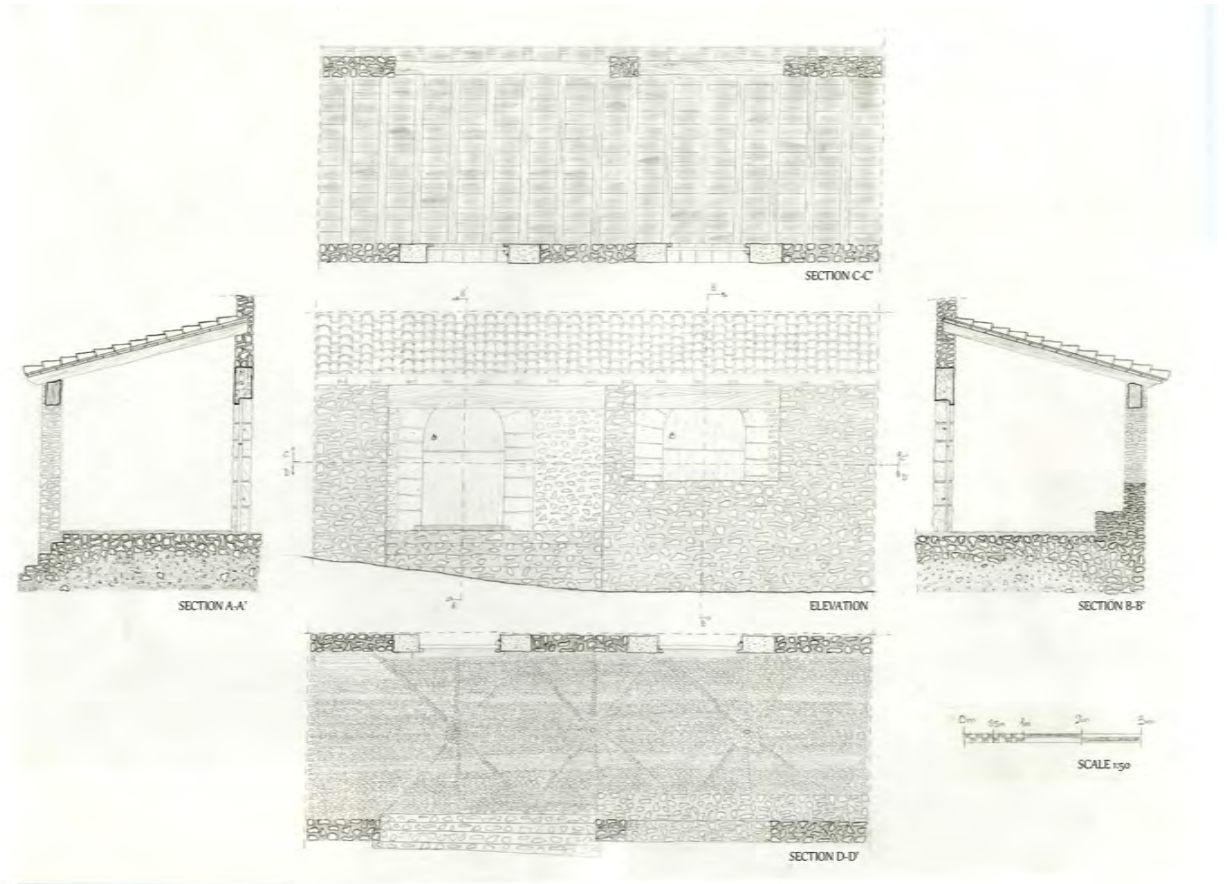

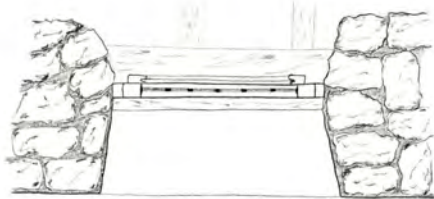

PLAN VIEW



ELEVATION

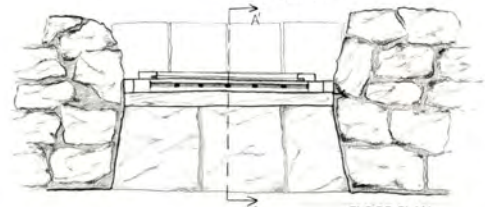

FLOOR PLAN

A06, SIDE ENTRANCE

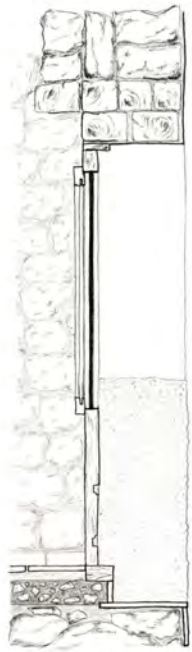

SECTION A-A'

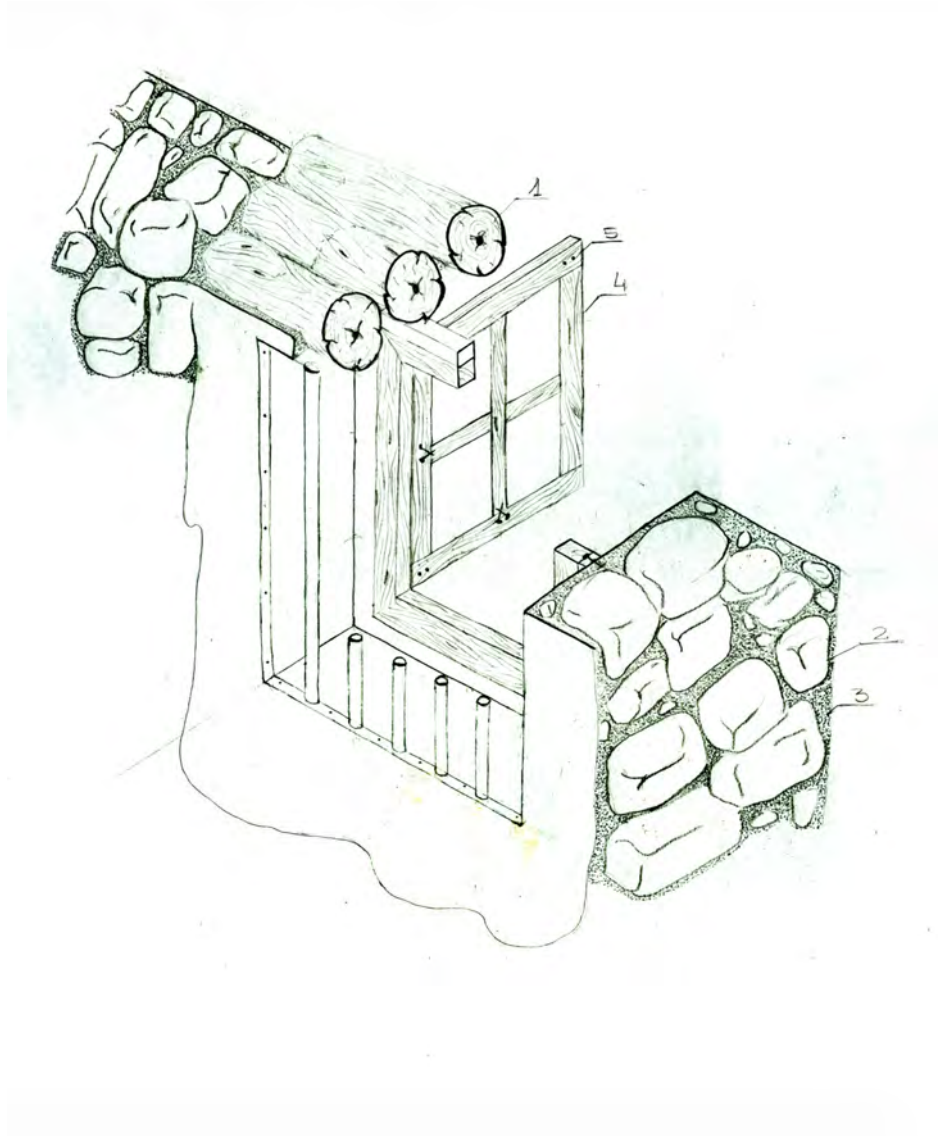

Ashlar Masonry

This stonework is a kind of building technique reserved to singular buildings, although occasionally it can appear in minor construction. Sometimes stonework is used with other materials (bricks, irregular stones), with the purpose of strengthening the most weak points of the walls, –as in corners, doorposts and lintels of the openings, in the baseboards, etc.

In masonry walls, a key factor of wall stability is the size of its cornerstones and its correct assembling with the rest of the irregular masonry. It is usual to place ashlar with some kind of rough stone to join two perpendicular walls for bearing possible horizontal thrusts. Stones normally come from the surroundings of the building, and therefore it is possible to perceive a clearly distinct aspect in the different regions where stoneworks are found.

In some cases there can appear blunt or bevel corners, both either in the whole height of the building or just on the first meters from the base of the load-bearing wall. They have no other function than to facilitate the means of transport getting through in rather narrow streets.

In traditional construction we often find reused elements from other previous buildings due to the pillaging of some elements or parts owing to their abandonment or destruction.

In mixed load-bearing walls construction (owing to the advantages contributed by some materials or the deficiencies observed in others), it is also usual to find the combination of ashlar and brick, rammed earth and adobe. However, depending on its quality, compressed mass earth walls might turn out to be unoriginal in some cases or revoked and whitewashed in others in order to protect the minor quality materials and the rather erosive ones of the elements.

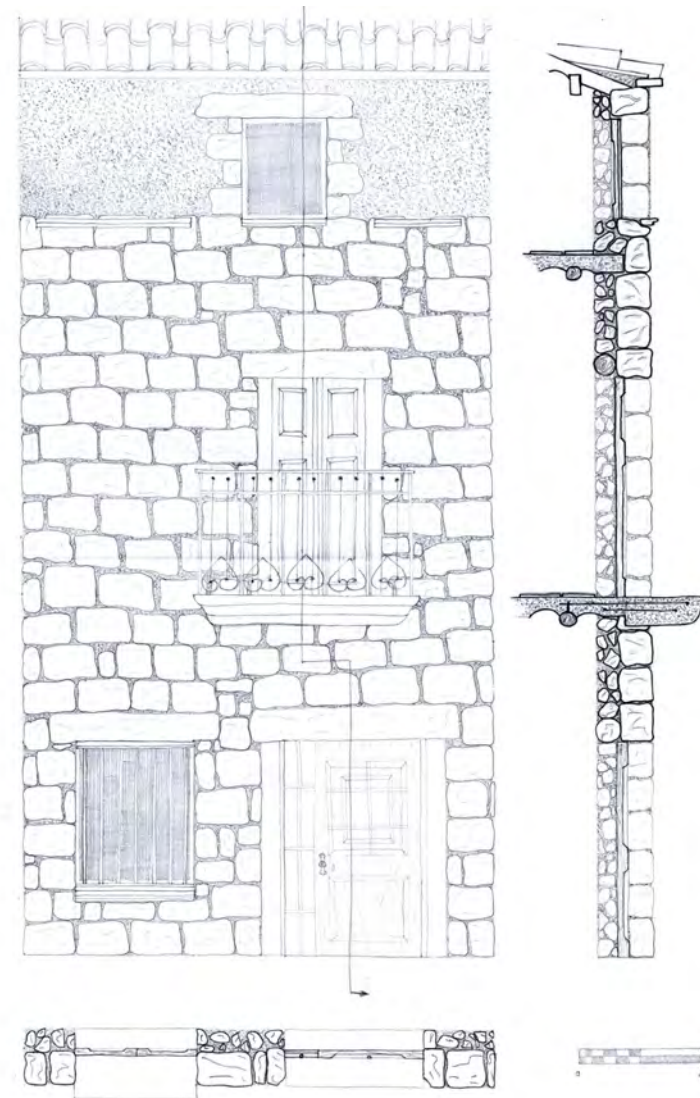

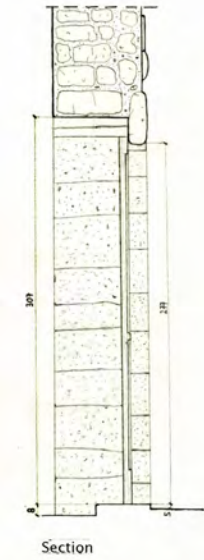
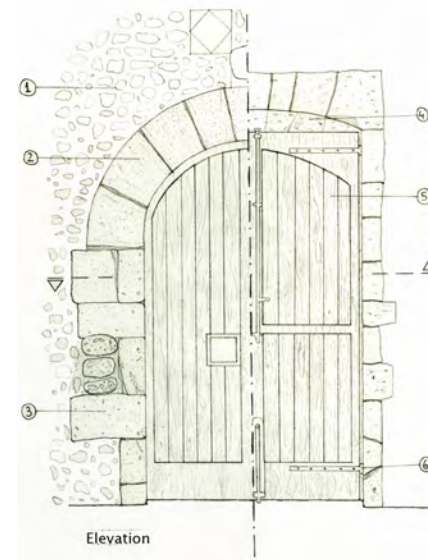
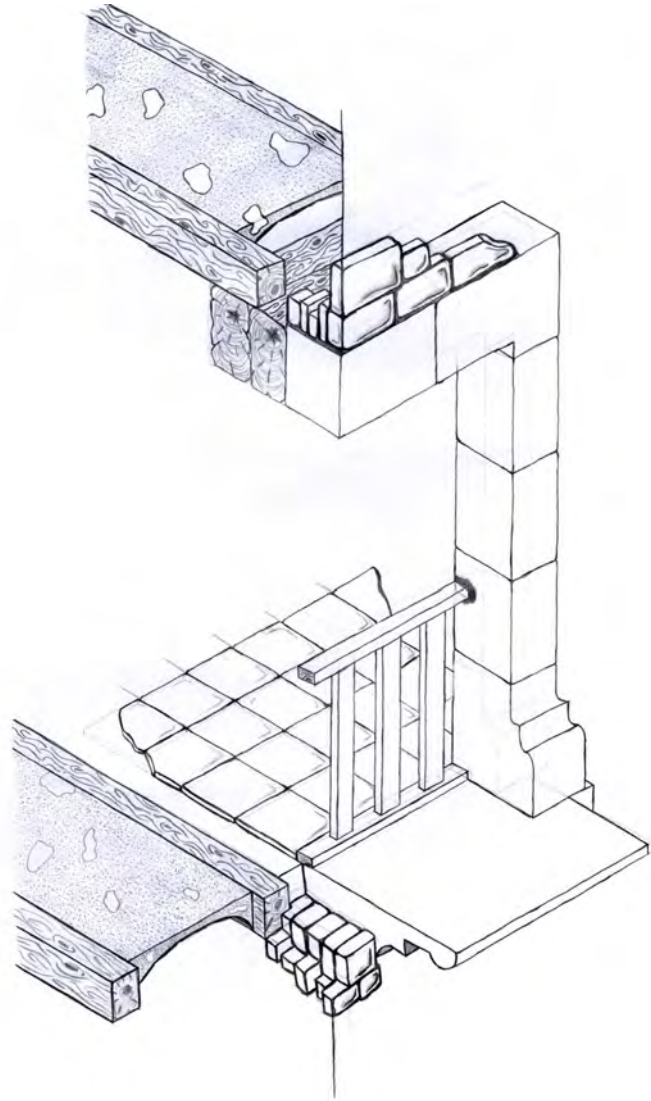

Elevation

Section

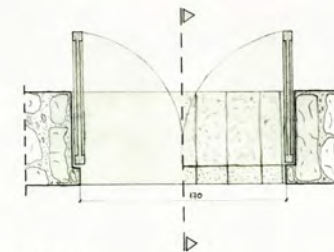

Plan view

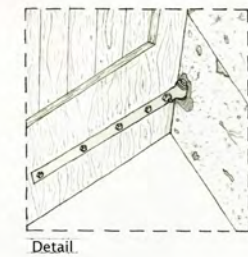

Detail

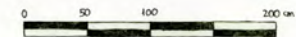

Sun-dried bricks and industrialized bricks

Adobe is a prism-shaped piece made of clay, usually mixed with straw, molded and left to dry uncovered, which is used in wall's building whose size allows being handled by a mason with only one hand.

Adobes or brick placing correspond to the same family of construction techniques; the so-called addition by which the parts lose their individuality by tangling up with others with the same features in order to form a homogeneous element. The union between adobes is realized with mud, while bricks are normally placed with mortar, occasionally made of lime and recently made of cement.

The low resistance found in sun-dried bricks do not allow its disposition to make up small section pillars since they are unable to bear concentrated loads.

Due to the adobe's reduced resistance towards moisture it is advisable to cover it with mud or lime mortar. Bricks, however, can be used without protection, even in horizontal surfaces as cornices and friezes, forming beautiful tackles. Nevertheless, it is rather usual to protect tackles using a continuous covering with a subsequent painting.

Traditionally, bearing walls have been constructed with both materials, usually with widths of at least 25-30 cm. With these materials, because of their modulate shape, bearing walls can be lifted with a consumption of about half the material used in masonry walls.

It is common to find bricks strengthening the weakest elements of irregular masonry walls, as well as it is explained in the case of regular masonry. In addition, it can be placed in courses regularizing large masonry walls.

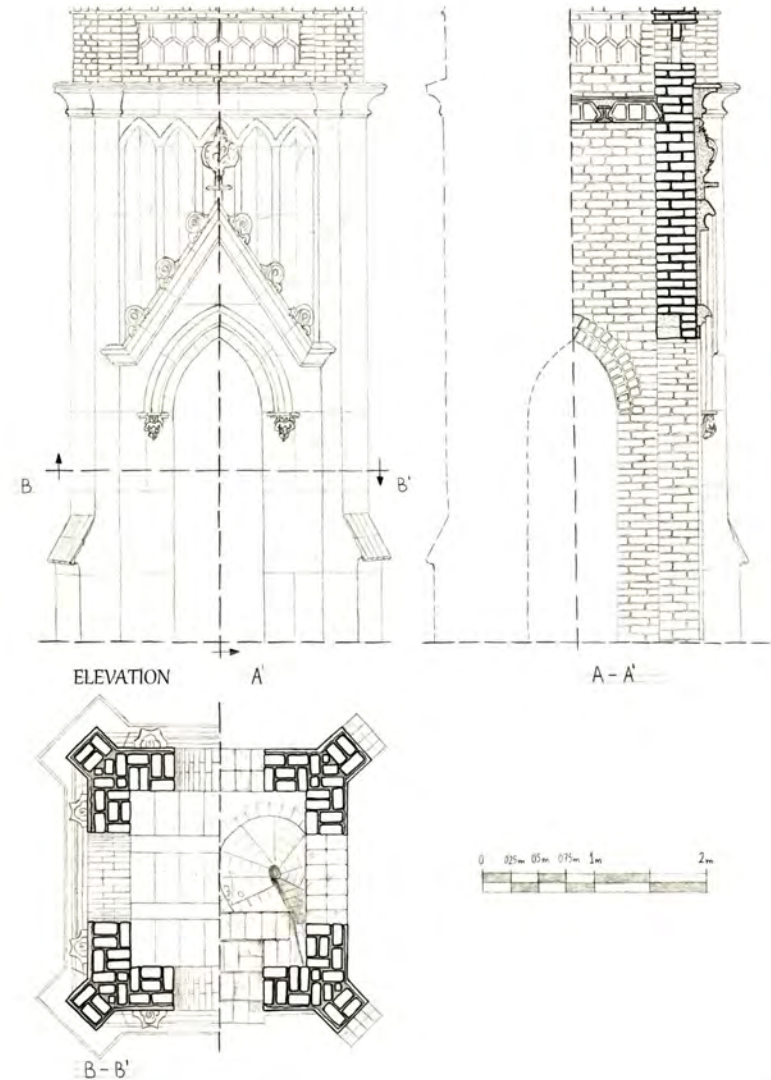



TOP VIEW



ELEVATION

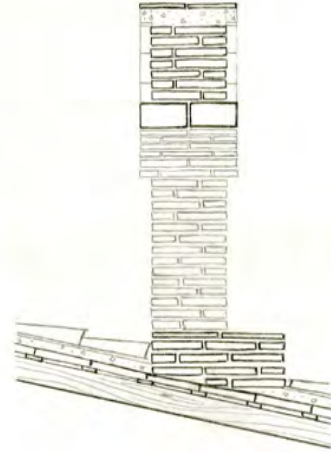

SECTION

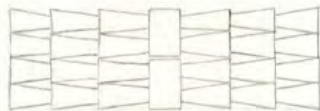

FLOOR PLAN

SCALE

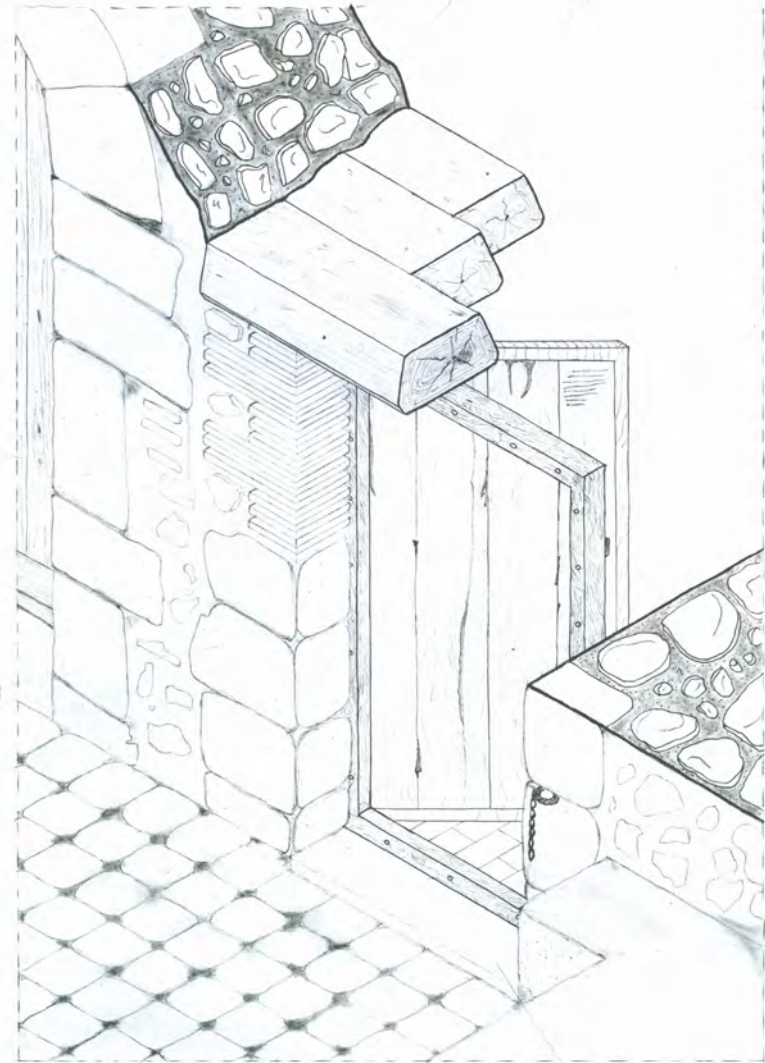

Rammed earth

It is said that a wall is built with the technique of rammed earth when it has been done with the aid of a frame (formwork). Usually, rammed earth is the kind of traditional construction in which wet earth is poured and rolled on the inside of a mould, and sometimes straw is added.

The width of the wall thickness of compressed earth walls, never less than 45 cm, compensates their relative resistance to compression, being able to use them, therefore, as bearing walls, reaching in some homes up to four stories. In fact, the compressed mass is porous that it confers a good acoustic and thermal behaviour to the wall.

The proper grounding should consist of clay, silt, sand and, in general, also gravel, usually being used the one coming from the surroundings, although it might not meet the most suitable conditions.

There are different types of rammed-earth walls depending on the main material and how it is used in the construction work. The lime-crust wall which is carrying a coating of lime mortar placed at the same time while the soil is being poured and tamped, has been the most used in traditional construction. There are also ordinary walls (soil only), those made of lime or concrete gypsum and masonry, and the mixed ones which are formed by the combination of various materials (bricks, masonry, plaster, etc).

Apparently simple, this technique has been employed in all kind of buildings and its longevity, as well as for adobe, it is subordinated to the prevention

of its three weak points: the base which isolates from ground humidity, a prominent eave which protects from the rain and, not less important, the regular care of their surfaces.

Openings

Windows

An opening is the hole made in a wall specifically with the purpose of connecting spaces, ventilating, lighting up, etc... Traditionally, and until the massive use of arcaded building, the configuration of the openings was long, dominating the height over the light.

The structural solution that covers the span may be by lintel or arch, elements subjected to bending stress without deforming, or admitting a very slight deformation, transmit loads to its supports, the jambs. In many cases, execute an arc discharge can lighten the stresses acting on the lintel.

Lintel has the same functions than a beam that directly receives an uniformly shared load which transfers it to its supports, the jambs. The placement of a single piece or more, the entire thickness of the opening, is directly related to the wall thickness and dimensions of the available element.

This concentration of stresses highlights the importance of higher quality construction in the jambs than in the rest of the wall. Therefore, we seek for a higher quality execution at these points than in the rest of the wall because, as well as it happens with pillars and concentrated loads, larger caliber stones with special edging are often used in order to facilitate better contact between the stones. Thus, in many cases you get to use masonry stonework on walls.

There are several kind of lintels: lintel made with an element composed of a single piece which covers the hole opening length –timber or stone- or lintel composed by several elements or pieces – timber, stone, brick-. These are the five variations of lintels that give rise to all possible combinations.

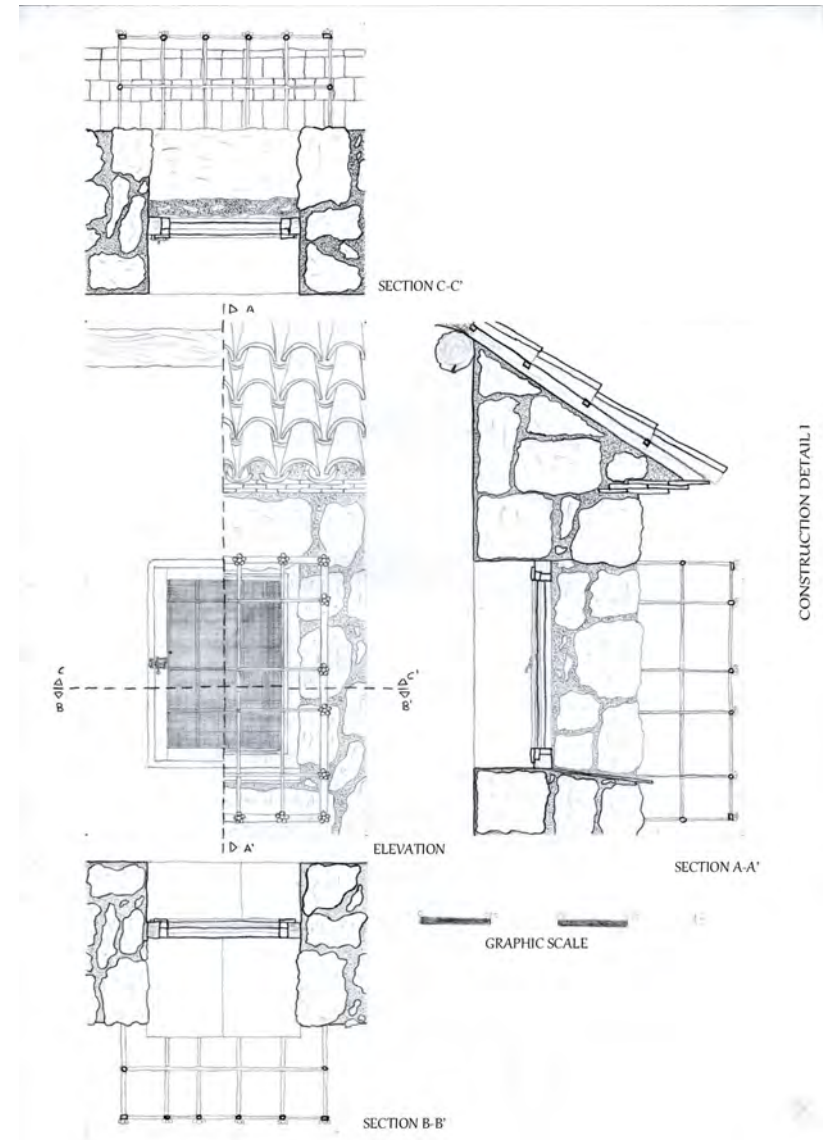

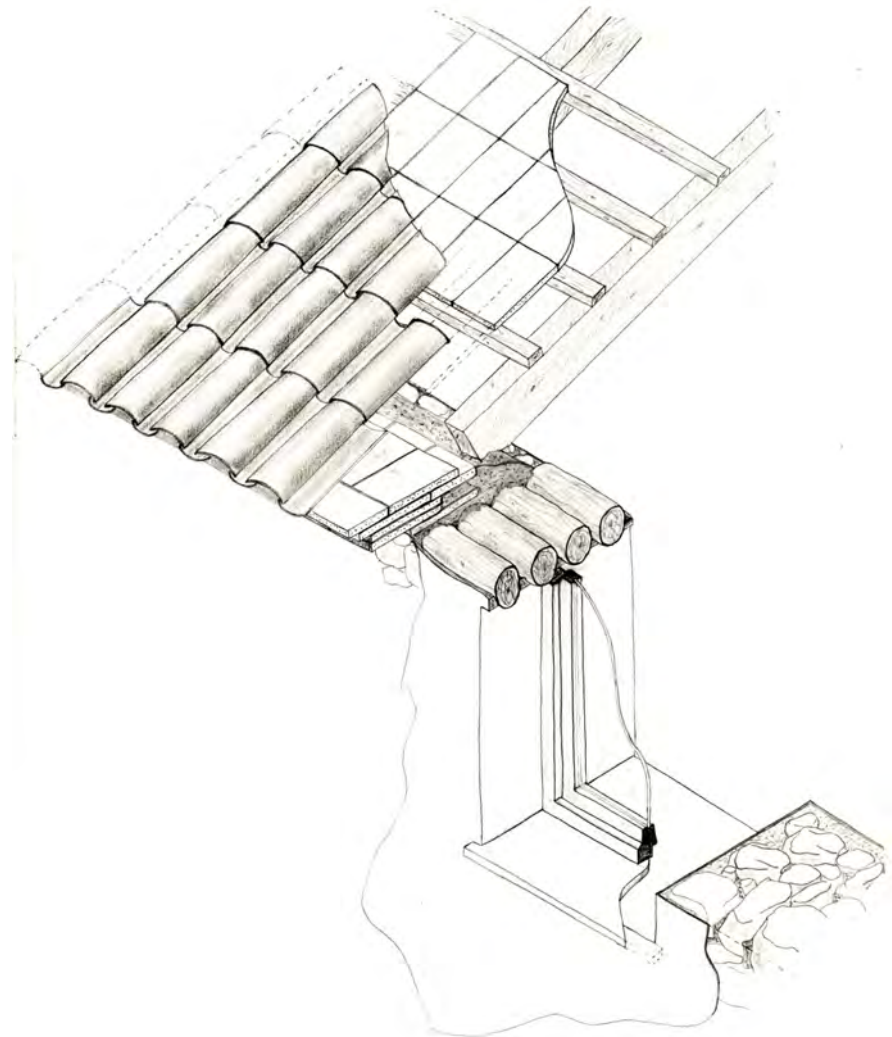
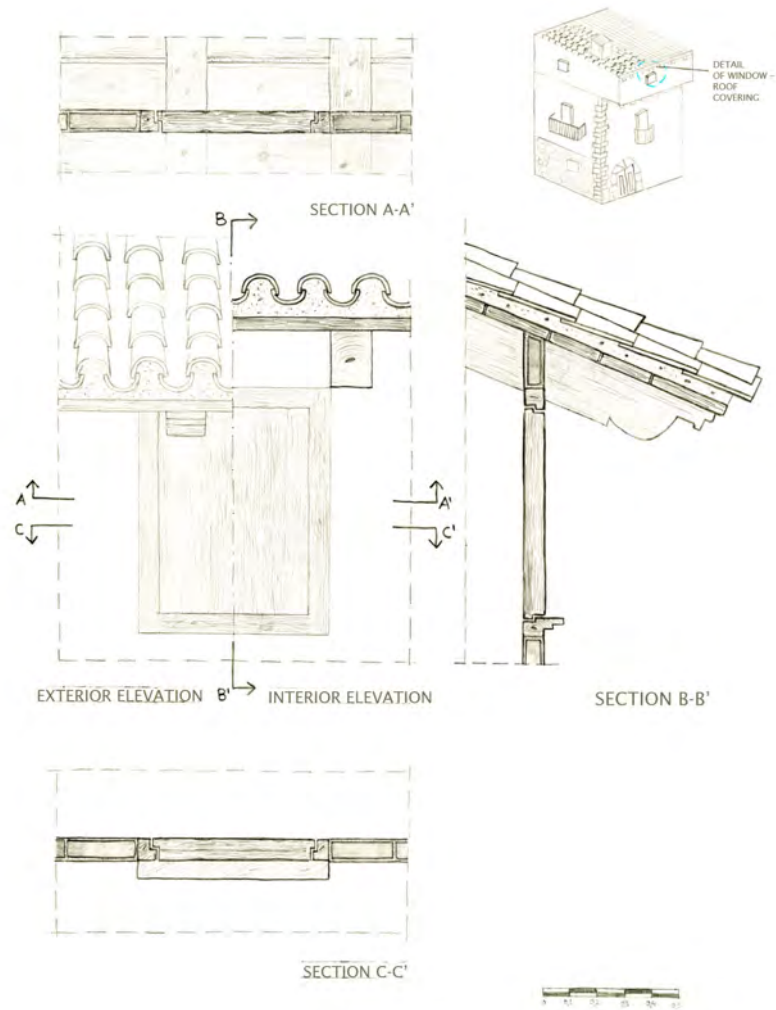

Doors

In ashlar masonry, openings are normally covered with a single piece which works submitting a bending stress by working as a lintel, or several elements or ashlar pieces can be split in order to form an arch, semicircular, lowered or horizontal (false lintel) to transmit compressive stresses to jambs.

Brick load-bearing walls usually solve the opening structure preferably either with bricks if it is an arch, or it is also possible to find ashlar stones or other prefabricated pieces. All these solutions enable large open spans. Irregular masonry constructions, more erratic in its form, cohesion and solidity than the other ones, create many limitations and, therefore, smaller openings.

This is also the case for sun-dried brick, rammed earth or dry stone. With the purpose of shaping the door in soil techniques, it is often resorted to a whole wooden door frame previously assembled to help stiffen the doorposts and lintel, mounted in order to offset the risks of material deterioration. In these three techniques, openings should be no longer than 1m. Owing to the excessive stress concentration on jambs, the door is the biggest opening.

Finally, it should be claimed that all those openings not only serve to light up the inner parts but are also an observation place, a social viewpoint, the last private area from which the public space can be observed.

The opening, apart from being utilized as a facing perforation where to host a carpentry element to be favorable for communication, inner ventilation or lightening, can be understood basically as a large size structural element, in the shape of an arch or a lintel, which replace significant facing portions. Normally, these openings have specific names: hallway, gate, arcade, porch, loggia, etc.

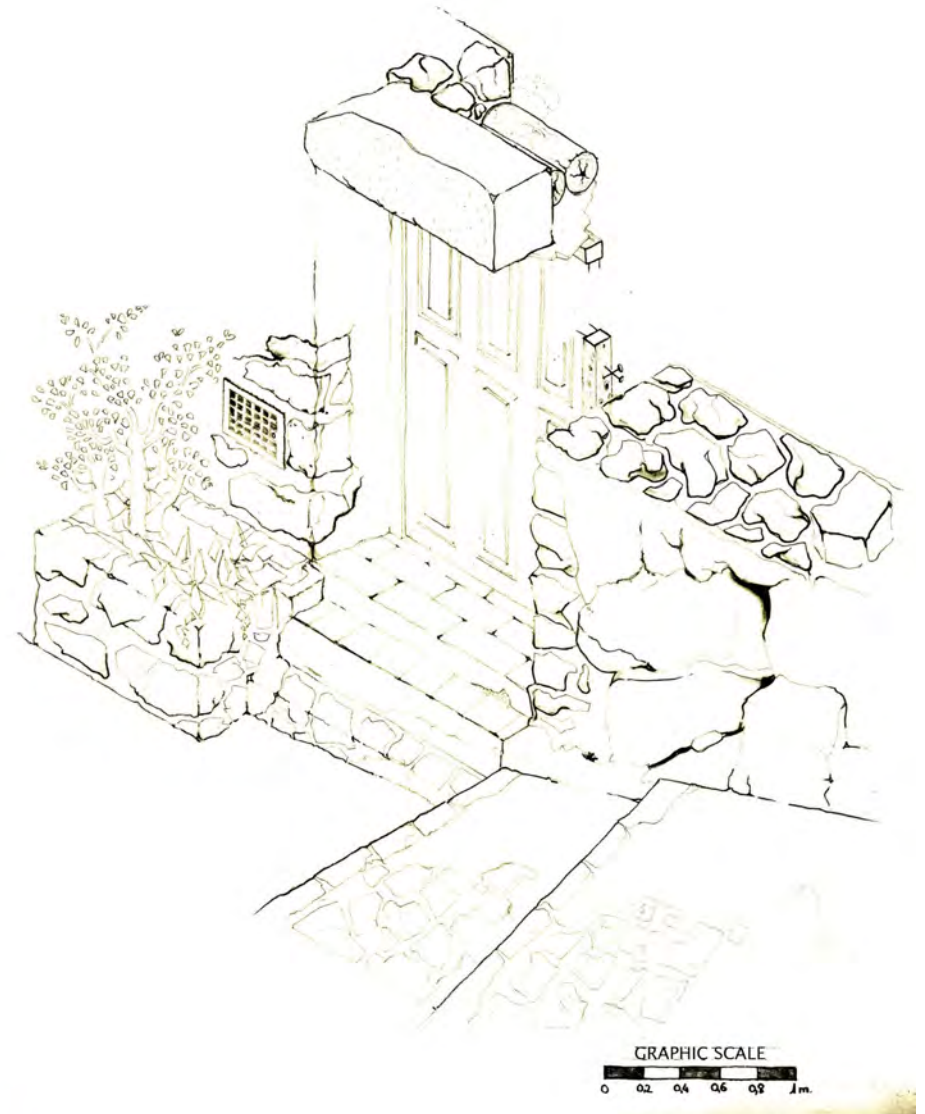

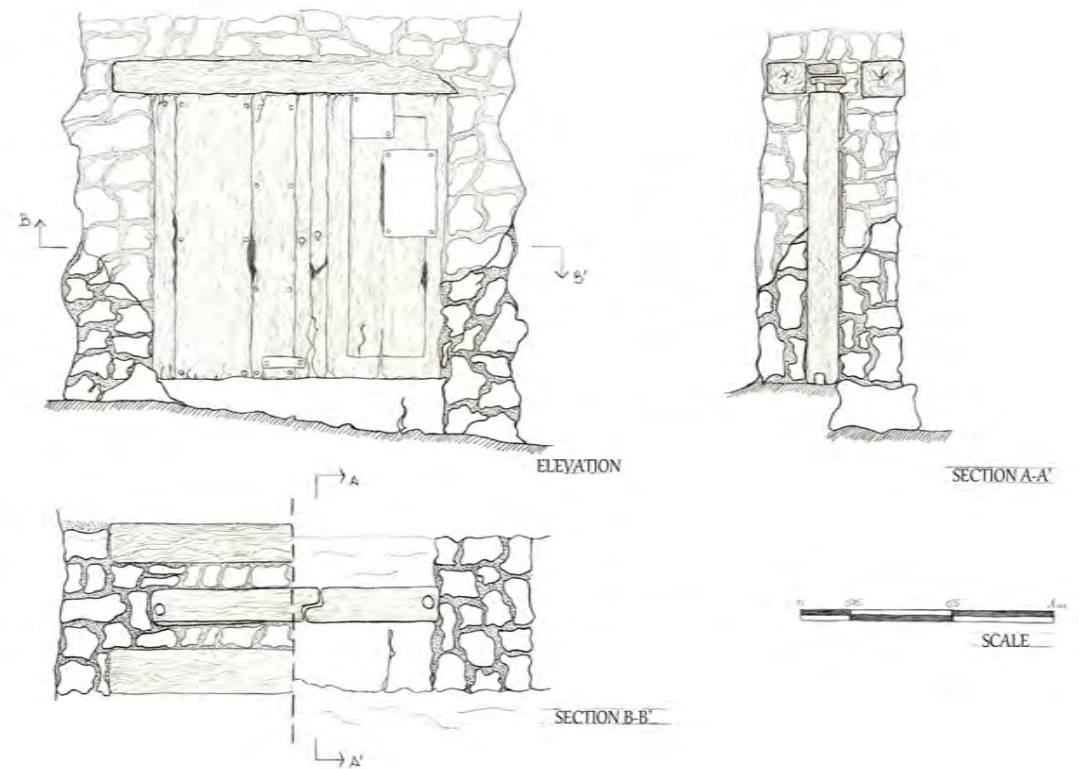
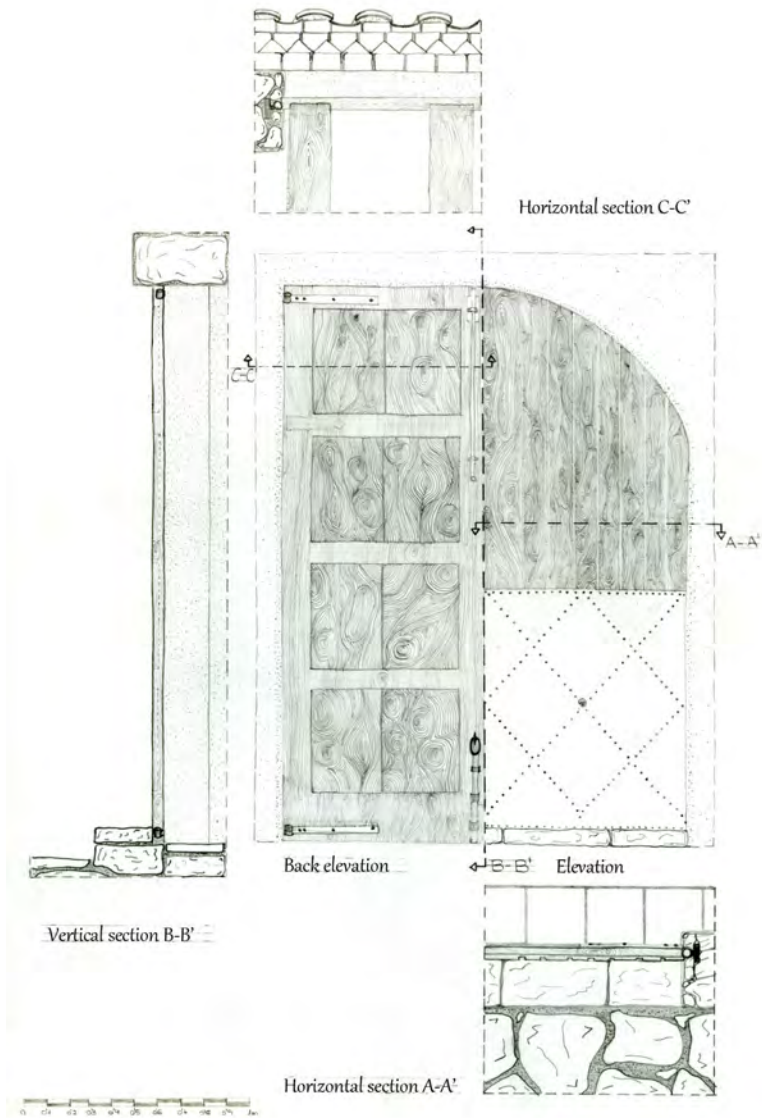

Balconies

A balcony is a developed element from the small quadrangular window. In its primitive and traditional form, a balcony was a section or railing in which a profile or balustrade was leveled to the external wall face and remained fixed in it with mortar and, in many cases, nails to improve the holding. Its evolution, as a wooden balcony, is presented as a projecting structure, a wooden stage leaned in small beams perpendicular to the facade and embedded in it. Always provided with a balustrade and sometimes covered by the prolongation of the roof or by its own small roof, whose small beams are resting on a crossbeam and embedded in the facing. A different type of the in-built small roof crossbeam is the angular brace, whose beam works in the shape of cantilever.

Timber was replaced by stone in all bearing elements of the balcony when material abundance made it possible. Subsequent balcony evolution took place due to a metal structures that unified the balcony base with its balustrade, granting more lightness and inertia against falling over. Both the base and the upper handrail were anchored to the wall with its ends in key shape to improve the holding.

Over the balcony base structure ceramic or stone floor tiles were laid over which mortar was poured offering a certain monolithic sense to the set and also serving as balcony pavement.

Other subsequent solutions replaced the base of the metal structure by a concrete slab, poured on site or prefabricated, embedded at least one third of the wall, under the jambs of the opening accessing the balcony.

Further solutions based replace metal by a slab of concrete, poured in situ or precast, recessed, at least one third of the wall, under the jambs gap onto the balcony.

There is another opening typology that is still present but less common. These are the sunny places or row of balconies and galleries.

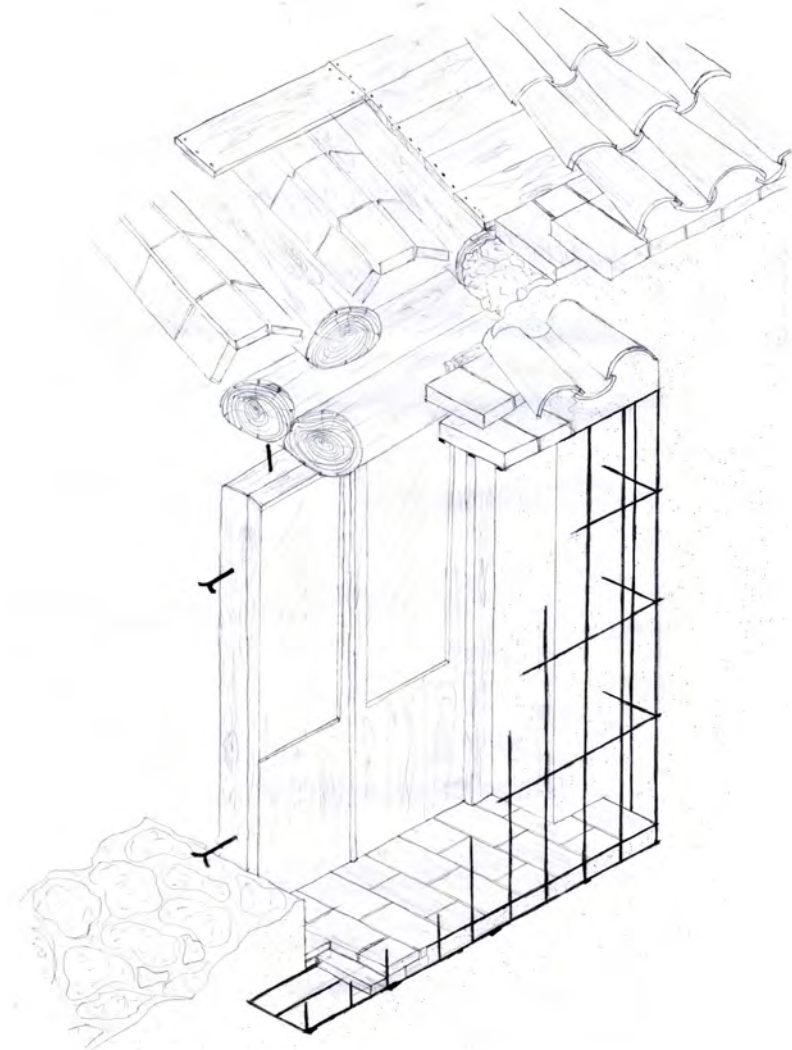

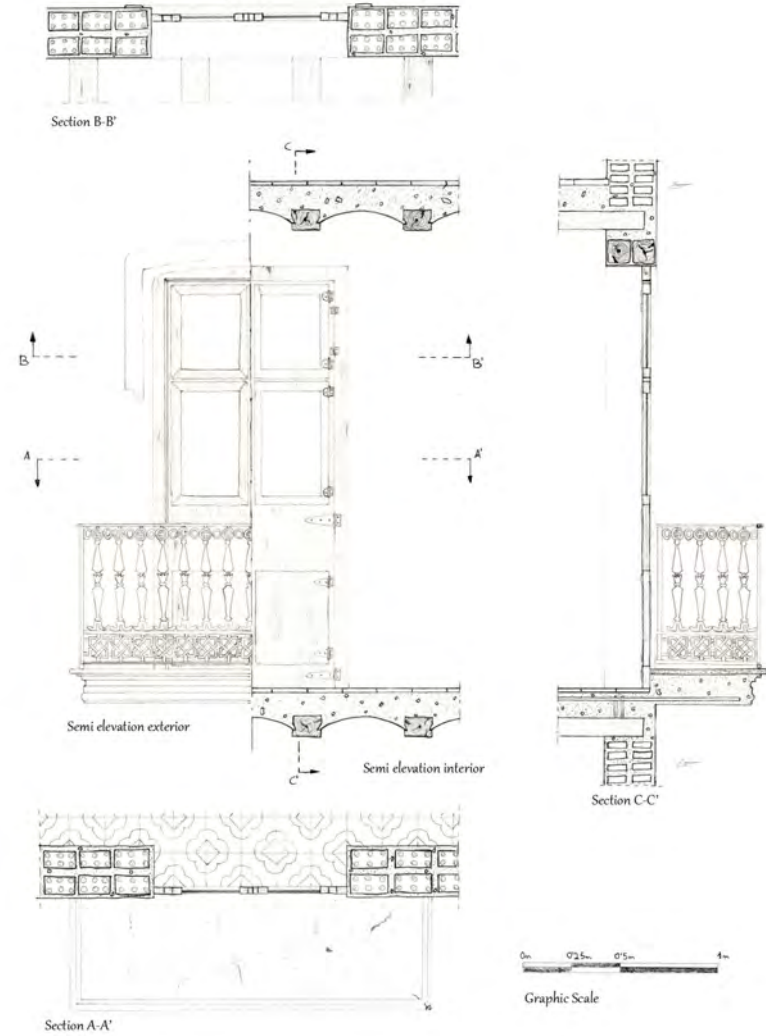
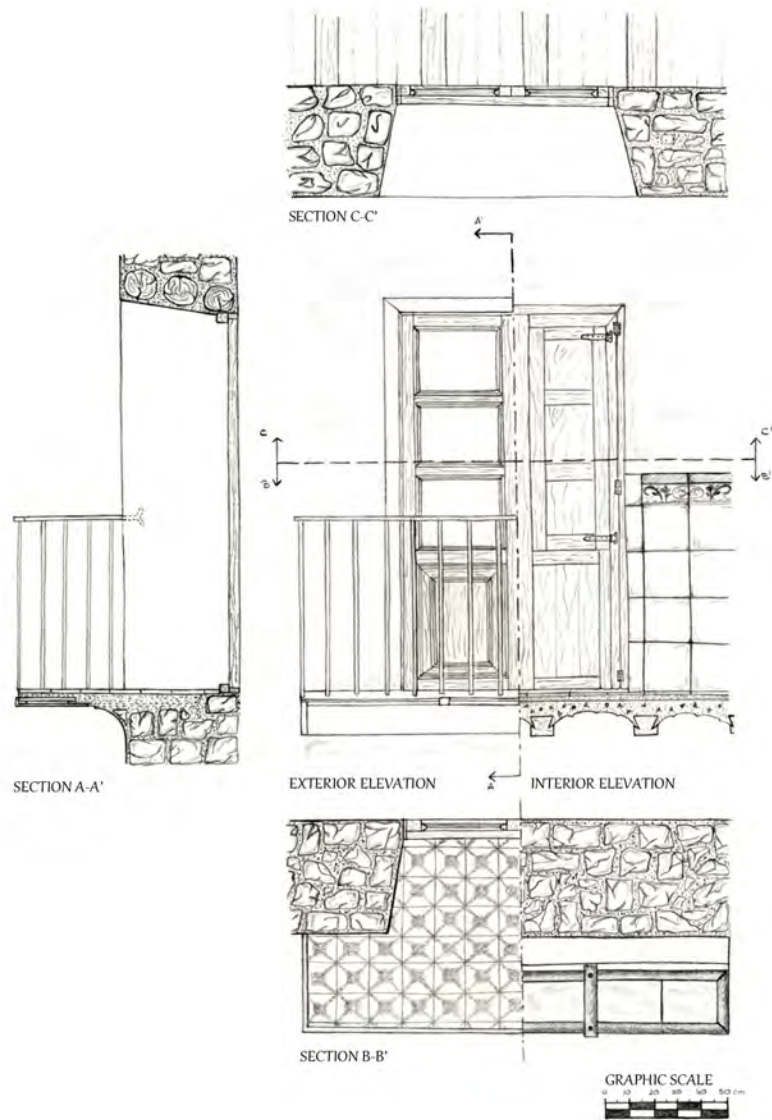

Stonework arches & vaults

Arches

The idea to assimilate arches working as inverted cables is on the origin of arches theory. Robert Hooke would say: «As flexible wire hang, like that but inverted, stiff arch will be hold up», as a hanging chain or overhead power cable.

To execute an stonework arch, the stone «segments» are mounted on a support mould, and after settling the last stone – the keystone –, the mould is removed. Stones tend to fall down driven on by its own weight – by the law of gravity –; however, the arch maintains and every ashlar segment remains in balance with its thrusts – the result of the compressive stress – produced by adjacent segments. These thrusts are transmitted to the supports of the arch, its trajectory is called thrust line. The thrust line is the geometric place in which the resultant passes across given cutting planes, and can be found in every kind of arch; geometrically line should always be contained within the edge of the arch boundaries.

In that sense, thrusts should be sloping and its horizontal component (the arch thrust) should be constant in the whole arch.

If buttresses cede when the arch is settled after removing the support mould, this will give way and crack to adapt to the movement. But several cracks or joints can take place when the thrust line gets in touch with the edge of the arch boundary. Heyman suggested, as a way to measure the safety of an arch, to compare its thickness with the corresponding limit arch, resulting in a *geometrical security coefficient* = $A.R./A.L.$

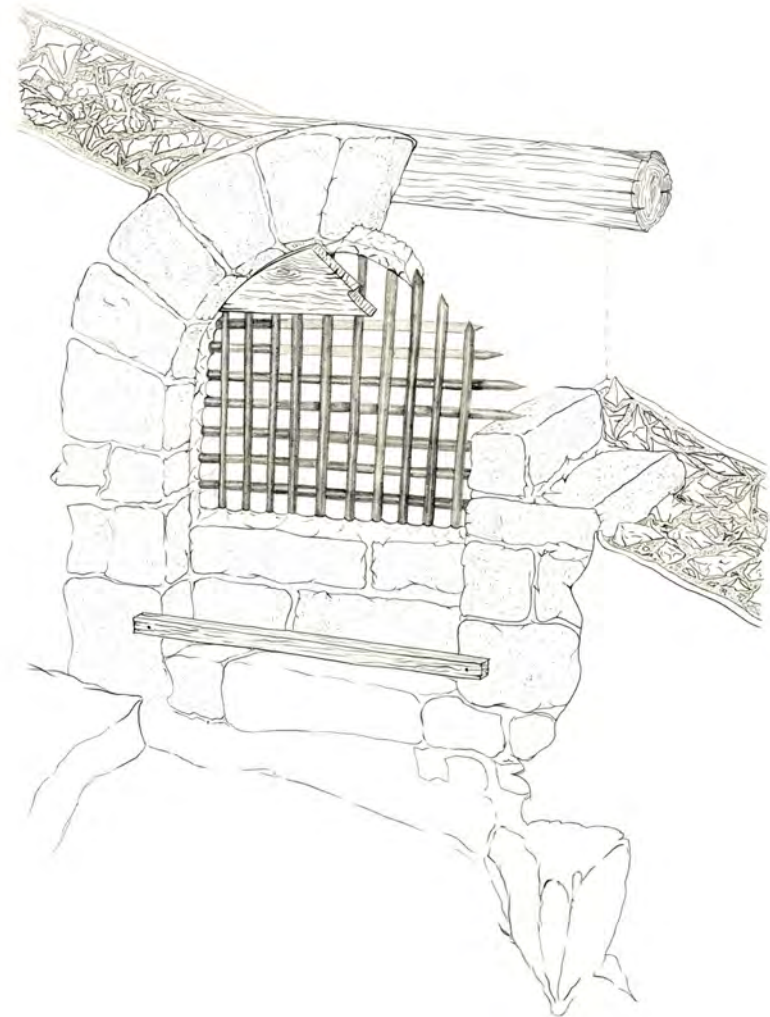

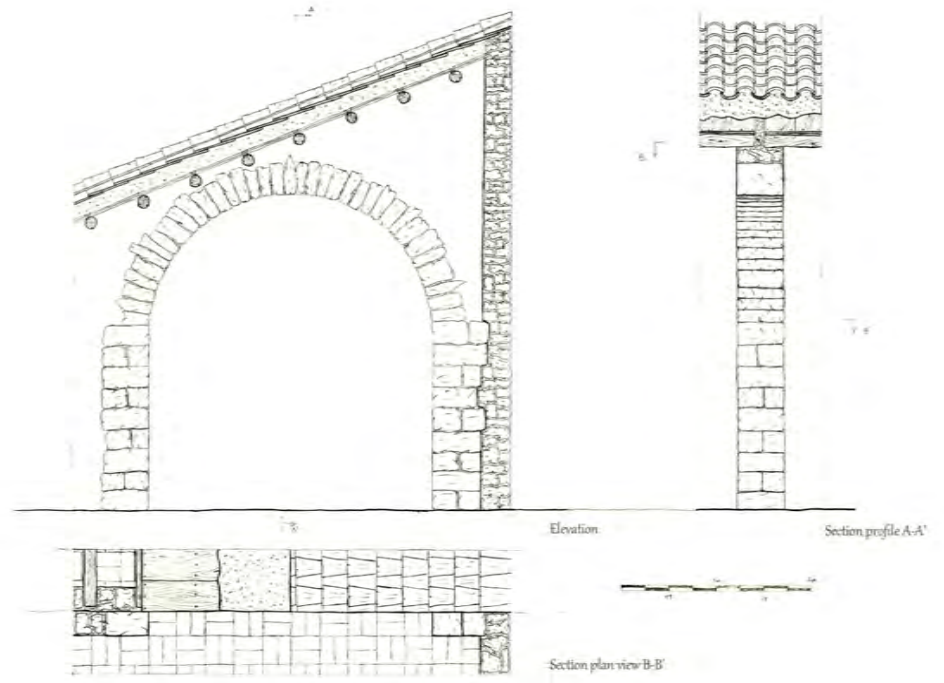
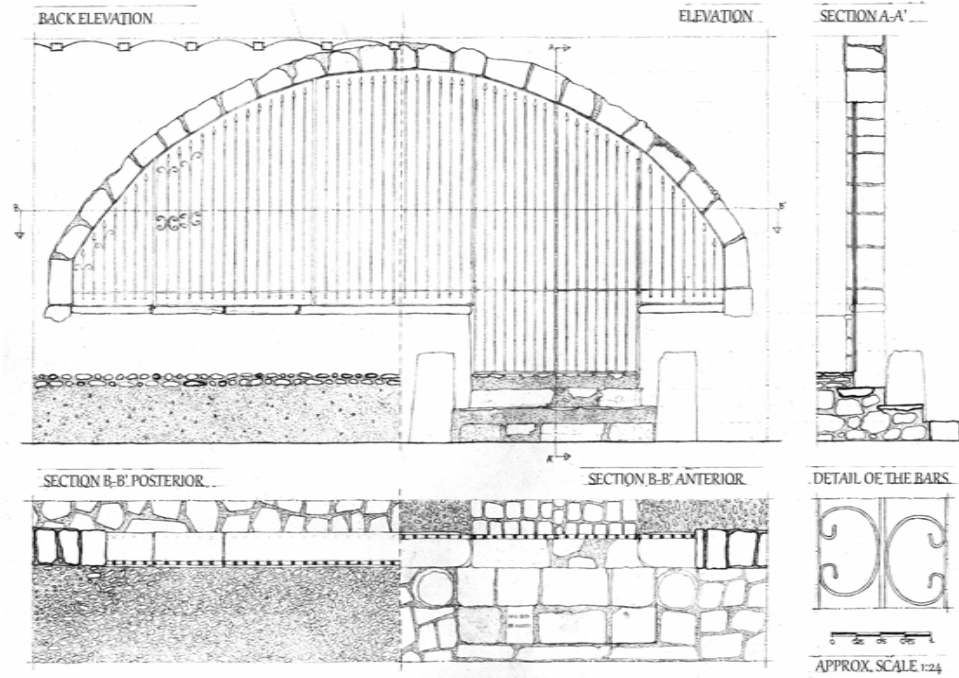

Vaults

Vaults are used to bridge the gap between two or more supports and to cover a surface. By itself, vaults can constitute the basis of an used surface, horizontal frame, roof, terrace, staircase, or also be the own building enclosure in the absence of covering material.

The stonework vaults replaced the false vault which only allowed to cover spaces of small dimensions due to the horizontal projection of cantilevered stones, limited by the tilt of the piece that stands out. The top of the vault transmits its loads to the adjacent pieces until regaining stable support in a vertical buttress where to take in the stresses. The vaults belonging to the so-called homogeneous construction as a prolongation of the load-bearing wall, very thick at kidney level, so if the whole construction loses the stresses equilibrium with which it was planned, it will tend to fall and collapse because of its heaviness. This building system is suitable to linear constructions, executed by repetition, and to cover large spans.

Generally, the most common typology is the barrel or semicircular tunnel vault, since the semi-circle transmits vertical loads more homogeneously as far as the supports: normally continuous walls with few openings. The meeting of two perpendicular barrel vaults – rib vaults – works in a different way. Each part of the vault transmits its loads in a concentrated form to pillars and not on the wall. Thus, it can be achieved by openings in the four vertical planes that encloses the sides of the vaulted space by means of the presence of four well-sized pillars at the corners.

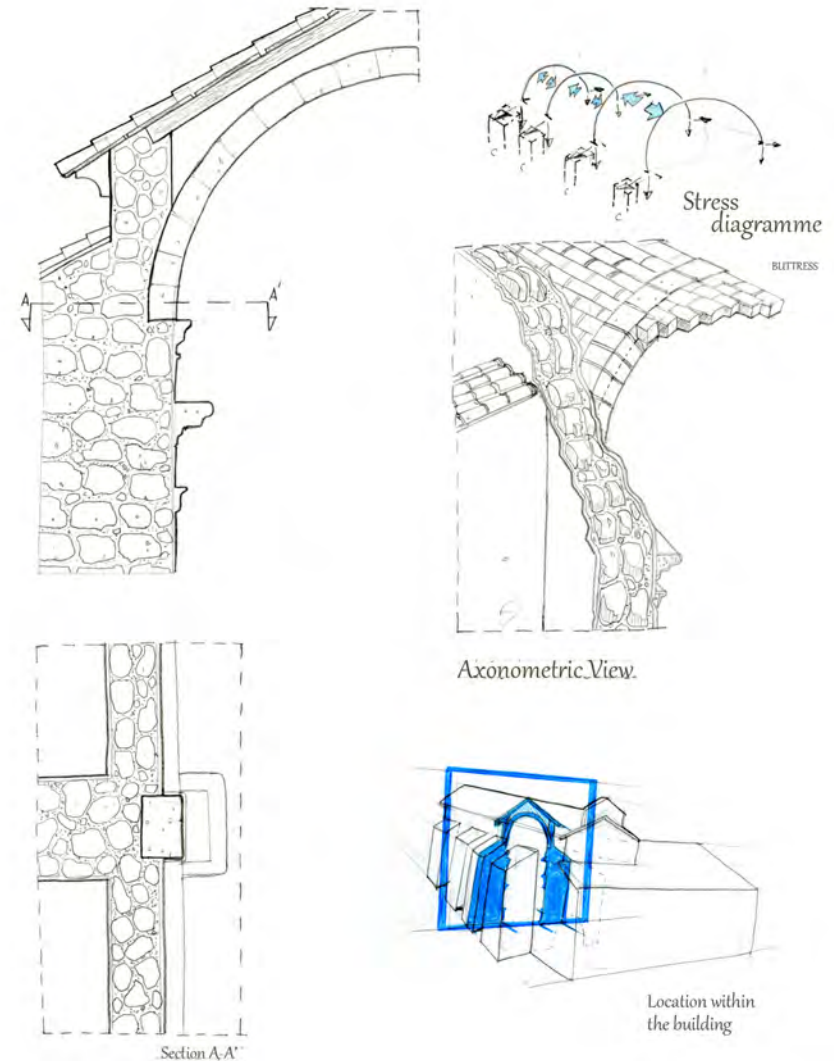

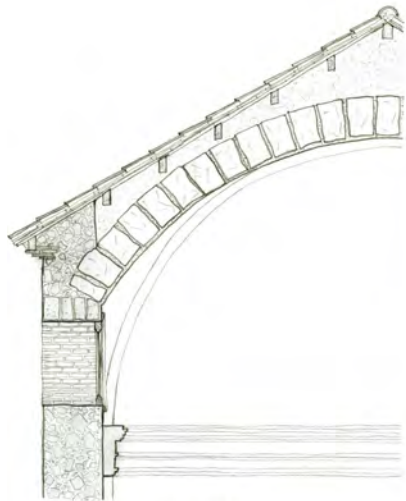

SECTION A-A'

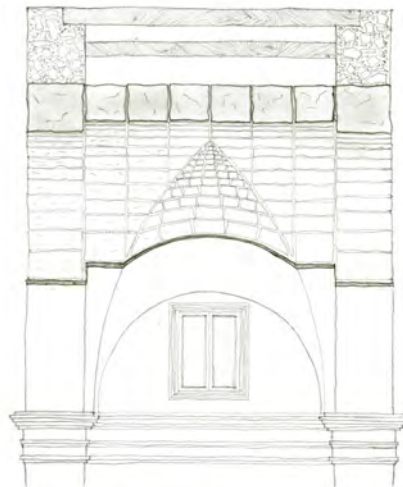

SECTION B-B'

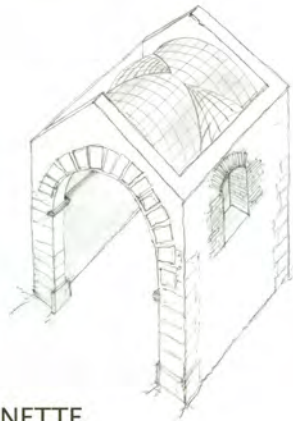

LUNETTE
DETAIL

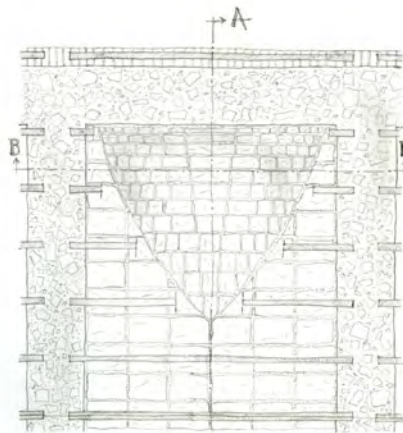

PLAN VIEW

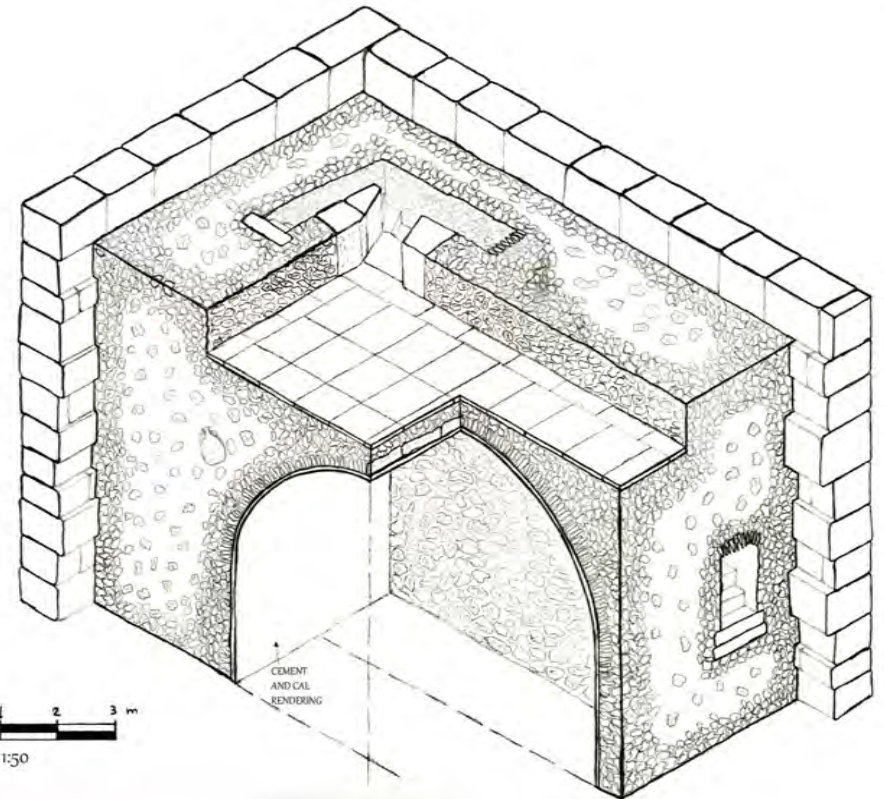

0 0.5 1 2 3 m
SCALE 1:50

Bricked-up arches & vaults

Thrusts & counteracts

The arches and vaulted structures in general, unlike the linteled, transmit loads in inclined direction in which the decomposition of the stress gives a reduced horizontal component if the generatrix is pointed or wider if the generatrix is lowered. To counter this component and ensure overall stability the walls were reinforced, first of all by using high bandwidth walls and then by buttresses.

To achieve stability of the whole, the buttress or vertical structure which supports the vault or dome should resist the loads received, in spite of being considered a secondary problem. To avoid sliding failure in the encounter between the vaulted structure and its buttress, the usual proceeding has been to load the buttress in its upper side to improve its stability and provide greater verticality to the thrusts. In conclusion, vault kidneys are filled approximately to the first third of its total height. By doing so it is possible to achieve bringing down the span, reducing it and therefore make it more stable. Thus, limit slender and real thickness can be reduced.

But obviously, sandy fillings can produce certain active thrusts, whose direction depends on the friction angle and the surface lean, among other factors.

Then, it is possible to build very thin bricked-up shells (1/100 from curvature radius) whenever they are reduced or, from the place where tractions appear, there is a counteract stress (fillings or transverse thin walls

up to 2/3 height). Ancient builders reduced domes thickness in its upper side and increase it on its lower middle height.

Counteractancy can also be obtained by means of tightenings with timber or metallic elements which are good elements to counteract traction stresses, even auxiliary, during the construction process (until the thrusts has been counteracted), or as a reinforcement after an eventual collapse.

Arches

The brick arch is commonly used as a stressed element at opening coronations. It is a carefully plotted and mounted element in order to fulfill its role of a free space when it replaces some bearing wall.

Designed to withstand significant compression stresses transmitted by loadbearing walls or other building systems, the arch is usually made with regular and rigid materials to transmit stresses received to the jambs or stirrups.

Widely used in monumental and artistic buildings, it is also very present in the architecture of the traditional habitat; although smaller by size it has a meticulous and technical execution.

Because of their typology, there are two kinds of arches, the bricked up and those made up of voussoirs or book folding. Bricked-up arches are executed in the same way as the bricks are placed for any type of bond: horizontally, a stretcher or header bond, easier to execute than the second one: the vertical bond – screw or rowlock – because the brick has to be tackled radially by means of the arch curvature.

The design and the execution variations of the semicircular arches, segmented and pointed, more common in stonework, are also more easily executed with brick technique, which allows to go away from simple geometries, work without centring and, depending on builder skills, achieve new ways of solving the transmission of stresses in load-bearing walls. Some variations include: the stilted arches, rampant arches, pendant arches, horseshoe arches, etc.

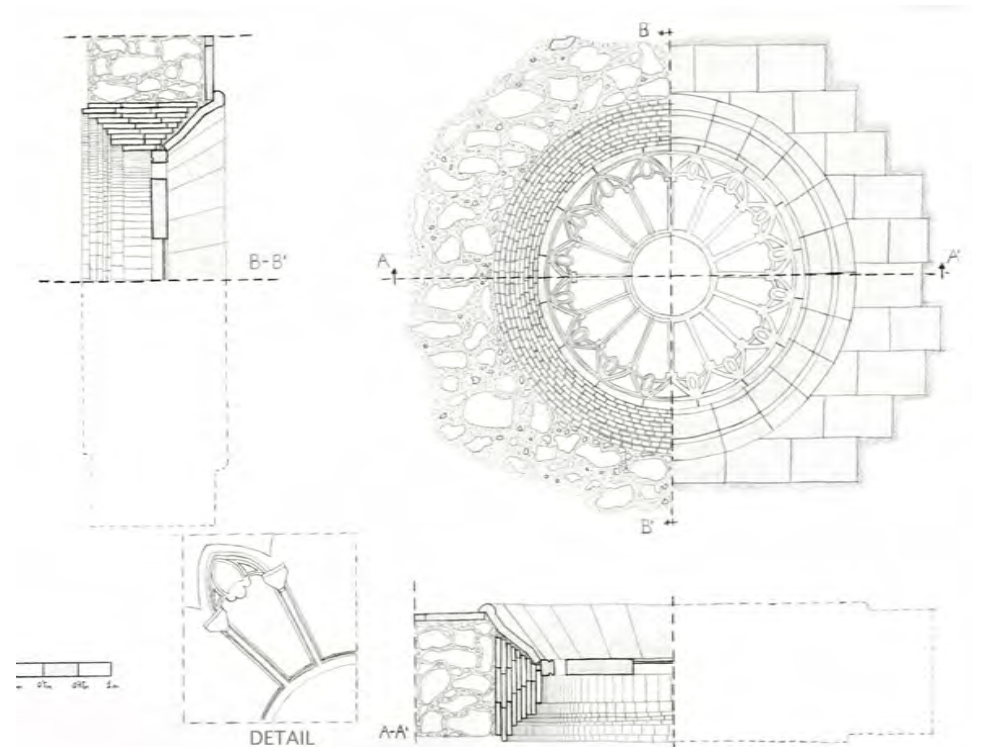

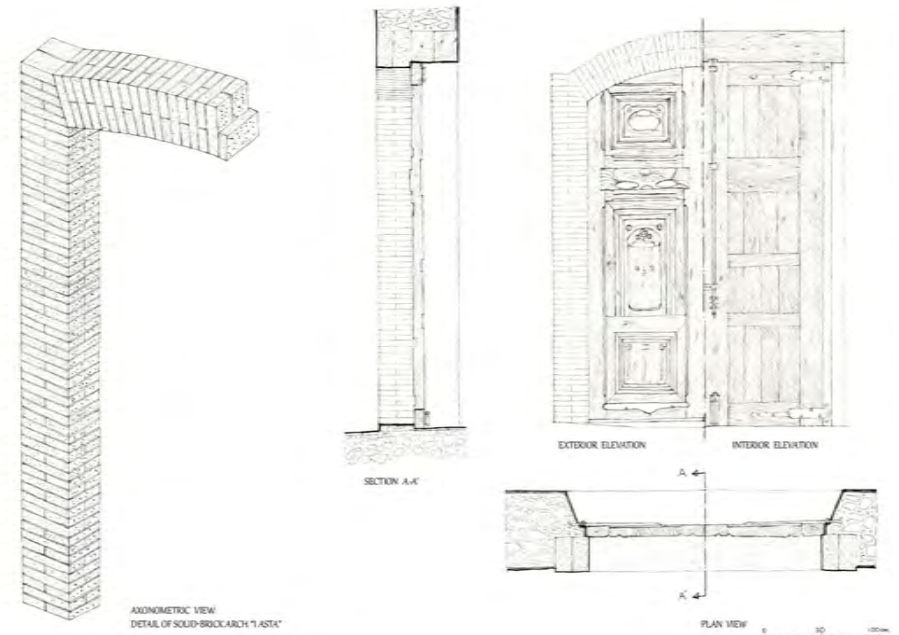
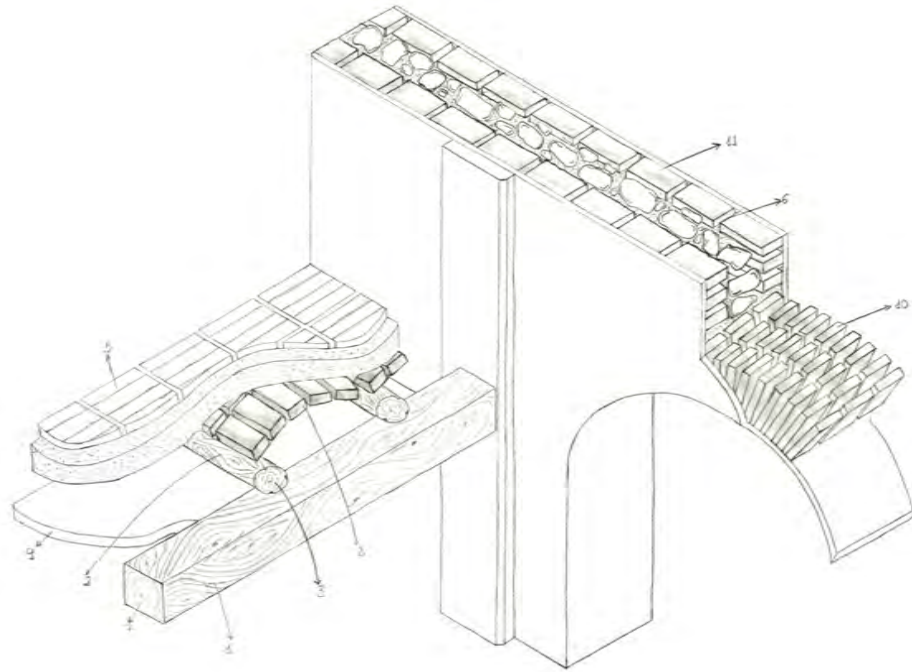

AXONOMETRIC VIEW
DETAIL OF SOLID-BRICK ARCH "L'ASTA"

BUILDING: C/DE LA FONT, 15

Vaults

The essential and rigorous condition to meet at the beginning of the construction of any kind of vault is to check if every support elements are correctly disposed, to counteract any thrusts which could derive from its own weight.

Once this condition is achieved and the scaffolding set up, every mark or meeting point between vault and walls should be designed and, if that is the case, the centring place correctly. Depending on each case, it will be advisable to open a chase in the wall to rest the first bricklayer in order to improve the ensemble and unload part of the thrusts.

The difficulty in constructing the partitioned vaults relates to the laying of the first bricklayer or «sencillado», since the rest of layers could be made by any construction worker. The «sencillado» can be executed forming arches or rings, depending on the shape of the vault. Due to brick lightness and the use of gypsum, swiftness harden agglomerants, the «sencillado» can be made without any formwork, only with the help of templates or guides. The vaults are made of two or three layers, but there have been also covered spaces with great lights with only a single layer.

The bricks, flat and rectangular, must adapt to the shape of the arch or ring, if possible, without retouching of the edges. Depending on the curvature, brick is tackled placing its long side or across but, if rectangular shape of the piece cannot be maintained at certain encounters, it should always be cut resulting in polygonal forms. There should not be much thickness at the mortar joints as excess retards the setting and causes loss of time. Each brick must be perfectly positioned to receive the following.

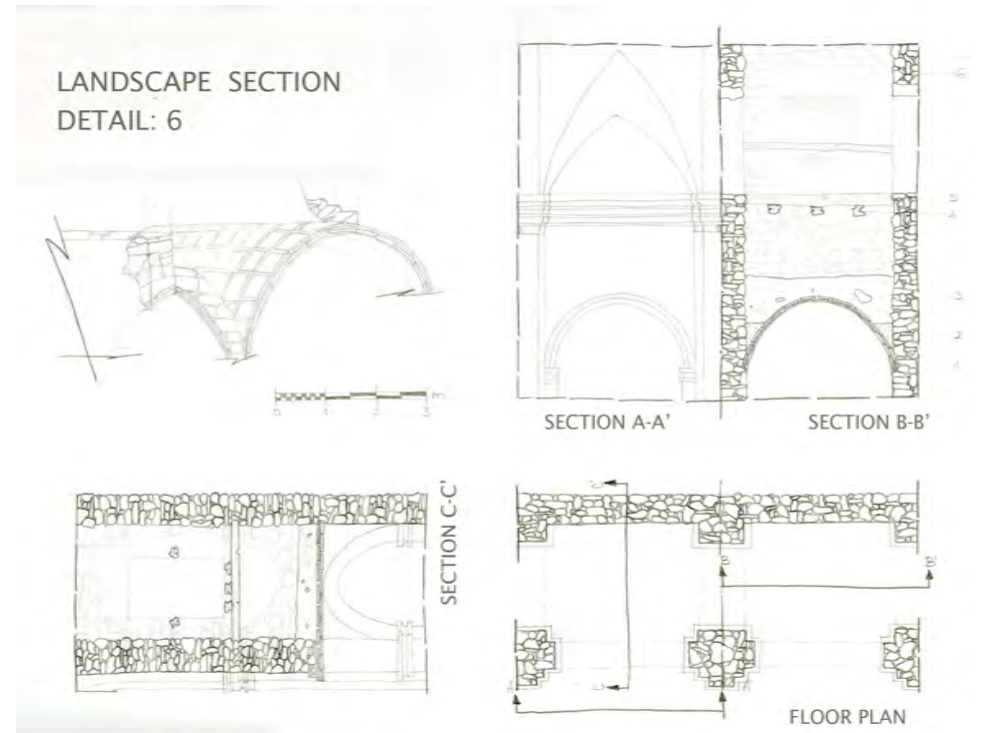

Jack vaults

The jack vaults is a building technique used for timbered shapes in which the jack vaults' function is to cover the space between two beams that support them. There are two kinds of gypsum jack vaults. One of them was elaborated by means of a centring made on-site of small boards of timber which polygonally shape the vault. The formwork covered the inner side of the floor and it was poured gypsum plaster mixed with medium-graded aggregate. This was leveled with the upper side of the joists – many times cylindrical logs –, thus achieving an uniform level. Because of the quick harden of the gypsum plaster, the centring could slide to execute the continuity of the jack vault or the rest of the beam fill. The size of the formwork was proportional to the volume that could contain a batch of gypsum and, in any case, the length of the joists.

The other kind of solution, subsequent to the above described, is the one which solves the cambered jack vaults with solid bricks taken with gypsum plaster, executed by crossed arches in relation to the joists.

The correct placement of each brick was achieved by a mobile mould with similar thickness than the size of a brick and a length which let it be supported or get stuck on the joist. Normally, these vaults were made of two layers but it is also common to use only one, after placement, the bricks essentially serve as a lost mould to the subsequent filling.

The space between joist is variable and directly related to the dimension or thickness of the timber; it can vary between 36 and 70 cm. To achieve supporting the jack vault on the joist, in the first case, joists were serrated longitudinally looking for roughness or small longitudinal slots in which to hold the mortar. In the second case, the joist used to be supplemented with a strip, leveled with the joist's inner part where it supports the bricks.

In both cases, the thickness of the jack vaults, in its central point, is very thin, between 4-8 cm.

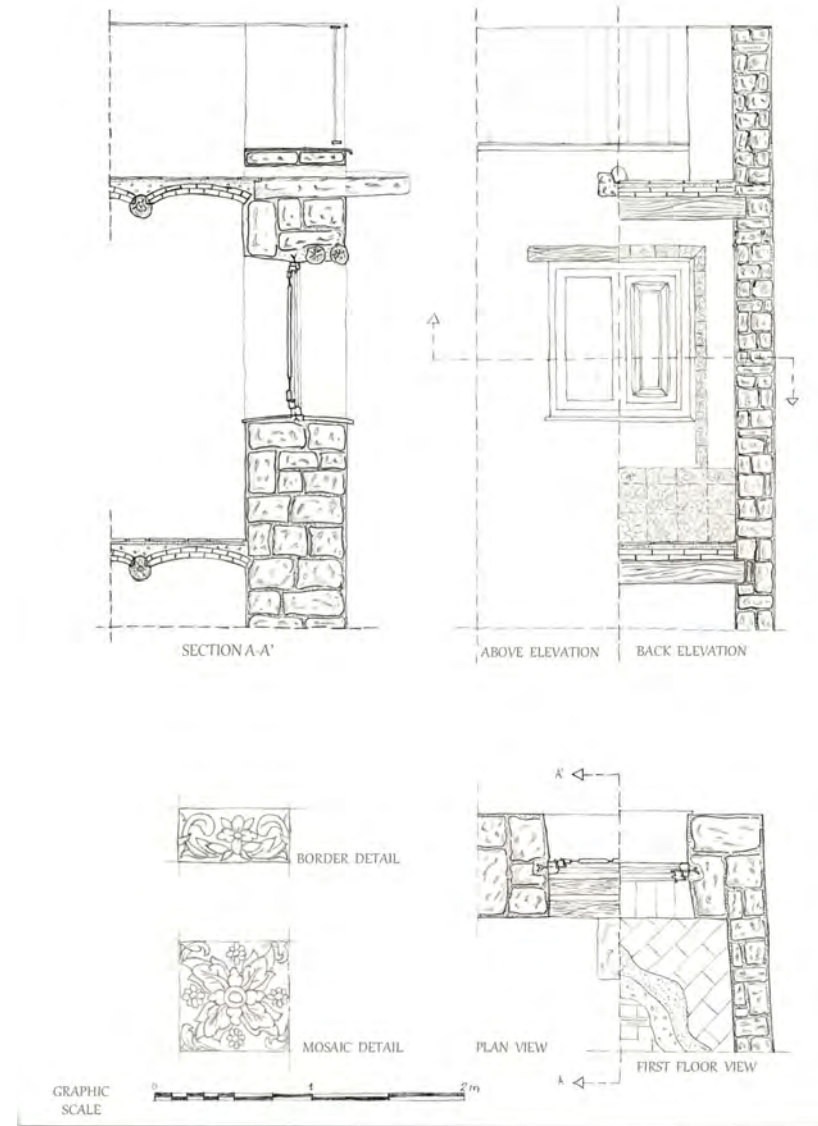

STABLE FRAMEWORK PRINT 5

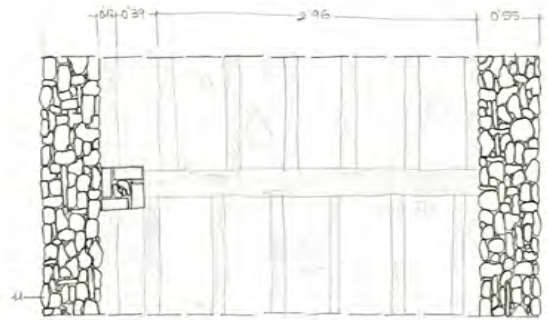

SECTION
A-A'

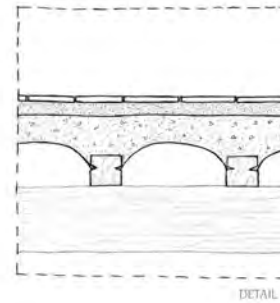

DETAIL

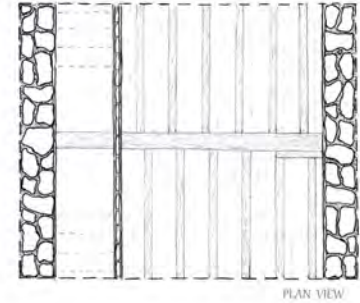

PLAN VIEW

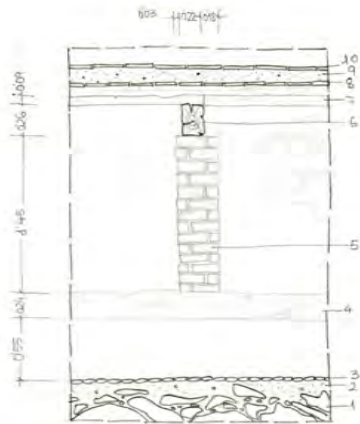

SECTION
B-B'

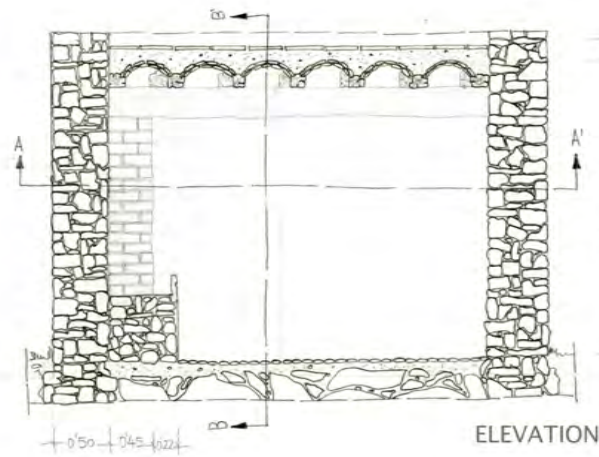

ELEVATION

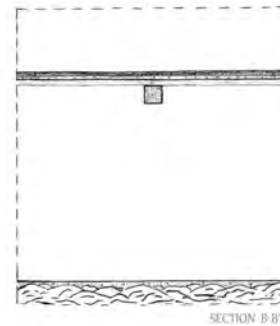

SECTION B-B'

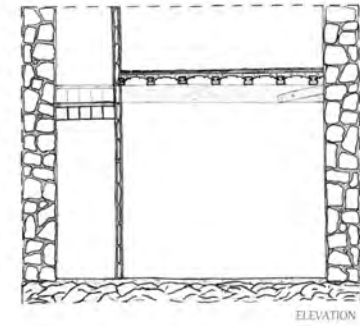

ELEVATION



GRAPHIC SCALE

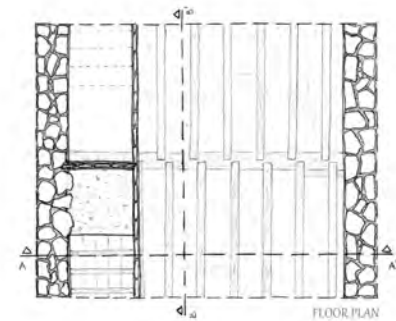

FLOOR PLAN

Stair vaults

The more widespread use of thin bricks vaults is for the construction of the supporting structure of stairs. For that reason, independent vaults generally are disposed that are fastened and rest on the lowers, reaching the height of each floor flight by flight.

If we visualize the vault in a cross section, the generatrix is straight in the case of continuous spiral stairs and slightly arched, and tilts towards the walls of the stairwell, in stairs divided by several flights. The generatrices bend against the wall forming the splay. In the longitudinal direction, the directrices of the vault are curved.

The layout of the longitudinal curvature is drawn on the walls of the staircase «by instinct», with the help of a flexible strip of wood, a metal rod or heavy rope as a catenary. There should not be opened a longitudinal chase in the wall, as the natural flexing of the vault (attached to the retraction of the mortars) forces the embedded arch and can break the vault.

The vaults of stairs are made with with three layers of brick vaults, although it is more common only with two. In the first, bricks are placed with plaster and without the aid of formwork, placing the remaining with lime or cement mortar and discontinuously between the different layers.

The first vault of a staircase generally rests on a solid with its respective foundation and on the other end leans on the opened chase on the wall. In implementing the second section, the first layer will be resting on the second layer of the lower section, and so on.

In the design of the vaults, there should be taken into account:

- To limit the overloads, giving little curvature to the vaults.
- To consider that the vault, besides serving as a support for steps and landing, must receive the upper vault.
- To look for, as far as possible, loads symmetry on both sides of the closest point to the tangency, between the arch directrix and the bottom line of steps; between the initial support and the final support parts of the vault.

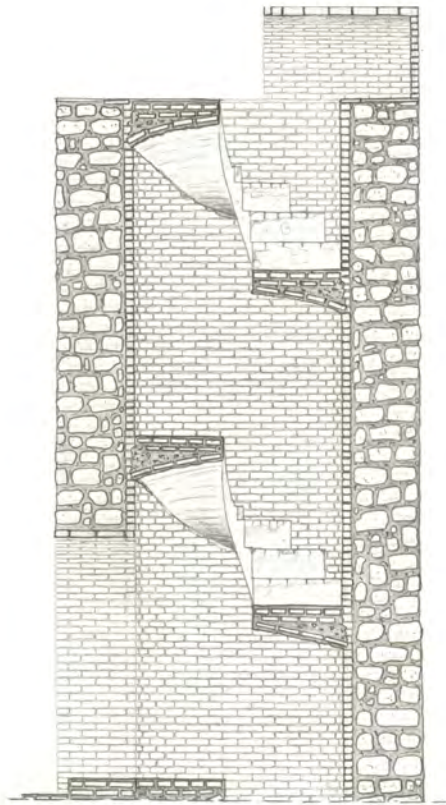

Section A-A'

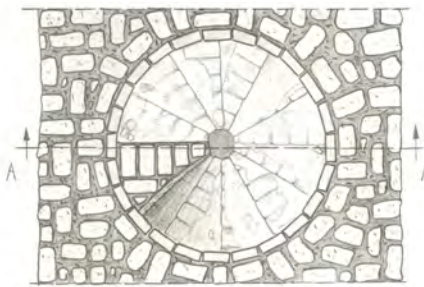
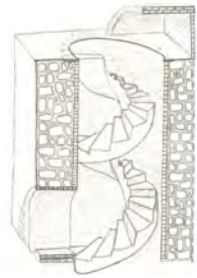

Horizontal section

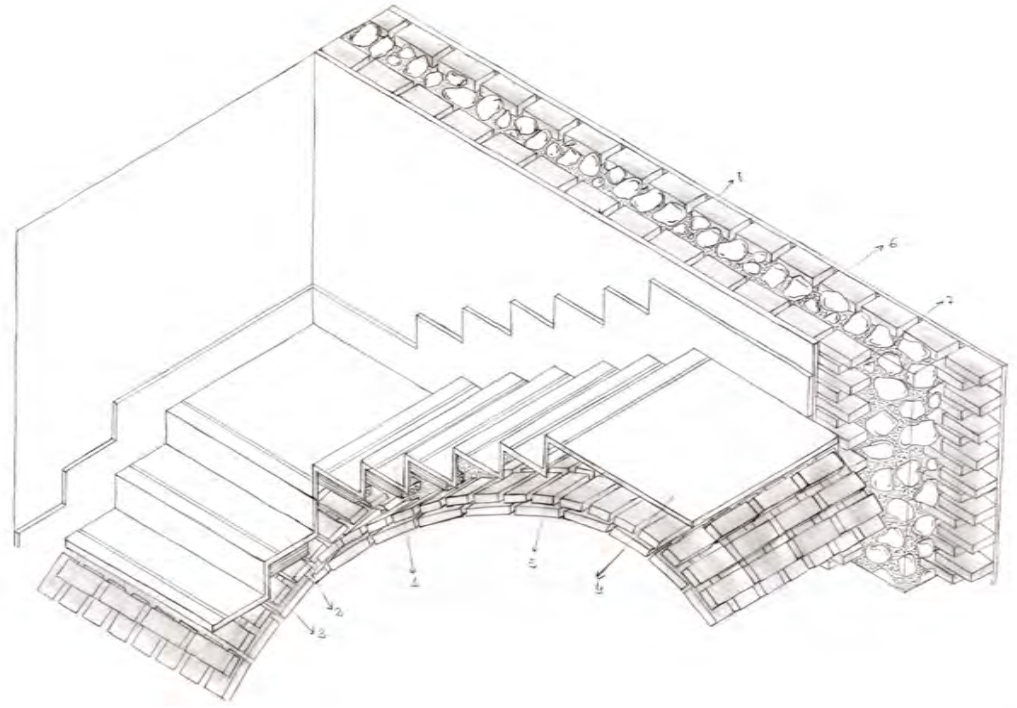

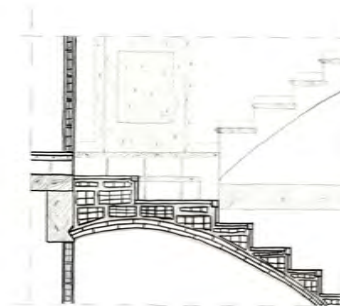
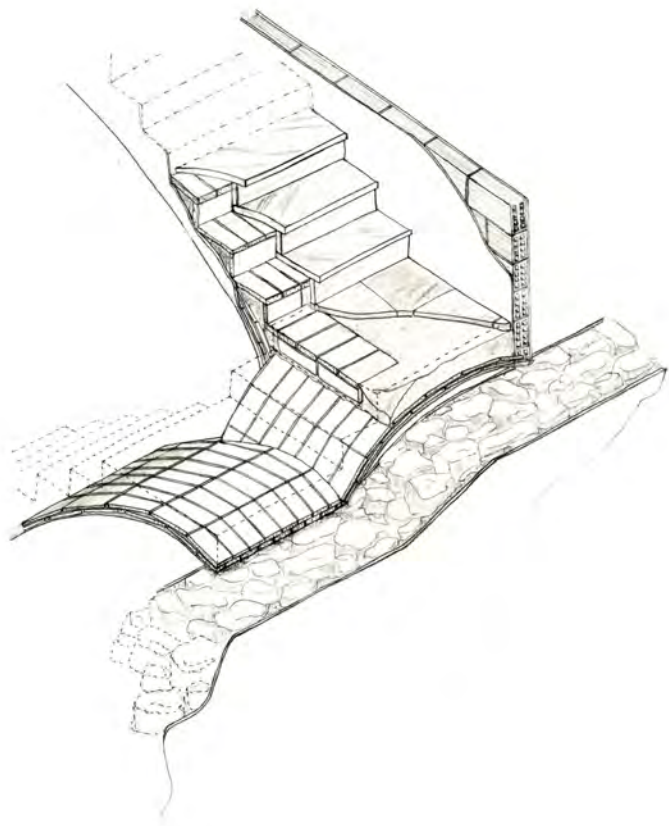

Section A-A'

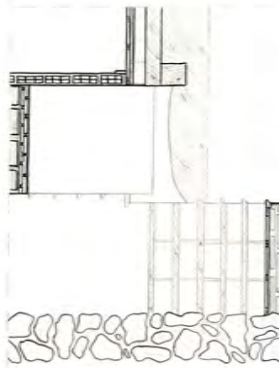

Elevation

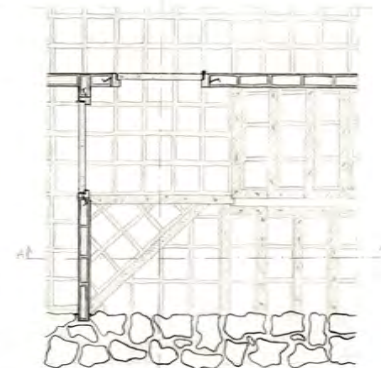

Floor plan

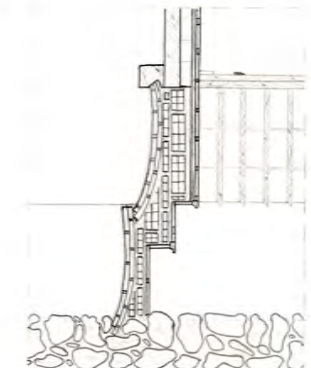

Section B-B'

Domes

Domes are covering structures – hemisphered, pendentive, sloping... – adopted to cover polygonal spaces, normally squared.

They can be erected on arch-shaped openings that define the space to be covered or through clearings made in the face of the walls that encloses the space by means of squinches or pendentives. These are concave triangular building elements cantilevered from the edge that make up the walls or the arches, to the ring, the basis of the circular dome (pendentive) or until the edges of the polygonal vault (squinch).

The characteristics of the brick allow working without formwork and the fixation of the workpiece, in its final position, is virtually instantaneously because of the quick-setting of gypsum plaster. The order of placement of the bricks is responsible for the natural order of numbering, being followed by ring rows until closing the dome.

The first lower third (dome spandrel) has to be filled or cladding applied to counteract the thrusts transmitted, in a radial way, from the upper side of the dome. The counteract is not an added weight on the dome and does not increase the thrust, the counteract works as a mass whose weight acts as a completely vertical stress to bring down the horizontal part of the stresses coming from the upper side of the dome. If horizontal stresses are not counteracted the dome probably breaks horizontally on its first third.

Another technique for building domes consists in constructing the corresponding arches (ribs) and then cover the cloth with cambered vaults of bricks (web) placed horizontally – «bricked on flat» – and in the shape of an umbrella, showing its ribs.

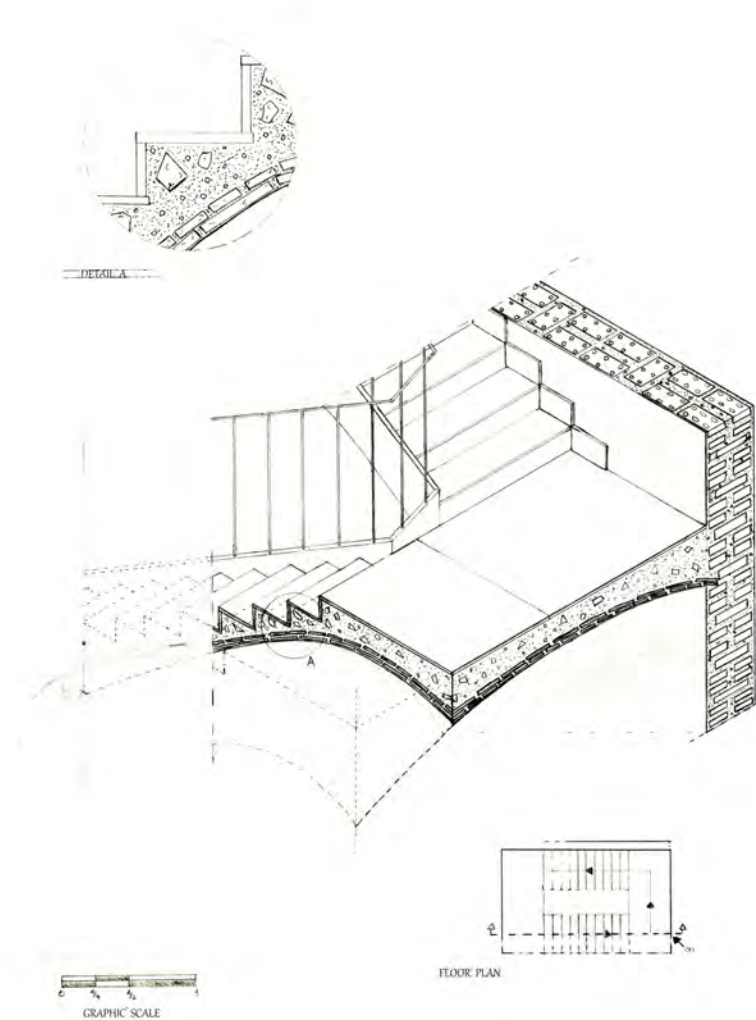

Both domes and vaults normally are covered by coating layers and it results complex to analyze the constituent material.

As much domes as vaults normally are covered by coating layers and results complex to analyze the constituent elements.

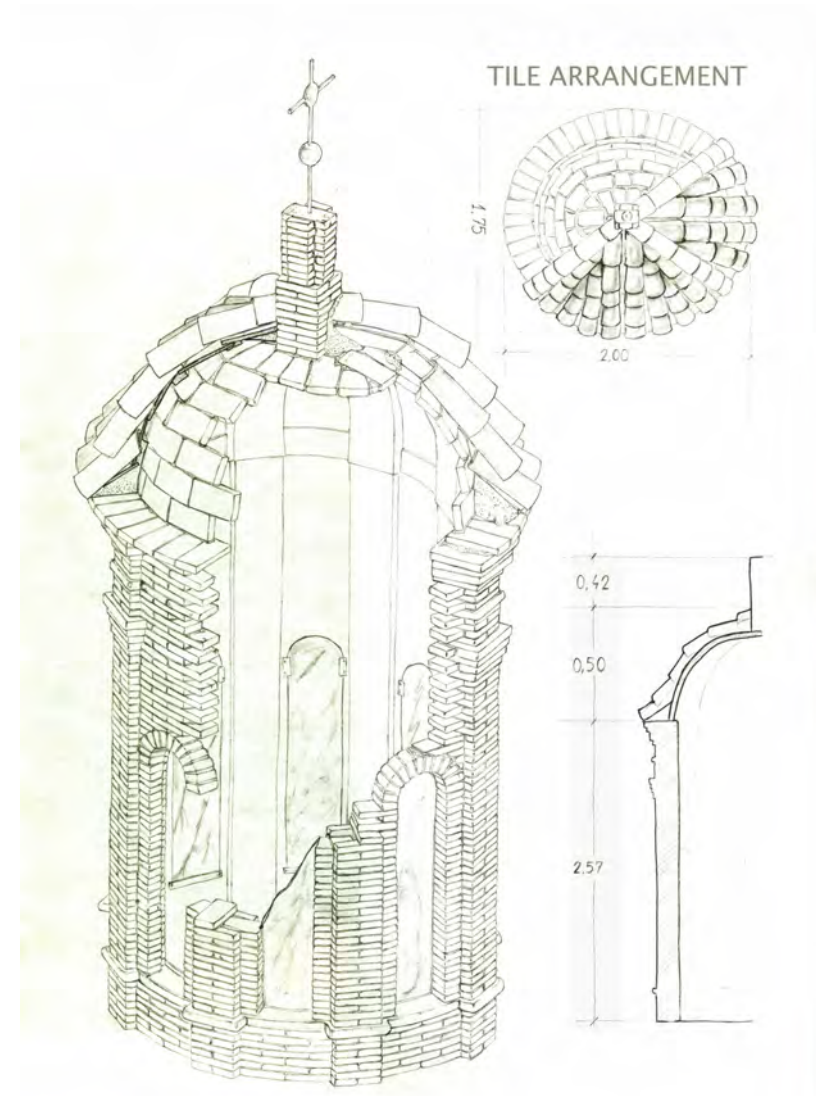

Wooden framework

Floors

The wooden slabs are structural elements, generally horizontal, comprising of three layers which transmit the stresses stemming from the usage and self weight on the vertical structure of the building, usually load-bearing walls, which in some cases and because of necessity provide an opening – of short or large dimensions –, resulting in the form of an arch or lintel.

The first layer is composed of the elements which delimit each bay: the beams – squared wooden elements subjected to bending stresses. The size of the beams usually range between 20-30 cm depending the type of timber, the length and the space to cover. Sometimes, in its place, the other two layers that make up the framework can lean on load-bearing walls – vertical structures subjected to compressive stresses.

The second layer is composed of joists, or elements that lean on the timber beams, in cylindrical, quadrangular or rectangular form, whose size ranges between 8-15 cm, also depending on its length and the type of timber, its length and the space to cover. The joist can transmit loads directly to the walls, to an arch, or rest on a timber beam.

The third layer is the one that transmits the forces to the joists and may be of various types. The most immediate model is visible from both the underside and from the top of the slab itself – floor boarding or paved flagstones – with enough edge so parts are subjected to bending stresses. More elaborate models were built using the technique of small vaults, a construction system which works with compression.

In the mid-nineteenth century some wooden structures were be repaired or replaced by metallic profiles, and in the twentieth century reinforced concrete structures were highlighted.

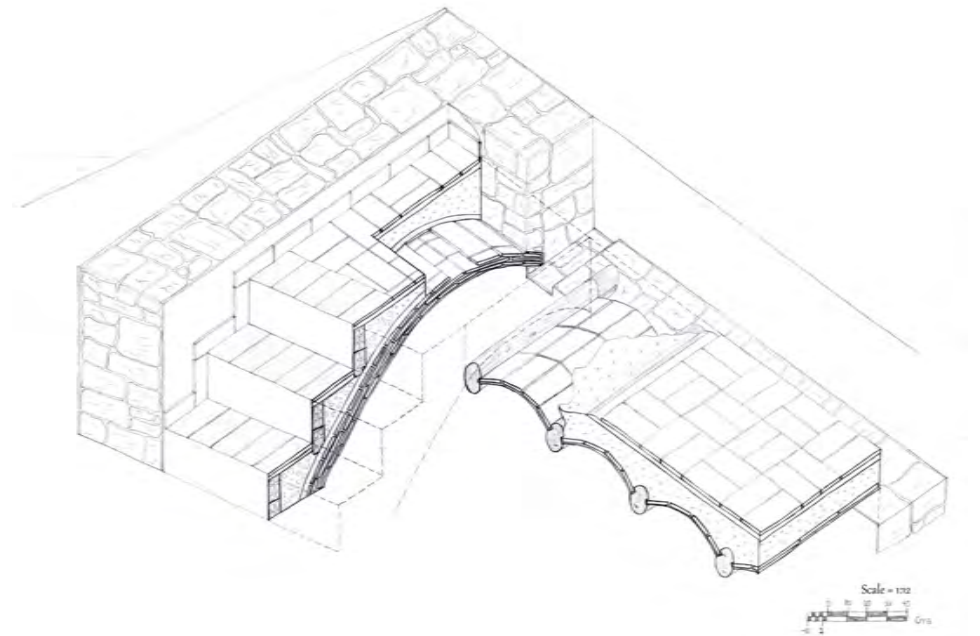

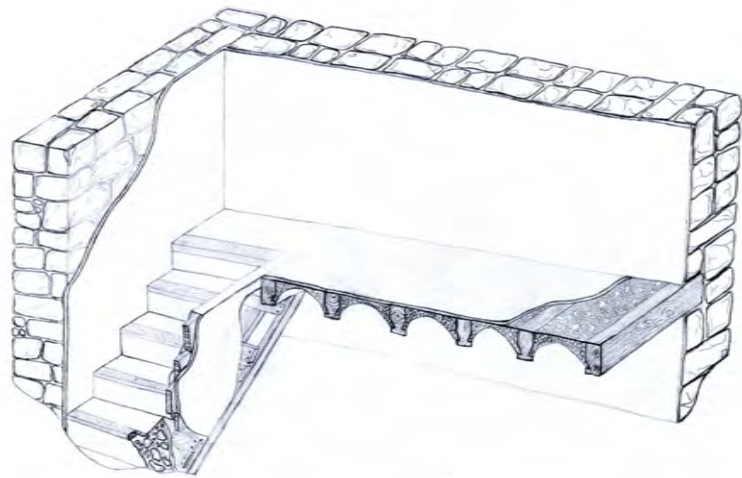

ENCOUNTER STAIRS-FRAMEWORK

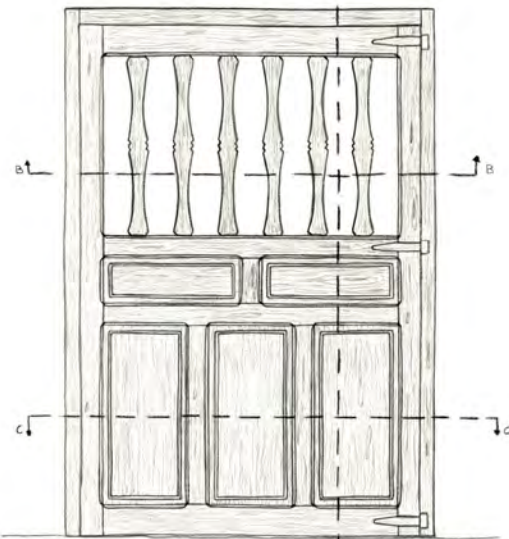
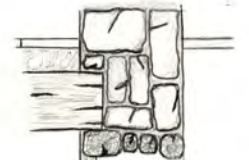
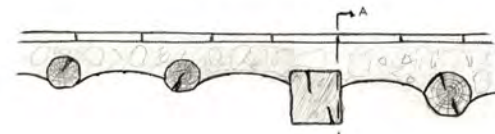

FRONT ELEVATION

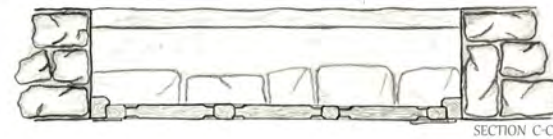

SECTION A-A

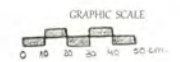

Stairs

The stairs made with wooden supporting structure are common in mountain areas where the availability of timber generalized this solution against ceramic elements which are more immediate and cheap in coastal zones, with alluvial soils where there is a good supply of sediments and clay.

Quite the opposite from stair vaults, in the wooden framework the slope is uniform and rectilinear. The timbers are usually visible on the lower surface of the stairs, and they can be used depending on the economic resources and availability. It is possible to find from two to three units, on which flagstones lean to shape the inclined plane to build the steps, until using the units needed to cover the entire width of the section and thus having the supporting plane solved.

Like the bricked-up vault staircase, these timber pieces lean on a solid section on its lower part and, on its upper side, are embedded in a load-bearing wall or nailed on a beam – always on elements with enough resistance. As with any type of stairs, both supports, both the top and bottom, prevent the stair movement –both work as counteracts– before the stress transmission owing to the self weight and usage load.

The steps were executed, from the lower to the upper flight side, using a board, placed vertically with the same width as the flight, to serve as formwork for pouring mortar and rubble – building remains. After the first step, once hardened, it would continue carrying out the remaining steps.

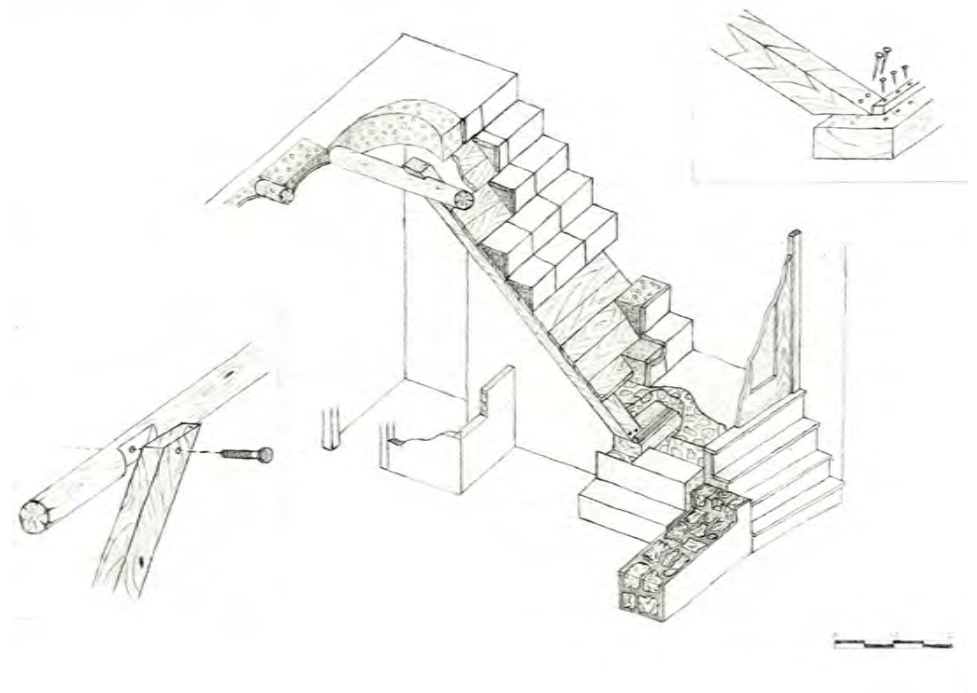

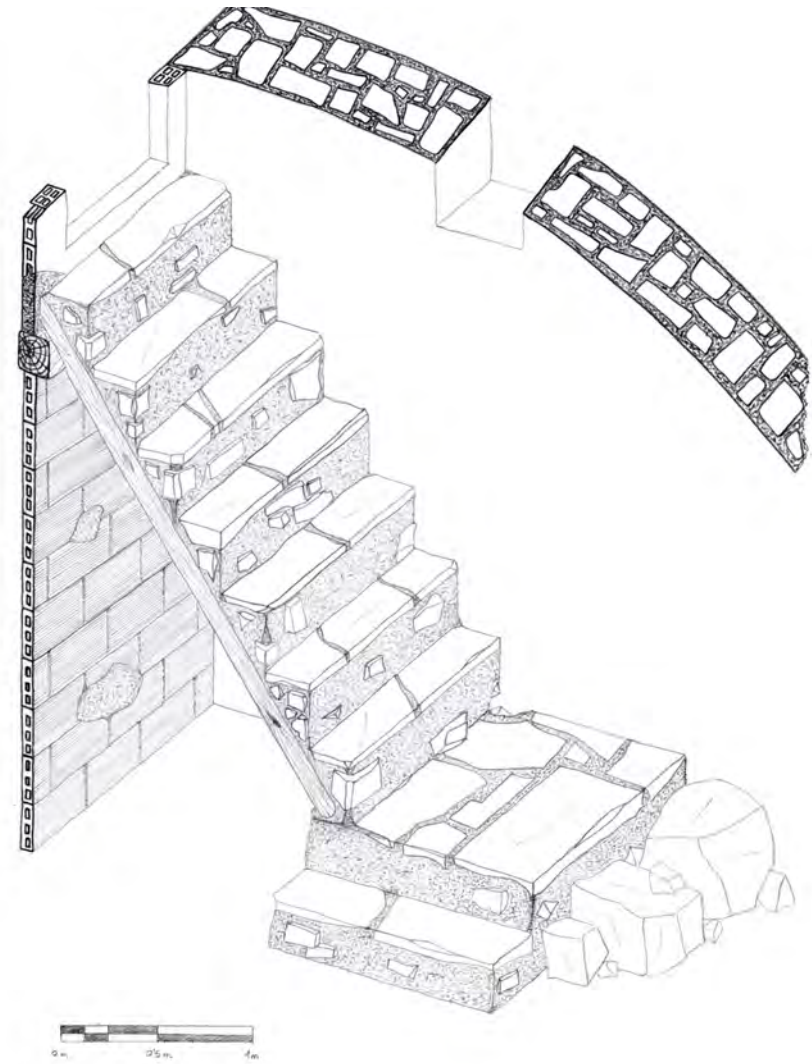
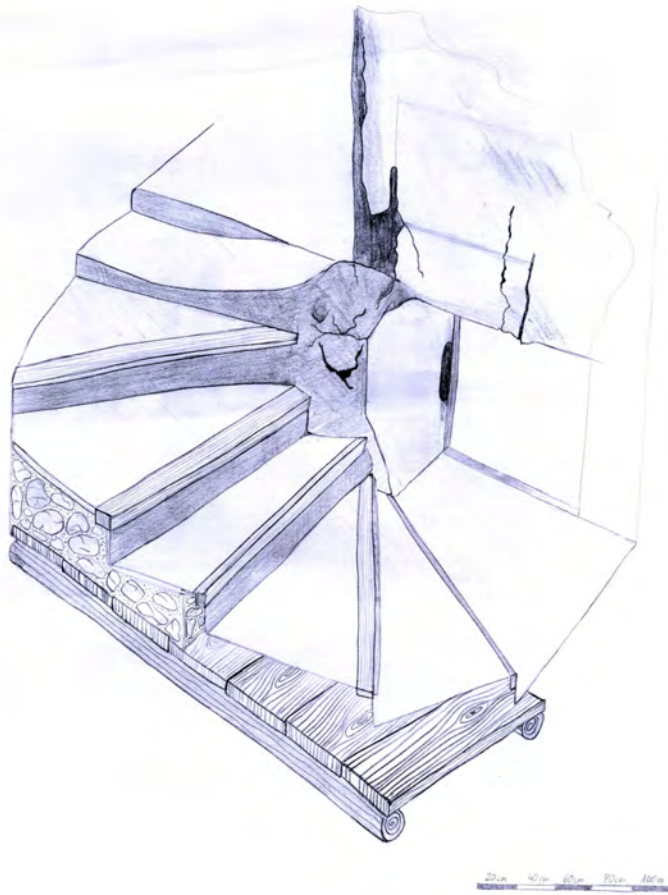

Roofs and Slopes

The shape and the system of building a roof are determined, in addition to aesthetic considerations, by practical needs: to provide easy exit for rainwater and snow, to the use of space as a walkable place, etc.

The two most common typologies are the sloping roof and the flat roof. In both types, wooden frameworks deal with the mission of support.

In the sloping roofs, the number of slopes, the gradient and coverage material determine the final appearance of each building. Joist framework characteristics correspond to the ridgepole tradition. The simplest system is formed only by embedded joist resting on the perimeter walls and the ridge beam.

The roof is built by means of an unidirectional framework of squared joist or cylindrical trunks, rarely exceeds 5 m in length, and the intermediate space is covered by bank cane braided or wooden boards. Another more elaborated solution consists in the placement of strips on the joists on which the solid bricks layer taken with plaster rest.

Finally, over the brick surface laid a bed of mud or lime mortar on which the tiles were placed.

This framework sometimes forced to place wooden taunts embedded on the wall. The assemblies are relatively simple: a medium tree, simple notches, spiked or sometimes a single bound.

In the majority of clustered buildings in settlements, the roof use to be gabled and its ridge is arranged in parallel to the building facade to drain water without affecting the adjacent housing.

The roof gradient varies between areas of low rainfall (25/30 %) and high rainfall and snowing (30/40 %) as a higher gradient is related to eject faster snow and rain water thus avoiding the danger of collapses and filtrations.

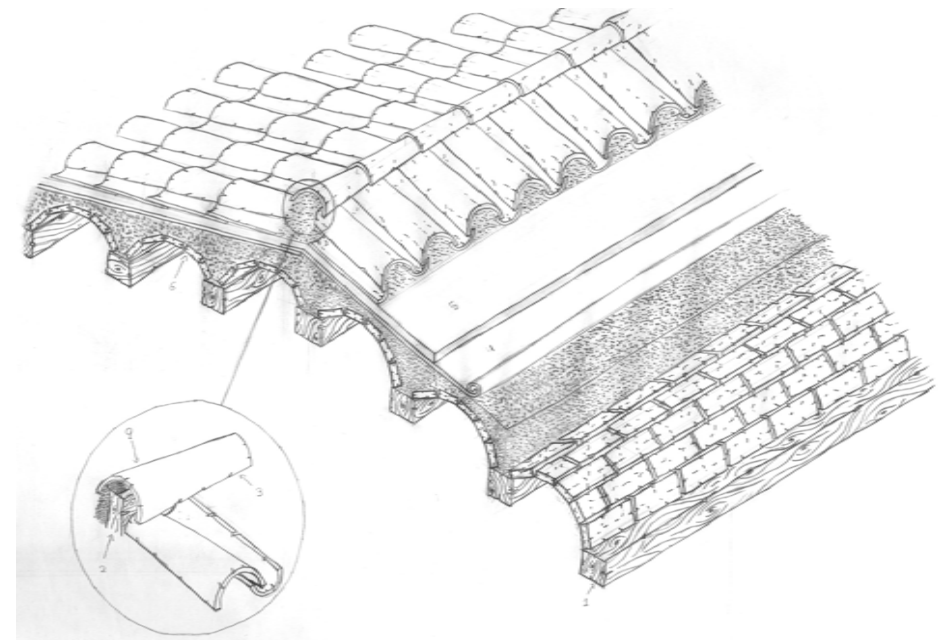

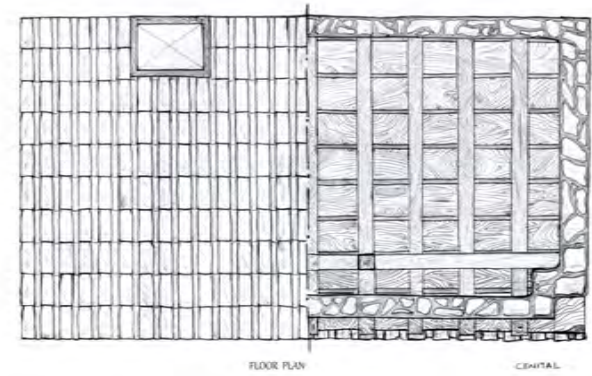
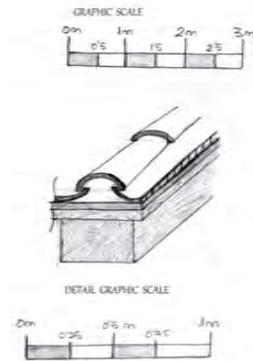
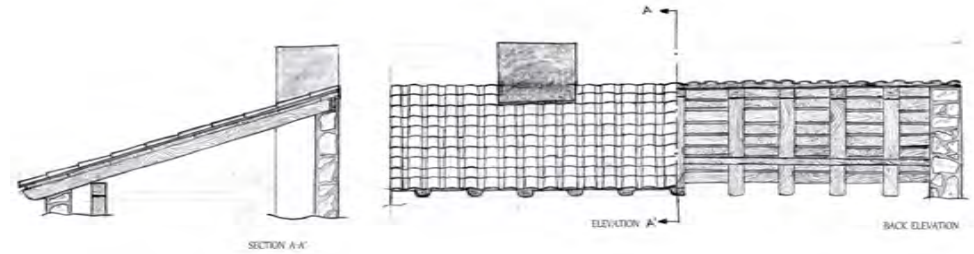
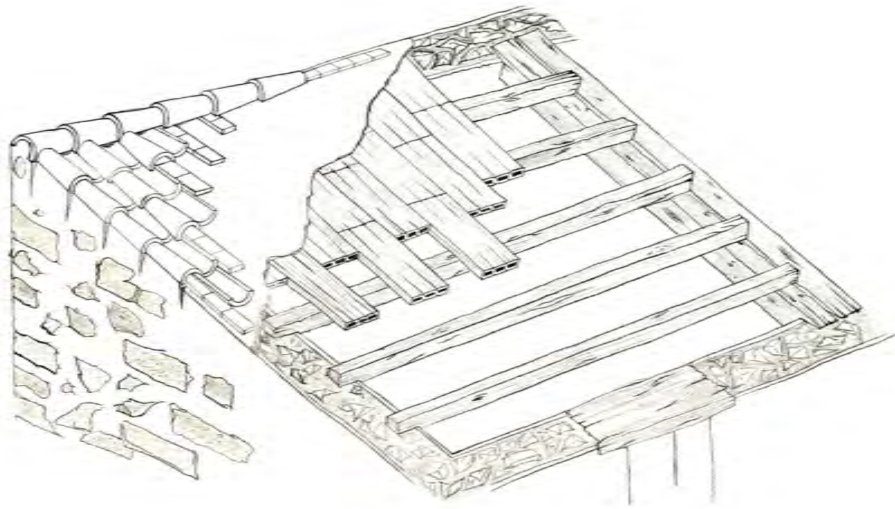

Roofs - Eaves

The eave is the horizontal perimeter of the roof, its lower part which overhangs from the wall to avoid contact between rainfall water and the facade.

In most houses it is simple, built with solid bricks shaping a cornice which shows itself in a different size and form depending on the number of ceramic pieces arranged, the courses and their distribution. In some cases roof tiles or brick rows are inserted in diagonal form. These pieces can also appear monochrome or polychrome, mostly following geometrical sketches.

Another kind of eave is the one executed with the own roof joist which overhangs across the wall, following the same roof gradient and solved with a simple wooden boarding with one or two courses of timber on which it will receive the first roof tiling courses; normally saddled up if the slope has an excessive inclination.

Perhaps some more complex than the previously mentioned are those eaves built with independent joists from that make up the roof tail, these are placed completely horizontal and arranged in a cross beam, parallel to the façade, completely embedded into the wall, by way of a sleeper, placed on the lower surface of the wall to prevent tipping of the protruding cantilevered joists. On the lower side of the eave, over the joist, a wooden boarding is placed, mostly decorated with carved friezes or geometrical forms. Joist and beams also can be decorated with border paintings or carvings.

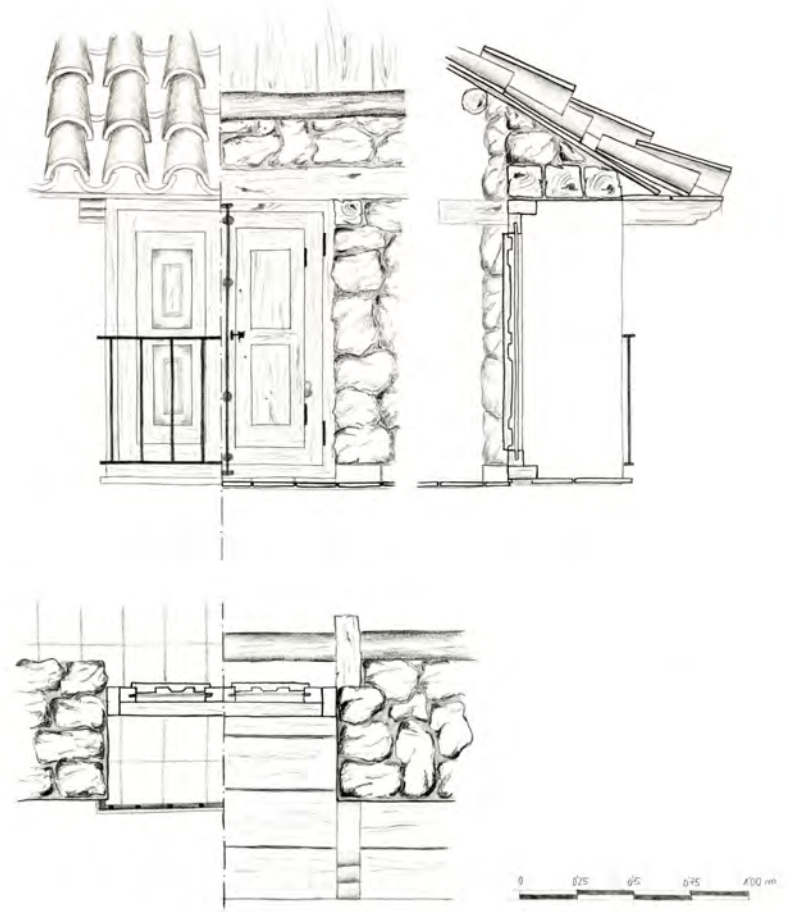

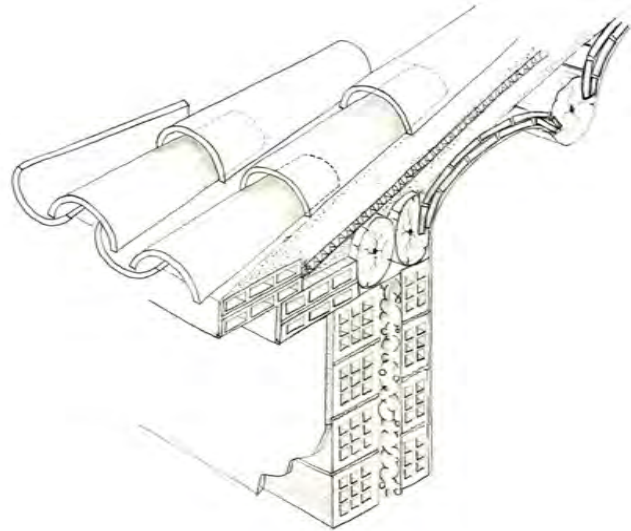

CONSTRUCTION DETAIL: ROOF

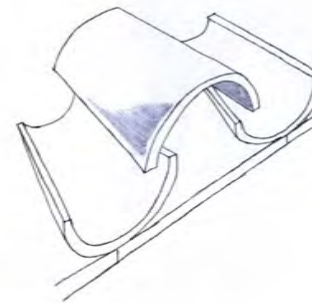

CORRECT
TILE PLACEMENT

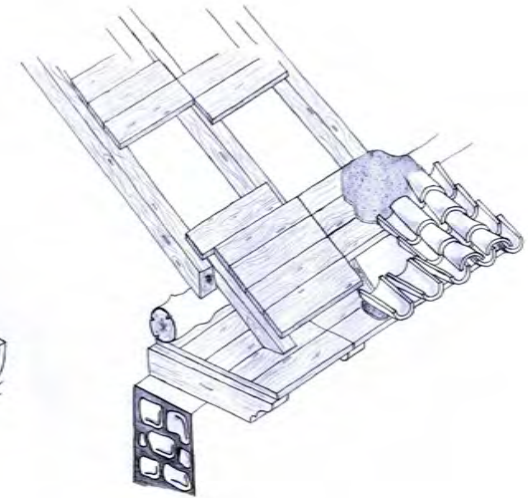

Covering

In primitive construction, pitched roofs were resolved with a covering of straw or wood shingles, and sometimes stone slabs. While the straw was placed on a plane formed by a network of braided cane, the other two materials rested directly on the roof structure itself.

The fired clay has been used since ancient times in the covering of buildings because of its conformability and its resistance to weathering. The curved tiles, those employed in traditional architecture, confer impermeability to the roof by its overlapping placement and because of the slope of the framework.

Curved and plain tiles («roof and cover tiles») are placed to pour the water one over the other, seated on a bed of mud spread over a boarding of timber or reeds nailed to the joist structure. In most cases tiles are dry-fixed, just interlocked between them traditionally with sand mortar or lime-poor mud to avoid being lifted those more exposed to the prevailing winds and those in the roof perimeter zones. Sometimes the tiles were placed simply taking clay mud. Stone slabs are often seen on the perimeter of the cover with the function of preventing the tiles lifted by the wind.

To tile the roof covering, curved and plain tile courses are drawn from eave edge. Once roof tiles are correctly distributed along the eave builders start tiling upward slope. Roof tiling continues placing cover tiles over roof ones. The ridge will be the last element to build up the roof.

Manufactured tiles are clearly distinguished from industrialized the first ones being much more favorable to the elements by sealing its pores by years of exposure to the elements. The tile takes on reddish or yellowish tones according to the sort of clay used to manufacturing it.

The flat roof with slopes of less than 5 % to evacuate the water, initially was finished off with argillaceous soil and afterwards with terracotta, a type of deck typical of the Mediterranean coast.

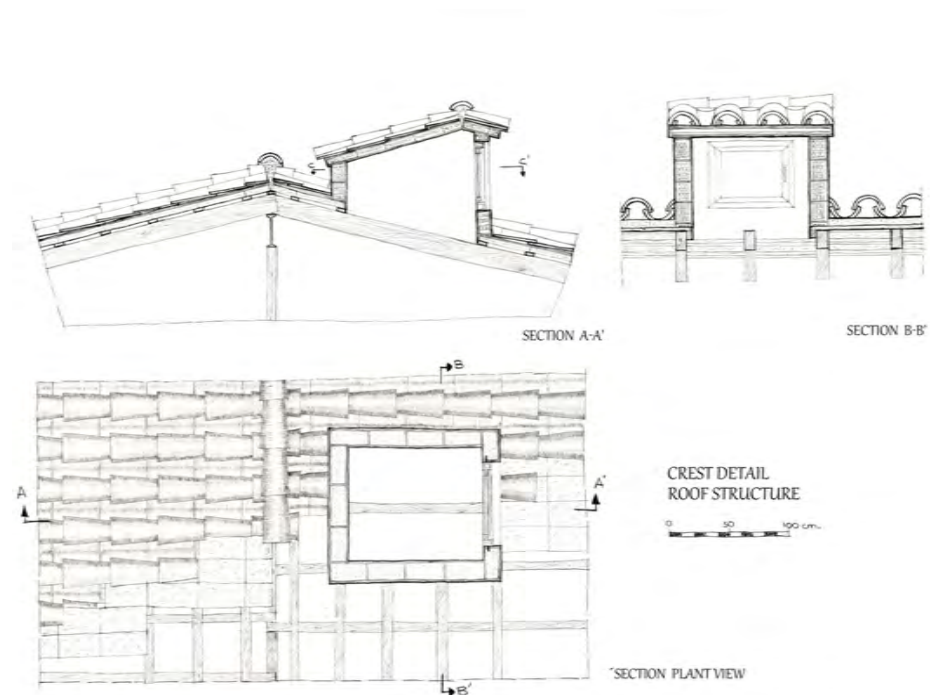

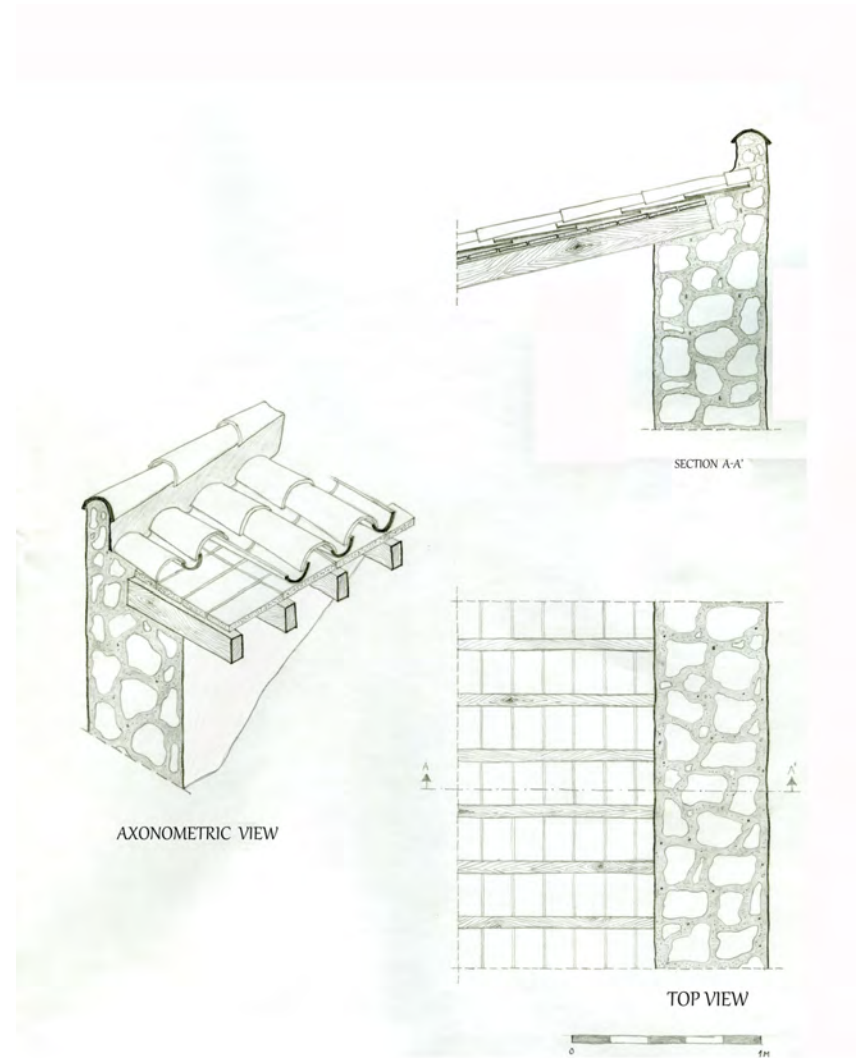
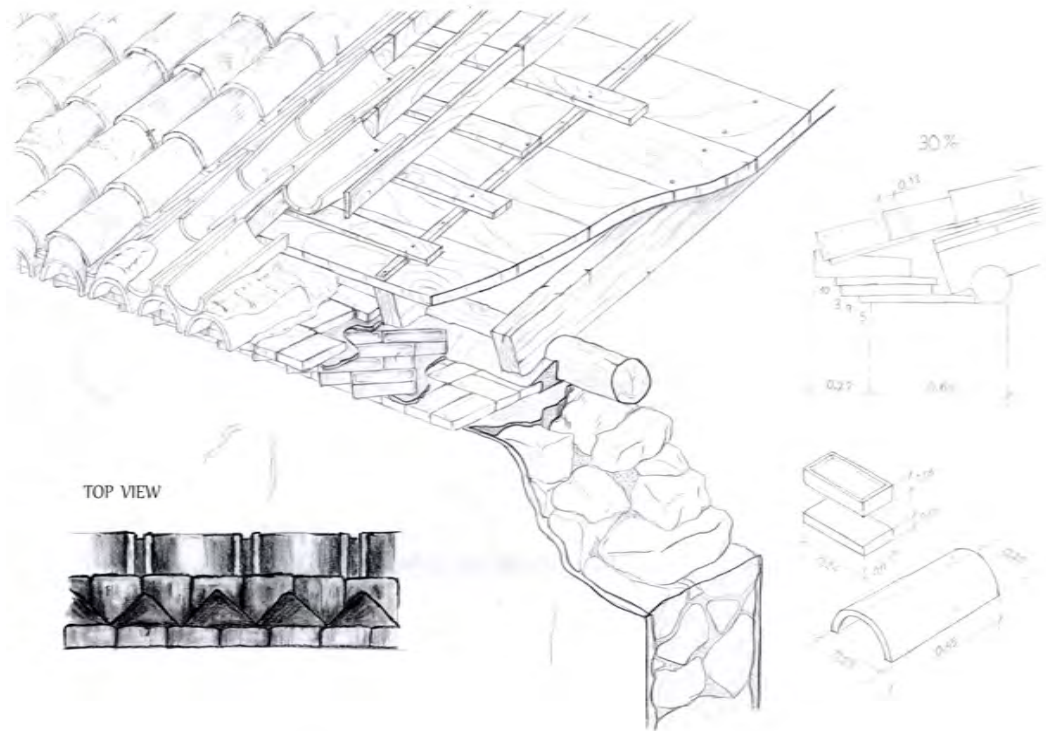

Vertical Coatings

Traditionally in vernacular architecture the application of a coating on the exterior walls has been motivated by the protection which can be afforded by the constituent material, and hence the durability of the stonework, against the atmospheric elements and not as a decorative claim, although it has often been the base of decorative finishes.

Plasters, usually lime mortars, are presented in varying degrees, from the fairly thick plaster that covers the entire support until the plaster that covers the gaps on a masonry wall and allows the appearance of the stone protuberances. It is also possible to find stonework in which the joints are levelled to the external face of the wall confining the coatings to the perimeter zones of the openings of the housing.

Gypsum mortars have also been frequently used in exterior coatings, particularly in areas where raw material was abundant, as this type of plaster was coarse and resistant to moisture.

In old buildings that have not been maintained, the coating has reached the point of deterioration that has completely disappeared and only a careful look reveals its previous existence.

The whitewash, as the last layer in the building coating process, can still be seen in many constructions covering completely the walls, in others only covering the perimeters of windows. Its use is related to hygiene because of the whiteness and disinfection provided by the quicklime. The whitewash can be applied coloured with the addition of some mineral pigment being usual the traditional «azulete» (bluing or coloured whitewashing).

The stucco is a kind of decorative covering typical of representative buildings and therefore less common than before. It is a very thin coating, never more than 3 mm at a highly controlled dosage with fine particles size as aggregate applied in one or more layers.

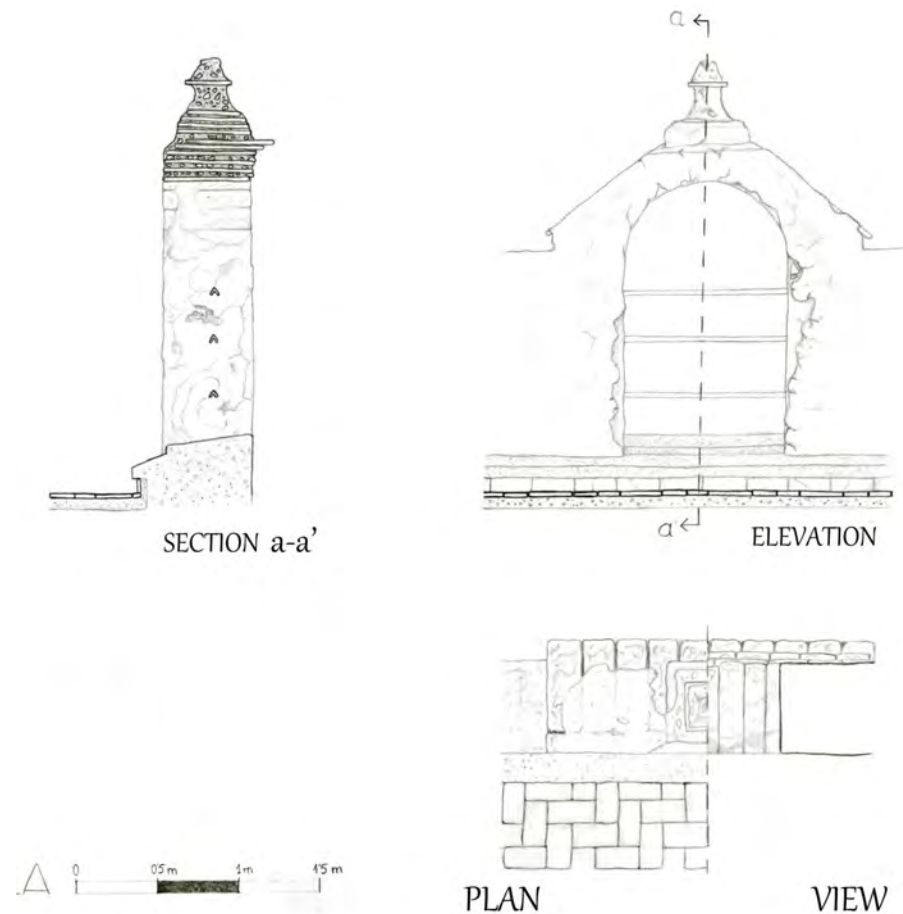

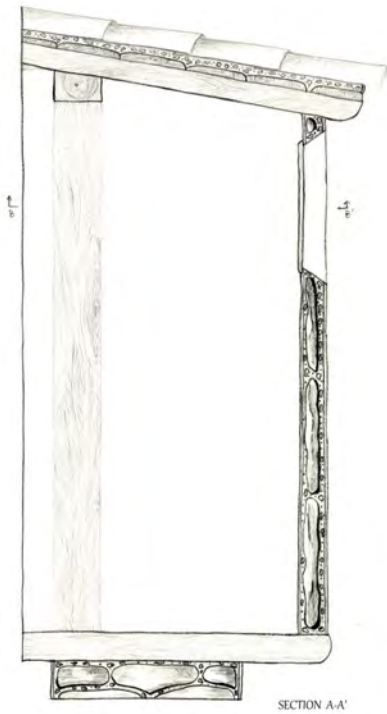
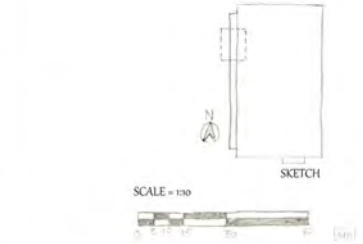
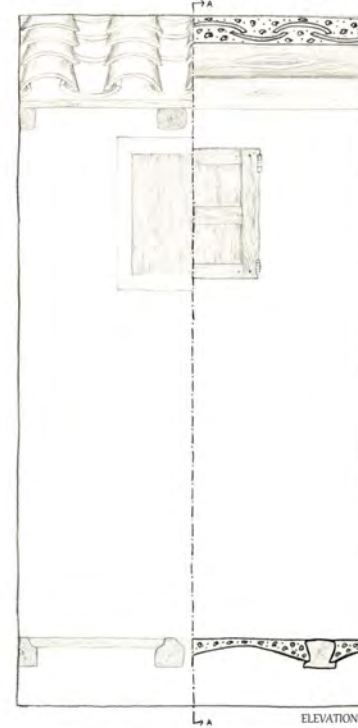
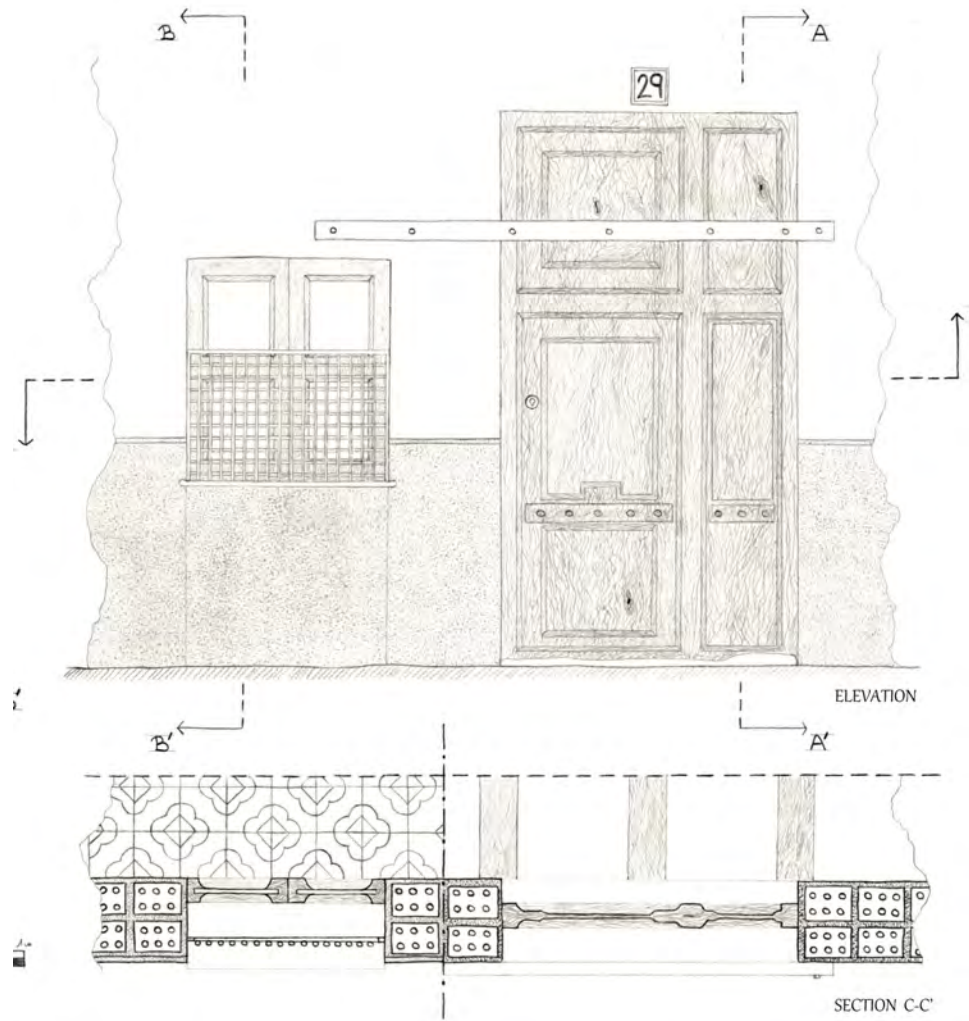

Horizontals Coatings

On the ground floor, in the part used for housing, the pavements were usually done with lime mortar with an addition of gravel and gypsum. The mortar was spread over a previously compacted earth layer. The finish layer, if it was properly executed, was smooth and impermeable, as was done by applying above the almost forged mortar, a plaster composed by lime, gypsum and a little bit of fine sand, by way of burnishing. This system is locally known as «trespol», a word that has finally spread to designate any flooring of a house.

In homes whose owners enjoyed a healthy economic situation tile floors with flagstones were common, settled on a mud mortar. The most humble homes frequently recurred to compacted soil mixed with a small amount of lime.

In the hallways, entrance areas and spaces for the animals, the most common was the pavement with river pebbles, the «enmorrillado», a continuous pavement made with small river pebbles, placed over a clay, sand and lime mortar, the same way as the flagstones pavements in a more or less regular form, and also the compressed earth pave.

On the above floors of the building it was typical to find the above mentioned trespol flooring, the flagstones pavement or the widespread of lime mortar, although the last use to be relegated to temporary access zones such as the floors under the roofs.

Ceramic tile was very common at the end of the 19th century and the beginning of the 20th century, especially in its traditional red and white colouring. Due to the spread of manufacturing the tiles diversified its size, colouring and decoration. Today its possible to find a multitude of flooring typologies, from ceramic tiles to hydraulic tiles, which also spread at the beginning of the 20th century. Paving with tiles over small vaults or a wooden stage frame is implemented by means of spreading out a 3-5 cm regularization layer composed of lime mortar and afterwards placing the pieces with holding mortar.

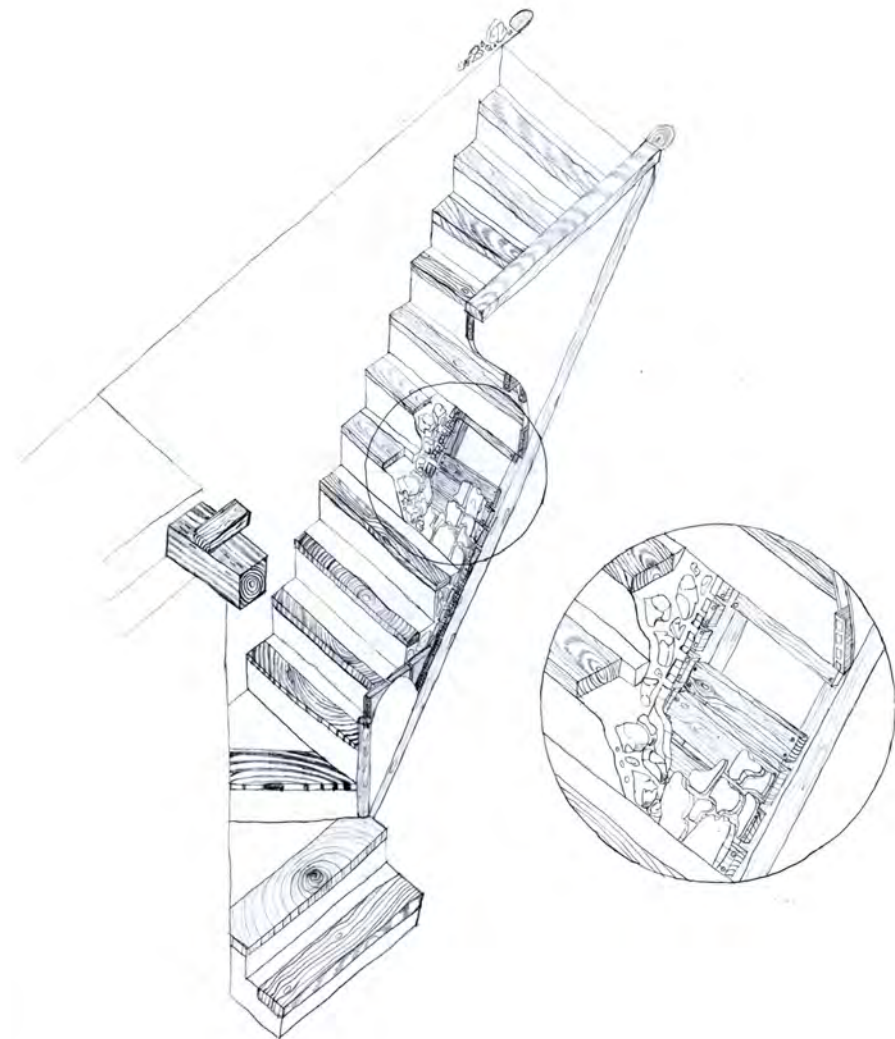

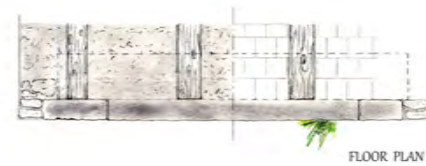
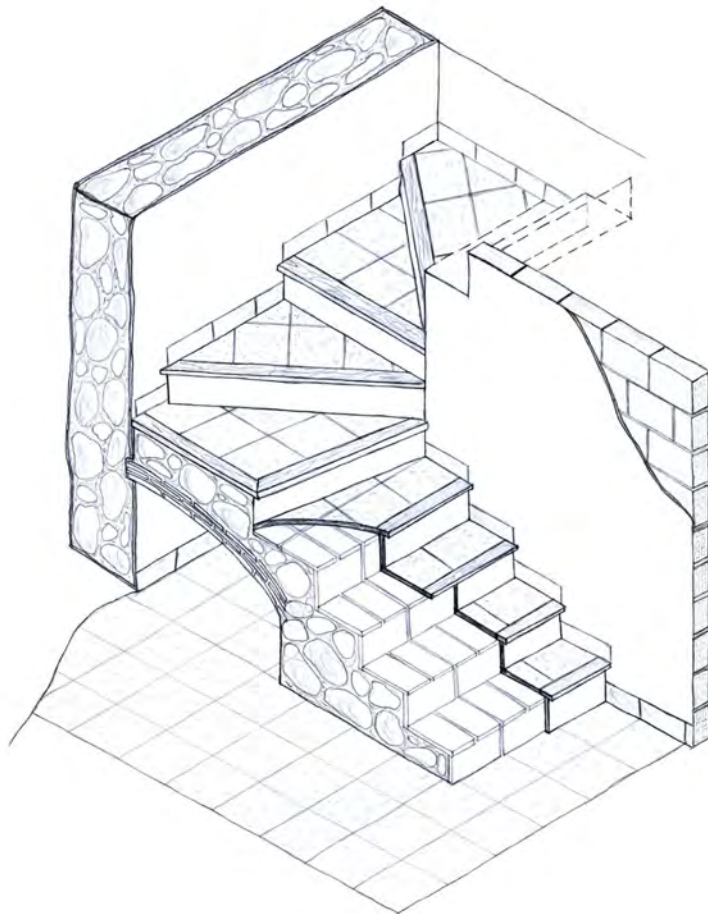

1st construction detail: door

Singulars elements

Chimneys

Chimneys consist of two parts: the fireplace where the heat for the building is produced, and the chimney shaft, the building element in which the smoke of the fireplace is canalized to the outside.

The central hearth is found in the oldest houses but actually it is found leaning against the wall, even creating a cavity on it to evacuate hearth fumes on the same vertical line and through a tronco-conical extractor hood to make the fume ascend directly along the shaft till the outside.

The extractor hood as well as the chimney shaft, both the internal and the external, are normally built with light and flat materials, slabs or bricks, taken with lime or gypsum mortar and supported by building resistant elements, floors and roof.

Chimney shafts are commonly prism-shaped, which is typical of fireplaces placed in some side part of the floor, and can arise next to the party wall, in the middle of the slope and even next to the eave edge. Because its size, slender and variety, overall in its upper end, it is one of the elements which always has distinguished the diversity of traditional construction.

Wall cavities normally were implemented with reference to the builder's experience, i.e. without technical studies on the transmission of stress or load capacity. These cavities, usually on the ground or first floors, not only were used to put up the fireplace, whose structural solution usually was solved in an arch or semi-vault form, but also was used to accommodate shelves or cupboards whose structural solution is often given by a lintel to distribute the stress.

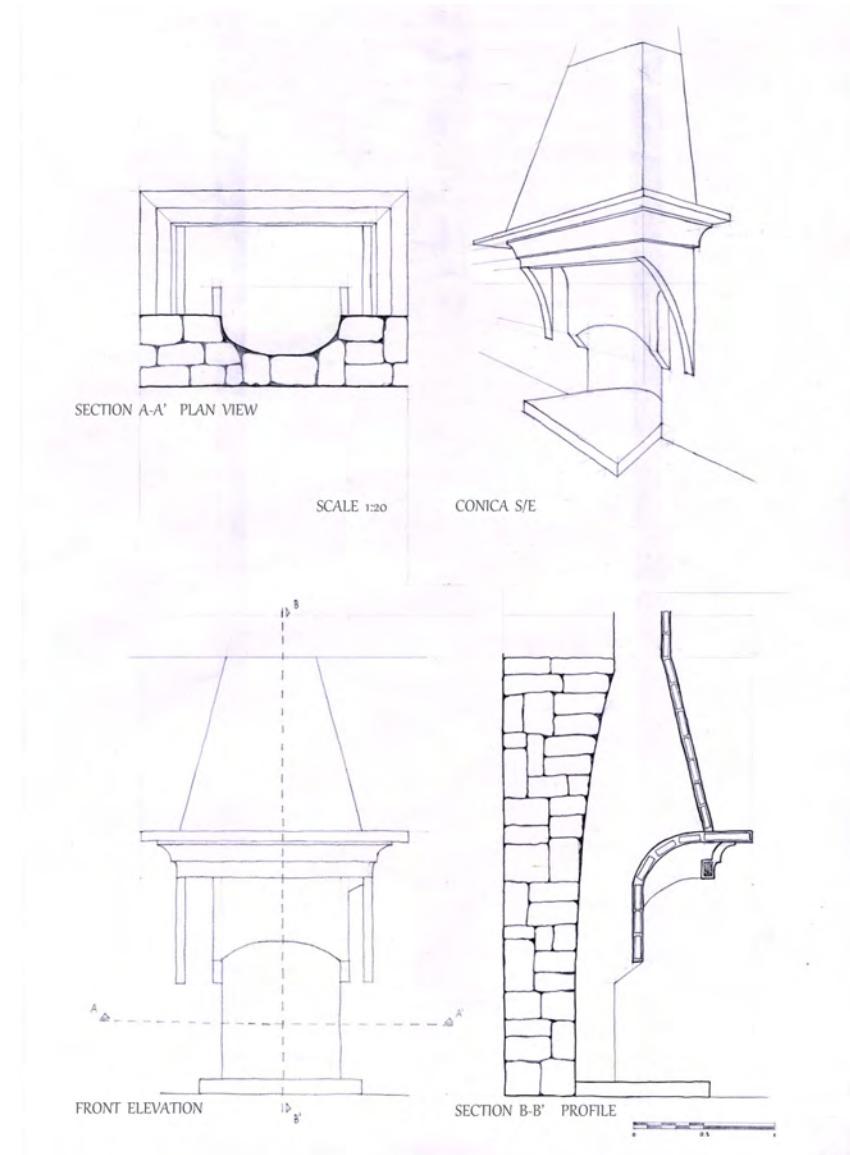

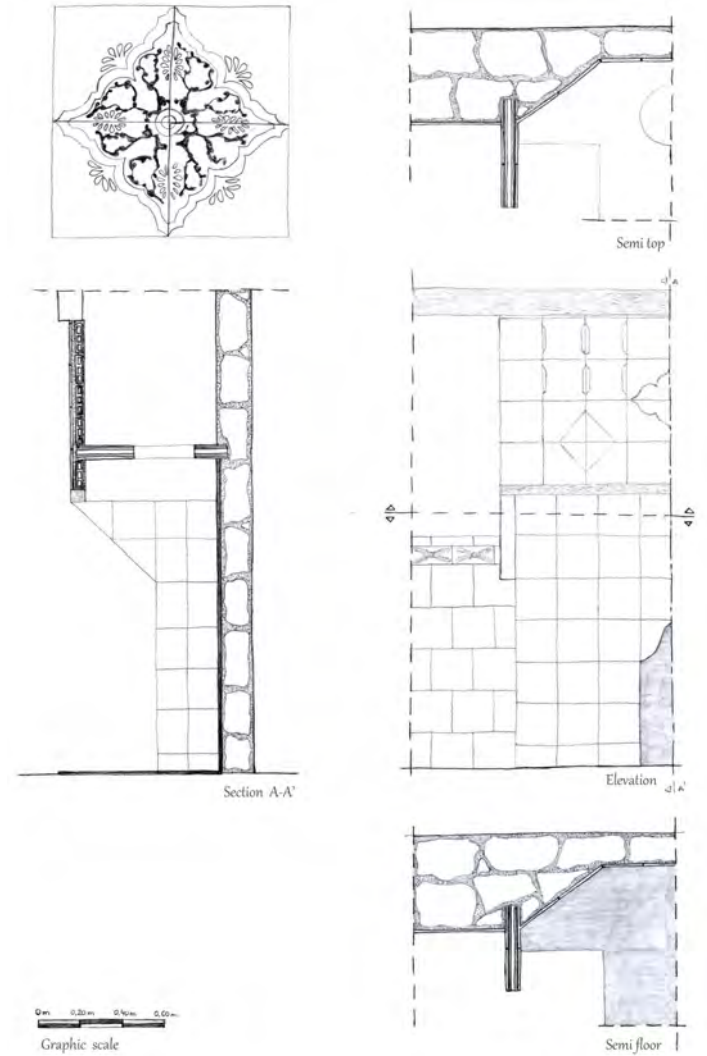
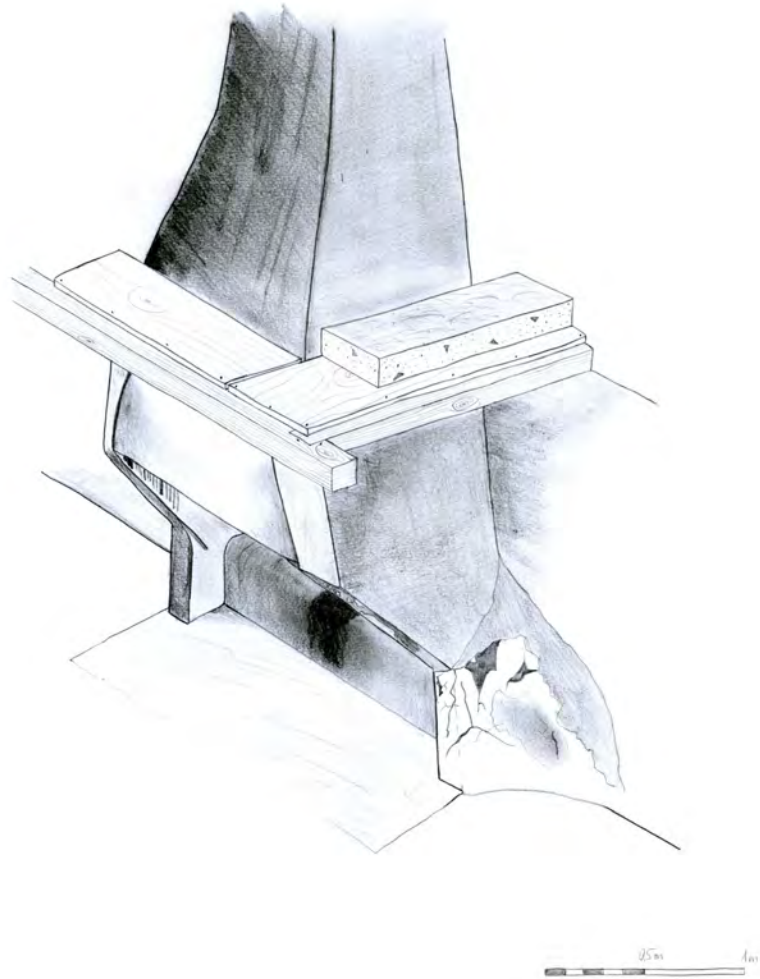

Bibliography

- BIARGE, F., BIARGE, A. (Ed.) 2001. *Casa por casa. Detalles de arquitectura rural pirenaica*. Huesca.
- FONT, F., HIDALGO, P., 2009. *Arquitecturas de tapia*. Castellón. COAAT.
- HEYMAN, J. 1995. *Teoría, historia y restauración de estructuras de fábrica*. Madrid. ETSAM. Instituto Juan de Herrera.
- HEYMAN, J. 1999. *El esqueleto de piedra. Mecánica de la arquitectura de fábrica*. Madrid. ETSAM. Instituto Juan de Herrera.
- HUERTA, S. 2004. *Arcos, bóvedas y cúpulas. Geometría y equilibrio en el cálculo tradicional de estructuras de fábrica*. Madrid. ETSAM. Instituto Juan de Herrera.
- NOURISSIER, G. et al. 2002. *Arquitectura tradicional mediterránea*. Avignon. Ecole d'Avignon.
- REGALADO, F. 1999. *Los forjados de los edificios: pasado, presente y futuro*. Alicante. CYPE Ingenieros.
- RODRÍGUEZ ORTÍZ, J. M. et al. 1996. *Curso aplicado de cimentaciones*. Madrid. COAM.
- TRUÑO, Á. 2004. *Construcción de bóvedas tabicadas*. Madrid. ETSAM. Instituto Juan de Herrera.

Authors of the drawings

Foundations

David Moreno Estupiña	2008/2009
Lucía Cabedo Vicente	2008/2009
Rubén Senar Lluch	2009/2010

Walls. Stresses

Walls Stonework

Carlos Sánchez Trujillo	2009/2010
Ivan Tárrega Saura	2008/2009
Fernando Gargallo Salvador	2008/2009

Walls. Masonry

Alba Bermejo Sancho	2008/2009
Berta Llop Sebastiá	2010/2011
Paula Pérez García	2008/2009

Walls. Ashlar Masonry

David Santos Mahillo	2009/2010
Juan Torres Bueno	2010/2011
Albert Piñas Font	2008/2009

Walls. Sun-dried bricks and industrialized bricks

Sergio Rodríguez Ariño	2008/2009
Ana Salvador Vives	2008/2009
David Ruíz Ferré	2008/2009

Walls. Rammed earth

Openings. Windows

Pedro Ventura Henares	2009/2010
Alejandra Miguel Escrig	2010/2011
Gustavo García Ribera	2009/2010

Openings. Doors

Rubén Bel Traver	2009/2010
Paula López Burdeos	2008/2009
Bárbara Álvarez Vazquez	2009/2010

Openings. Balconies

Andrés Felius Albalat	2009/2010
Nerea Tena Escrig	2010/2011
Daniel Orts Moya	2010/2011

Stonework arches & vaults. Arches

Josep Casanova Villalonga	2009/2010
Lucía Cabedo Vicente	2008/2009
Borja Ferrandis Franch	2009/2010

Stonework arches & vaults. Vaults

Julián Rodríguez Comins	2008/2009
José Miguel Olea Catalán	2008/2009
Ferran Escalada Beltrán	2008/2009

Bricked-up arches & vaults. Thrusts & counteracts

Bricked-up arches & vaults. Arches

Félix Martínez Nadal	2008/2009
Sheila Irene Parreño	2008/2009
Pedro Vinagre Fernández	2009/2010

Bricked-up arches & vaults. Vaults

Lorena Edo Rull	2008/2009
-----------------	-----------

Bricked-up arches & vaults. Jack vault

Rubén Senar Lluch	2009/2010
Lorena Edo Rull	2008/2009
Vanesa Edo Escrig.	2010/2011

Bricked-up arches & vaults. Stair vaults

Sergio Rodríguez Ariño	2008/2009
Sheila Irene Parreño	2008/2009
Pedro Vinagre Fernández	2009/2010
Cristian Miravet Aibar	2010/2011
Daniel Orts Moya	2010/2011

Bricked-up arches & vaults. Domes

David Moreno Estupiña	2008/2009
-----------------------	-----------

Wooden frameworks. Floors

Juan Carlos Sáez Ibáñez	2009/2010
Sergio Traver Monterroso	2010/2011
Alexis Chumillas Mateu	2010/2011

Wooden frameworks. Stairs

Isidro Sánchez Heras	2010/2011
Joaquín Aleixandre Albiol	2010/2011
David Santos Mahillo	2010/2011

Wooden frameworks. Roofs and Slopes

Emilio Fuentes García	2008/2009
Josep Casanova Villalonga	2009/2010
Diego J. Basco Clausell	2010/2011

Wooden frameworks. Roofs – Eaves

Berta Llop Sebastià	2010/2011
Rubén Bel Traver	2009/2010
Juan Torres Bueno	2010/2011

Covering

Pedro Vinagre Fernández	2009/2010
David Moreno Estupiña	2008/2009
Joaquín Marco Pastor	2008/2009

Vertical Coatings

Manuel Cano Gómez	2008/2009
Bárbara Álvarez Vazquez	2010/2011
María Orenge Izquierdo	2010/2011

Horizontal Coatings

Miguel Martí González	2010/2011
Susana Aparicio Lara	2010/2011
Alberto García Ortega	2009/2010

Singular elements. Chimneys

Ramón Casas Manteiga	2009/2010
Joaquín Aleixandre Albiol	2010/2011
Vanesa Edo Escrig	2010/2011